

Lateral Spring Plungers

22140.0414



Product Description

To be used for positioning and applying pressure, e.g. during painting and sandblasting.

Material

Ball

- Ball-bearing steel, hardened

Body

- Free cutting steel, blackened

Spring

- Plastic (PU)

Assembly

Insertion bore l_3 to be considered.

More information

Notes

Special types on request.

Drawing

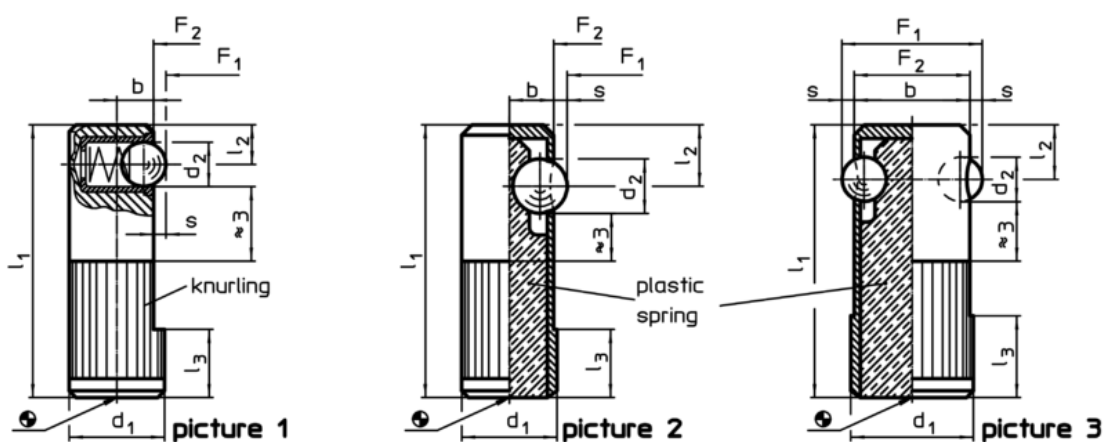

Order information

Dimensions						Location hole H8	Stroke s	Spring load ¹⁾		Temperature		Weight	Art. No.
d ₁ +0,1	d ₂	l ₁	l ₂	l ₃	b			F ₁	F ₂	min.	max.		
[mm]						[mm]	[mm]	[N]	[°C]				
ball from ball-bearing steel, heavy spring load, one-sided – picture 2													
14	8	40	9	10	6,5	14	2	120	480	-40	80	20	22140.0414

¹⁾ statistical average value

Application example

