

Lateral Spring Plungers

22140.0412



Product Description

To be used for positioning and applying pressure, e.g. during painting and sandblasting.

Material

- Ball**
 - Ball-bearing steel, hardened
- Body**
 - Free cutting steel, blackened
- Spring**
 - Plastic (PU)

Assembly

Insertion bore l_3 to be considered.

More information

Notes

Special types on request.

Drawing

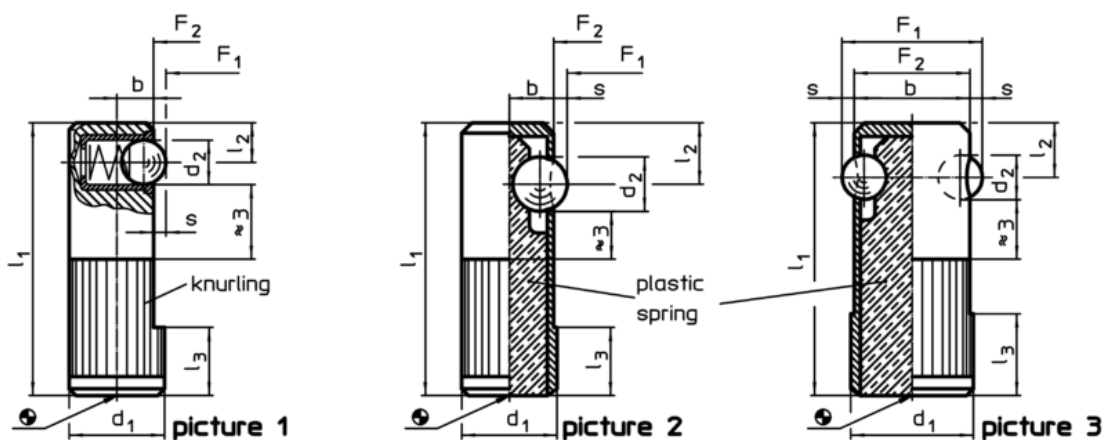

Order information

Dimensions						Location hole H8	Stroke s	Spring load ¹⁾		Temperature		Weight [g]	Art. No.
d_1 +0,1	d_2	l_1	l_2	l_3	b			F_1 ~	F_2 ~	min.	max.		
[mm]						[mm]	[mm]	[N]		[°C]		[g]	
ball from ball-bearing steel, heavy spring load, one-sided – picture 2													
12	6,5	35	8	9	5,5	12	1,5	80	260	-40	80	14	22140.0412

¹⁾ statistical average value

Application example

