

Lateral Spring Plungers

22140.0410



Product Description

To be used for positioning and applying pressure, e.g. during painting and sandblasting.

Material

Ball

- Ball-bearing steel, hardened

Body

- Free cutting steel, blackened

Spring

- Plastic (PU)

Assembly

Insertion bore l_3 to be considered.

More information

Notes

Special types on request.

Drawing

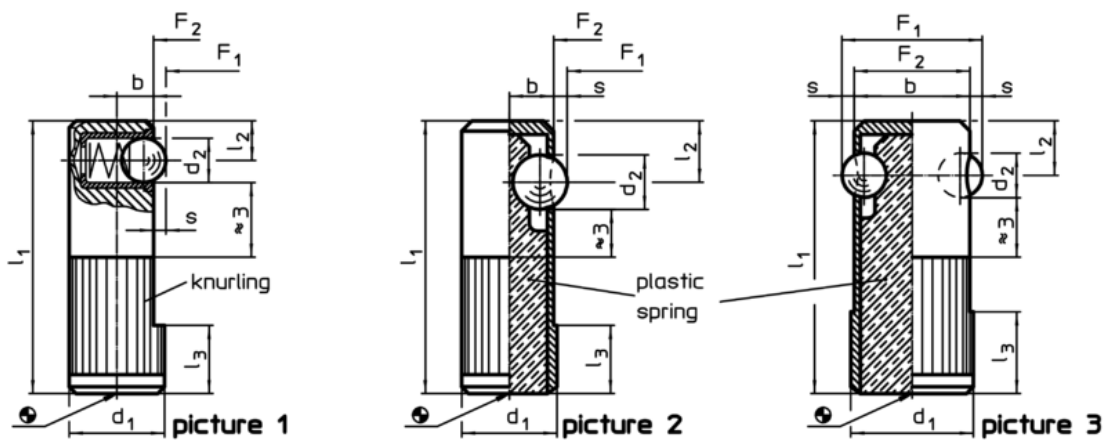

Order information

Dimensions						Location hole H8 [mm]	Stroke s [mm]	Spring load ¹⁾		Temperature		Weight [g]	Art. No.
d_1 +0,1	d_2	l_1	l_2	l_3	b			F_1 ~ [N]	F_2 ~ [N]	min.	max.		
ball from ball-bearing steel, heavy spring load, one-sided – picture 2													
10	5,5	30	7	8	4,5	10	1	60	170	-40	80	9	22140.0410

¹⁾ statistical average value

Application example

