

Lateral Spring Plungers

22140.0112



Product Description

To be used for positioning and applying pressure, e.g. during painting and sandblasting.

Material

Ball

- Thermoplastic POM, white

Body

- Free cutting steel, blackened

Spring

- Stainless steel

Assembly

Insertion bore l_3 to be considered.

More information

Notes

Special types on request.

Drawing

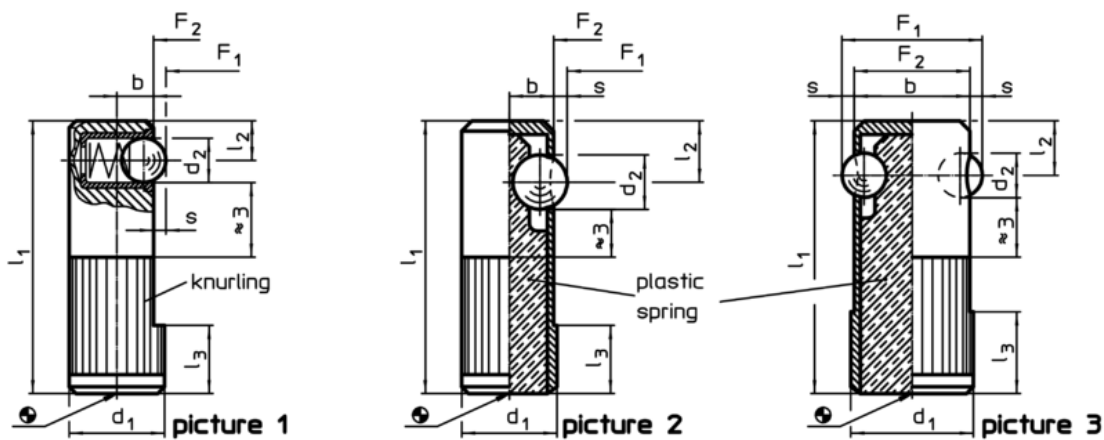

Order information

Dimensions							Location hole H8	Stroke s	Spring load ¹⁾		Temperature		Weight [g]	Art. No.
d_1 +0,1	d_2	l_1	l_2	l_3	b	F_1			F_2	min.	max.	[°C]		
[mm]							[mm]	[mm]	[N]				[g]	
ball from thermoplastic, standard spring load, one-sided – picture 1														
12	5	35	4,8	9	5	12	1,6	6,5	13	-30	50	28	22140.0112	

¹⁾ statistical average value

Application example

