

Lateral Spring Plungers

22140.0110



Product Description

To be used for positioning and applying pressure, e.g. during painting and sandblasting.

Material

Ball

- Thermoplastic POM, white

Body

- Free cutting steel, blackened

Spring

- Stainless steel

Assembly

Insertion bore l_3 to be considered.

More information

Notes

Special types on request.

Drawing

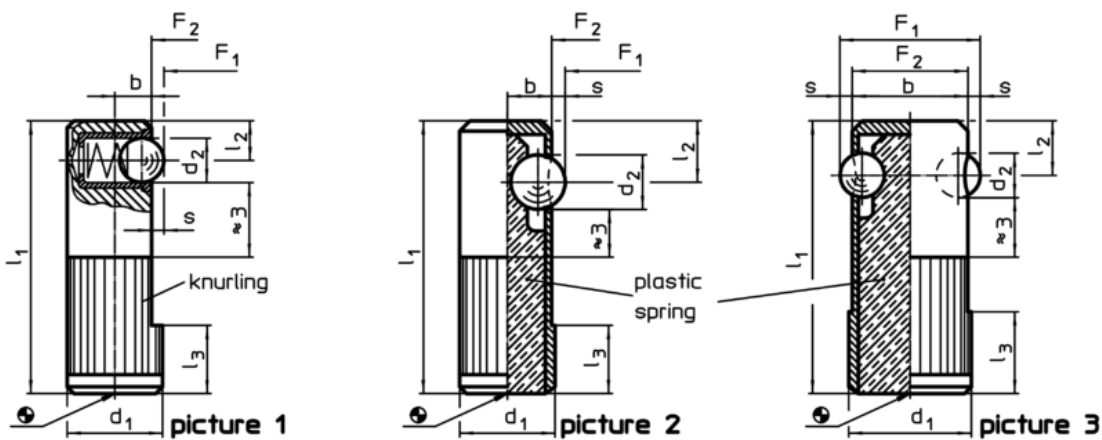

Order information

Dimensions						Location hole H8	Stroke s	Spring load ¹⁾		min.	max.	[g]	Art. No.
d_1 +0,1	d_2	l_1	l_2	l_3	b			F_1 ~	F_2 ~				
ball from thermoplastic, standard spring load, one-sided – picture 1													
10	4	30	4,2	7	4	10	1	4,5	9	-30	50	17	22140.0110

¹⁾ statistical average value

Application example

