

Lateral Spring Plungers

22140.0108



Product Description

To be used for positioning and applying pressure, e.g. during painting and sandblasting.

Material

Ball

- Thermoplastic POM, white

Body

- Free cutting steel, blackened

Spring

- Stainless steel

Assembly

Insertion bore l_3 to be considered.

More information

Notes

Special types on request.

Drawing

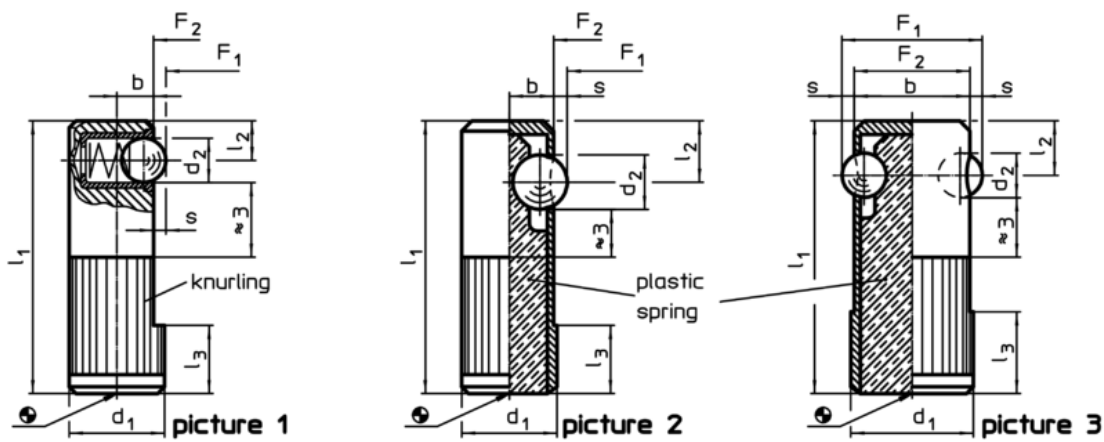

Order information

Dimensions						Location hole H8	Stroke s	Spring load ¹⁾		Temperature		Weight [g]	Art. No.
d_1 +0,1	d_2	l_1	l_2	l_3	b			F_1 ~	F_2 ~	min.	max.		
[mm]						[mm]	[mm]	[N]		[°C]		[g]	
ball from thermoplastic, standard spring load, one-sided – picture 1													
8	3	25	3,6	6	3,2	8	0,8	2,5	6,5	-30	50	9	22140.0108

¹⁾ statistical average value

Application example

