

Lateral Spring Plungers

22140.0012



Product Description

To be used for positioning and applying pressure, e.g. during painting and sandblasting.

Material

Ball

- Stainless steel, hardened

Body

- Free cutting steel, blackened

Spring

- Stainless steel

Assembly

Insertion bore l_3 to be considered.

More information

Notes

Special types on request.

Drawing

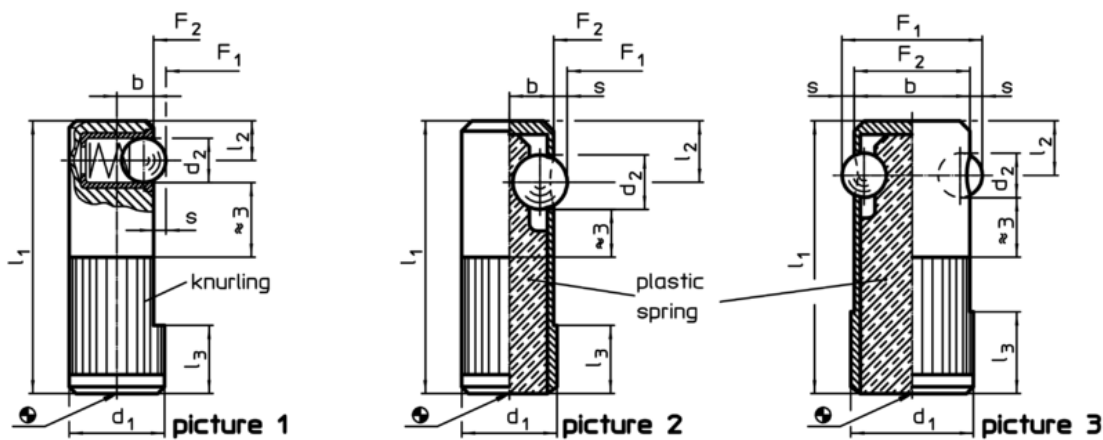

Order information

Dimensions						Location hole H8 [mm]	Stroke s [mm]	Spring load ¹⁾ [N]		Temperature [°C]		Weight [g]	Art. No.
d_1 +0,1	d_2	l_1	l_2	l_3	b			F_1	F_2	min.	max.		
ball from stainless steel, standard spring load, one-sided – picture 1													
12	5	35	4,8	9	5	12	1,6	6,5	13	-30	50	29	22140.0012

¹⁾ statistical average value

Application example

