

Lateral Spring Plungers

22140.0008



Product Description

To be used for positioning and applying pressure, e.g. during painting and sandblasting.

Material

Ball

- Stainless steel, hardened

Body

- Free cutting steel, blackened

Spring

- Stainless steel

Assembly

Insertion bore l_3 to be considered.

More information

Notes

Special types on request.

Drawing

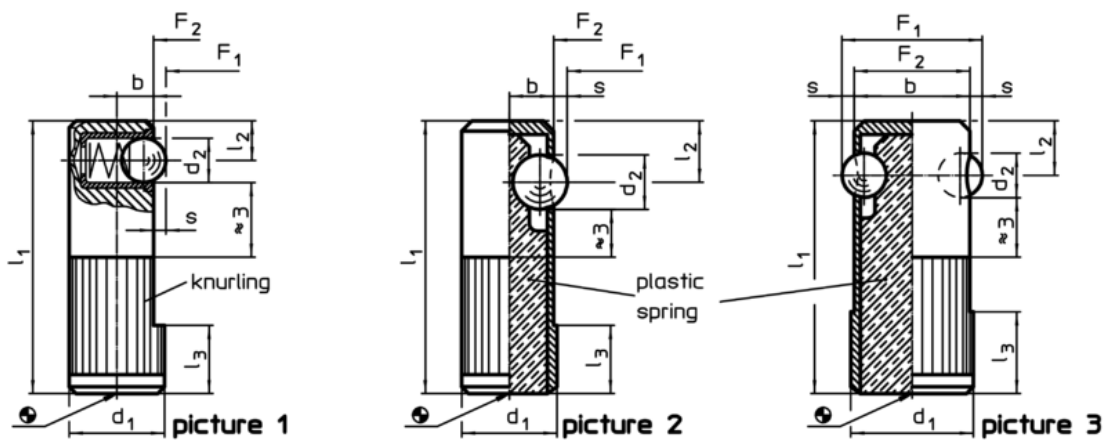

Order information

Dimensions						Location hole H8 [mm]	Stroke s [mm]	Spring load ¹⁾		Temperature		Weight [g]	Art. No.
d ₁ +0,1	d ₂	l ₁	l ₂	l ₃	b			F ₁ ~	F ₂ ~	min.	max.		
ball from stainless steel, standard spring load, one-sided – picture 1													
8	3	25	3,6	6	3,2	8	0,8	2,5	6,5	-30	50	9	22140.0008

¹⁾ statistical average value

Application example

