

Mounting Blocks for index bolts and index plungers

22120.0348

Product Description

Assembly support and extended applications for index bolts.
Also usable for index plungers size 6, 8 and 10.

Material

Threaded Pin

- Steel, blackened, with brass pad

Body

- Steel, blackened



Drawing

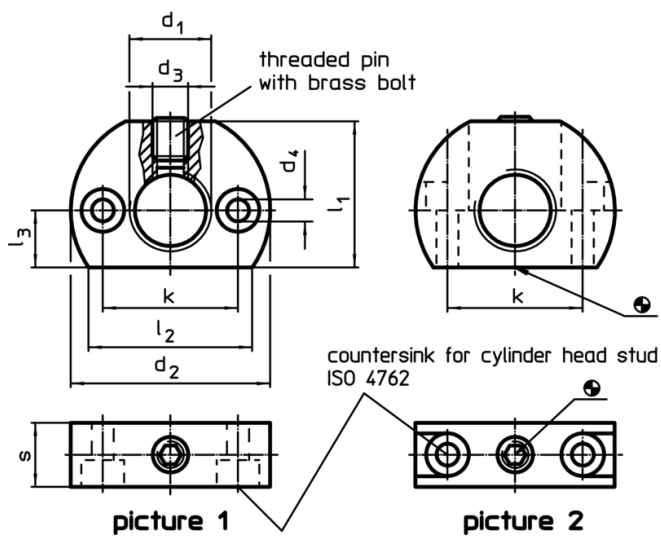

Order information

Dimensions									max. [°C]	[g]	Art. No.	
d ₁	d ₂	d ₃	d ₄	k ±0,1	l ₁	l ₂ ~	l ₃	s				
mounting hole vertical to index bolt and index plunger – picture 2, Steel												
M16 x 1,5	46	M8	5,5	32	33	38	13	15	250	106	22120.0348	

Application example

