

## Index Bolts 22120.0319



### Product Description

Index bolts are used for indexing purposes.  
Plastic cover for grip allows better handling.

### Material

#### Body

- Free cutting steel, blackened

#### Locking pin

- Steel, hardened

#### Catch

- Free cutting steel, blackened

### Operation

By turning the index bolt 180° the locking pin will be pulled-in and secured by a notched catch (when locking pin must not project).

### More information

### Notes

Lock nuts have to be purchased separately.

### Further products

- Mounting Blocks, for index plungers and index bolts zinc die-cast
- Locating Bushings, for index bolts and index plungers
- Mounting Blocks, for index bolts and index plungers

### Drawing

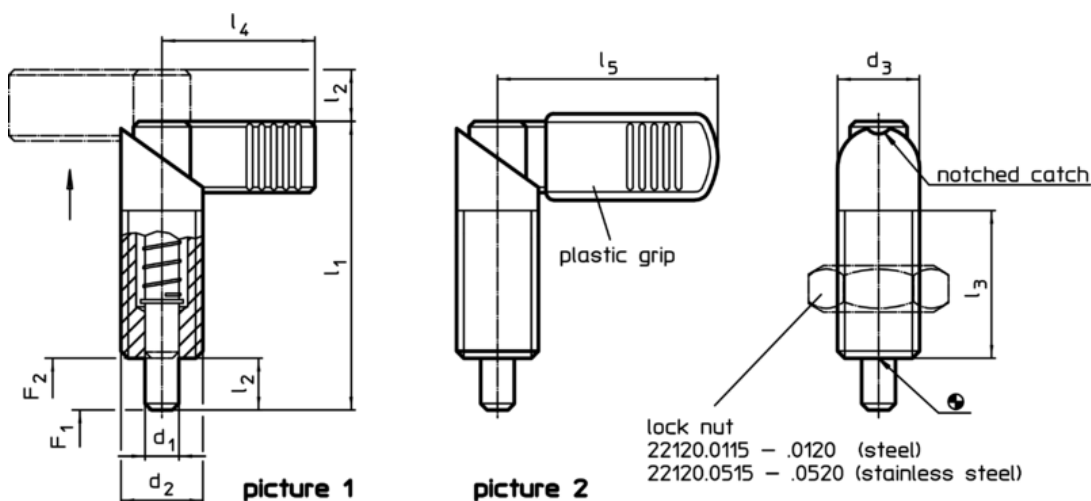



### Order information

Dimensions							Spring load <sup>1)</sup>		max.		Art. No.
d <sub>1</sub>	d <sub>2</sub>	d <sub>3</sub>	l <sub>1</sub>	l <sub>2</sub>	l <sub>3</sub>	l <sub>4</sub>	F <sub>1</sub>	F <sub>2</sub>			
-0,02							~	~			
-0,04											
[mm]							[N]		[°C]	[g]	
without plastic cover for grip – picture 1, Free cutting steel											
10	M16 x 1,5	16	56	10	30	32	11,5	30,5	250	64	22120.0319

<sup>1)</sup> statistical average value

Accessories

	Dimensions $d_2$ [mm]	WS [mm]	 [g]	Art. No.
lock nuts ISO 8675 (DIN 439) for the following sizes, Steel				
	M16 x 1,5	24	18,0	<a href="#">22120.0118</a>