

Mounting Blocks for index plungers and index bolts zinc die-cast

22110.0410

Product Description



Assembly support and extended applications for index bolts and index plungers. Also to be used as a seat for locating bushings EH 22110.

Material

Threaded Pin

- Steel, blackened, with brass pad

Body

- Zinc die-cast, plastic coated, black

Assembly

Index plunger must be assembled in hole d_1 on countersink side.

Drawing

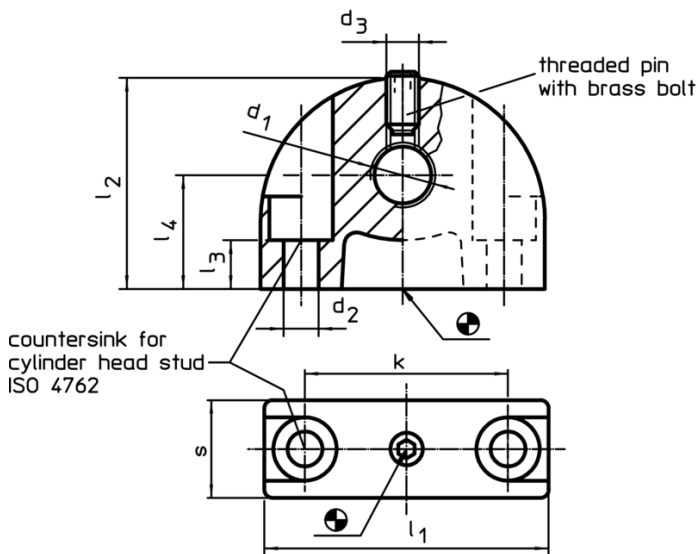

Order information

Dimensions											max. [°C]	[g]	Art. No.		
d_1	d_2	d_3	d_4	k	l_1	l_2	l_3 -0,2	l_4	s	t					
mounting hole vertical to index bolt and index plunger															
M10 x 1	4,3	M4	10,2	25	35	26	11,5	14	12	2	100	36	22110.0410		

Application example

