

Index Plungers· with mounting flange, horizontal

22110.0328



Product Description

Index plungers are used for indexing bores.

Material

Housing

- Zinc die-cast, plastic coated, black

Locking pin

- Stainless steel 1.4305

Knob

- Thermoplastic PA 6, black, dull

Assembly

Assembly by means of washers ISO 7092.

Operation

When using locking index plungers, the knob is pulled-out, turned 90° and secured by a notched catch (when locking pin must not project).

More information

Notes

Knob not removable.

Drawing

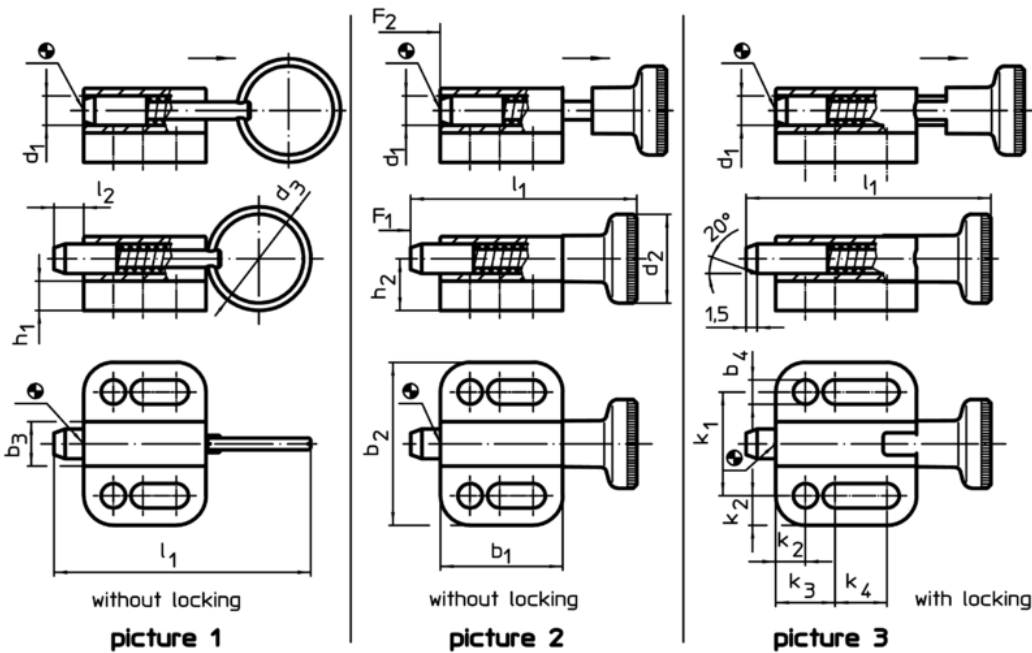

Order information

Dimensions														Spring load ¹⁾		Temperature		Weight [g]	Art. No.
d_1	d_2	b_1	b_2	b_3	b_4	h_1	h_2	k_1	k_2	k_3	k_4	l_1	l_2	F_1	F_2	min.	max.		
[mm]														~	~	[°C]		[g]	
with knob, without locking – picture 2																			
8	21	33	34	12	5,4	6	12,5	23	5,5	12	15,5	59	8	6	22	-30	80	59	22110.0328

¹⁾ statistical average value

Application example

