

## Index Plungers· with mounting flange, horizontal

22110.0325



### Product Description

Index plungers are used for indexing bores.

#### Material

##### Housing

- Zinc die-cast, plastic coated, black

##### Locking pin

- Stainless steel 1.4305

##### Knob

- Thermoplastic PA 6, black, dull

#### Assembly

Assembly by means of washers ISO 7092.

#### Operation

When using locking index plungers, the knob is pulled-out, turned 90° and secured by a notched catch (when locking pin must not project).

#### More information

#### Notes

Knob not removable.

### Drawing

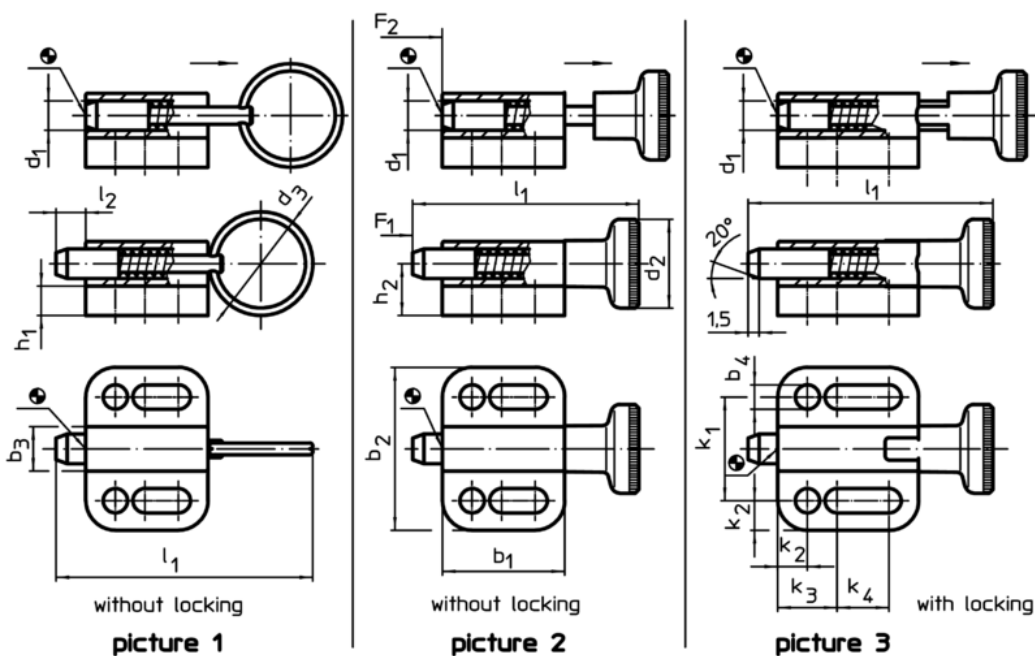

### Order information

Dimensions														Spring load <sup>1)</sup>		Temperature		Weight [g]	Art. No.						
d <sub>1</sub>	d <sub>2</sub>	b <sub>1</sub>	b <sub>2</sub>	b <sub>3</sub>	b <sub>4</sub>	h <sub>1</sub>	h <sub>2</sub>	k <sub>1</sub>	k <sub>2</sub>	k <sub>3</sub>	k <sub>4</sub>	l <sub>1</sub>	l <sub>2</sub>	F <sub>1</sub>	F <sub>2</sub>	min.	max.								
h9					-0,2			±0,05					min.	~	~	[°C]	[°C]	[g]							
[mm]																				[N]		[°C]		[g]	
<b>with knob, without locking – picture 2</b>																									
5	16	22	28	8	4,3	4,5	9,5	18	5	10	7	40	5	5	24	-30	80	20	22110.0325						

<sup>1)</sup> statistical average value

Application example

