

Index Plungers· with mounting flange, horizontal

22110.0306



Product Description

Index plungers are used for indexing bores.

Material

Housing

- Zinc die-cast, plastic coated, black

Locking pin

- Stainless steel 1.4305

Pull-ring

- Stainless steel 1.4310

Assembly

Assembly by means of washers ISO 7092.

Operation

When using locking index plungers, the knob is pulled-out, turned 90° and secured by a notched catch (when locking pin must not project).

More information

Notes

Knob not removable.

Drawing

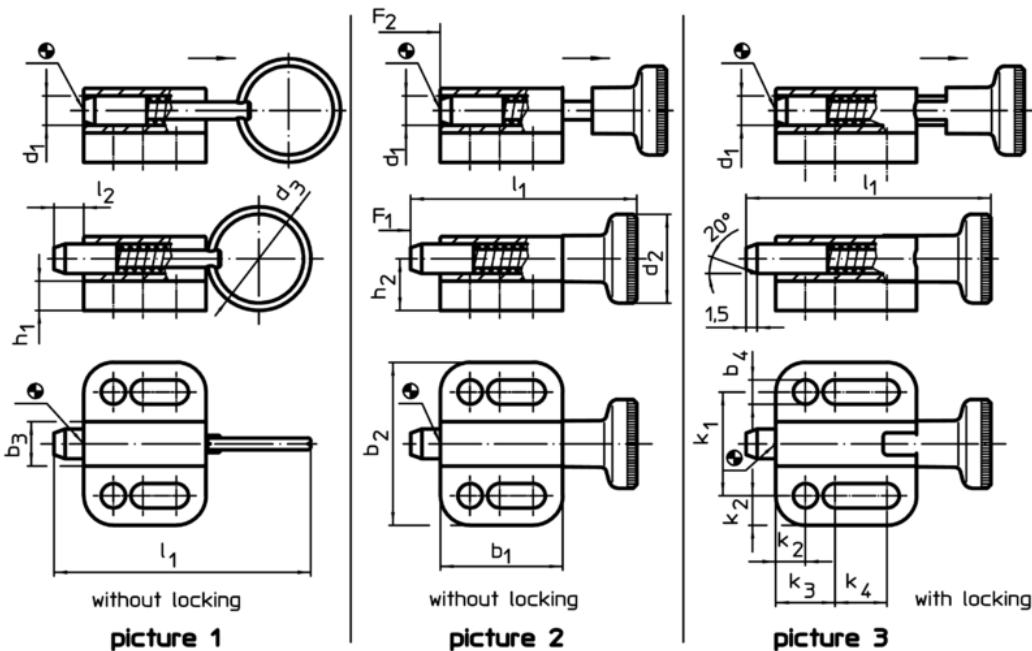

Order information

Dimensions														Spring load ¹⁾		max.		Art. No.	
d_1	d_3	b_1	b_2	b_3	b_4	h_1	h_2	k_1	k_2	k_3	k_4	l_1	l_2	F_1	F_2				
h9					-0,2			$\pm 0,05$					min.	~	~				
[mm]														[N]	[°C]	[g]			
with pull-ring, without locking – picture 1																			
6	24	27,5	32	10	5,4	5	10,5	21	5,5	12	10	57,5	6	5	21	100	40	22110.0306	

¹⁾ statistical average value

Application example

