

Index Plungers mini indexes

22110.0036



Product Description

Particularly suitable for screwing into thin walled pieces.
Performance in the smallest space requirements.

Material

Body

- Steel, zinc-plated by galvanization

Locking pin

- Stainless steel 1.4305

Knob

- Thermoplastic PA 6, black, dull

Assembly

Screw in the mini index. By lifting the knob, the hexagon will be released for assembly.
The screw length can be adapted by distance collars for index plungers (EH 22120.).

Operation

When using the self-locking type the knob is pulled-out, turned 30° and secured by a notched catch.

More information

Notes

Knob not removable.

Further products

- Distance Collars, for index plungers

Drawing

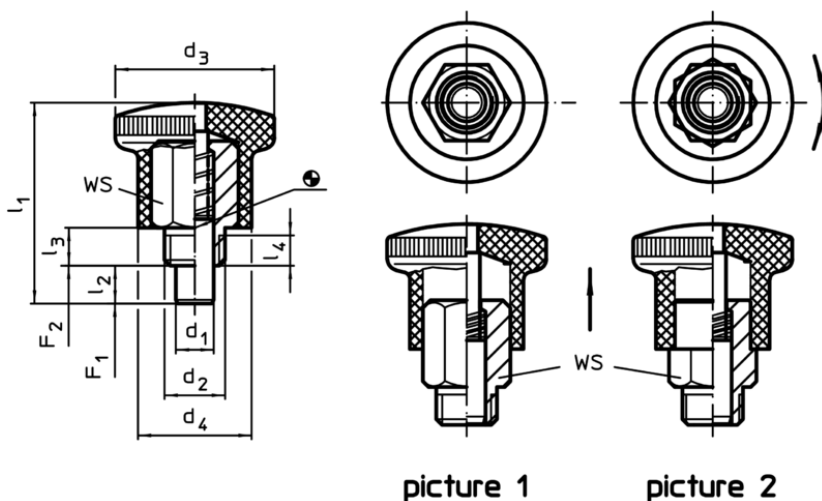

picture 1

picture 2

Order information

| Dimensions | | | | | | | | WS | Spring load ¹⁾ | | Temperature | | Weight | Art. No. |
|--|----------------|----------------|----------------|----------------|------------------------|----------------|------------------------|-----|---------------------------|----------------|-------------|------|--------|------------|
| d ₁ | d ₂ | d ₃ | d ₄ | l ₁ | l ₂ min. | l ₃ | l ₄ min. | | F ₁ | F ₂ | min. | max. | | |
| 0 -0,06 | | | [mm] | | | | | [N] | [N] | [°C] | | | | |
| with locking – picture 2, Steel | | | | | | | | | | | | | | |
| 5 | M8 x 0,75 | 21 | 15 | 26,5 | 5 | 5 | 3,5 | 10 | 4,5 | 12 | -30 | 80 | 14 | 22110.0036 |

¹⁾ statistical average value

Application example

