

Spring Plungers· smooth, long, with collar and ball 22080.1106



Product Description

Spring plungers can be used for locating or for applying pressure, as a detent or for ejection. This version has higher spring forces than the standard version. "EH 22080. Spring Plungers, smooth, with collar and ball".

Material

Body

- Stainless steel 1.4303

Ball

- Stainless steel, hardened

Spring

- Stainless steel

More information

Notes

Special types on request.
Spring range and forces are precisely tested.

References

Calculation of indexing resistance, see details at the start of the section.

Further products

- Spring Plungers, smooth, with collar and ball

Drawing

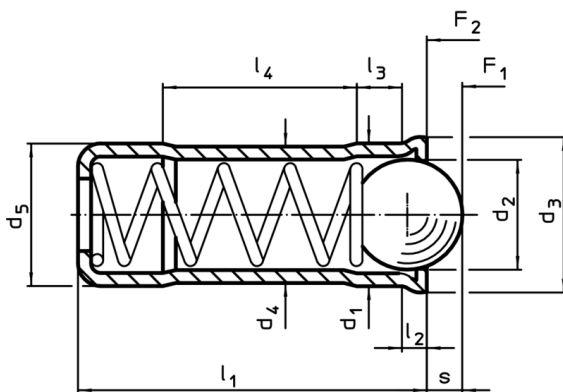

Order information

Dimensions										Stroke s +0,2 -0,1 [mm]	Spring load ¹⁾		max. [°C]	Location hole H7 [mm]	[g]	Art. No.
d_1 +0,1 +0,04	d_2	d_3	d_4	d_5 $\pm 0,04$	l_1	l_2 ~	l_3 ~	l_4 ~	F_1 ~		F_2 ~	[N]				
6	5	6,5	5,85	6	15	1	2,3	8,2	28	47,5	250	6	2	22080.1106		

¹⁾ statistical average value

Application example

