

Spring Plungers· smooth, with collar and ball
22080.1006



Product Description

Spring plungers can be used for locating or for applying pressure, as a detent or for ejection.

Material

Body

- Stainless steel 1.4303

Ball

- Stainless steel, hardened

Spring

- Stainless steel

Assembly

A tolerance of H7 is recommended for the locating hole of d_1 .

Characteristic

Light spring load: marked with one line

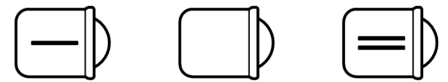

Light spring load

Standard spring load

Heavy spring load

More information

Notes

Special types on request.

Spring range and forces are precisely tested.

References

Calculation of indexing resistance, see details at the start of the section.

Version with higher spring forces see "EH 22080. Spring Plungers, smooth, long, with collar and ball".

Further products

- Spring Plungers, smooth, long, with collar and ball

Drawing

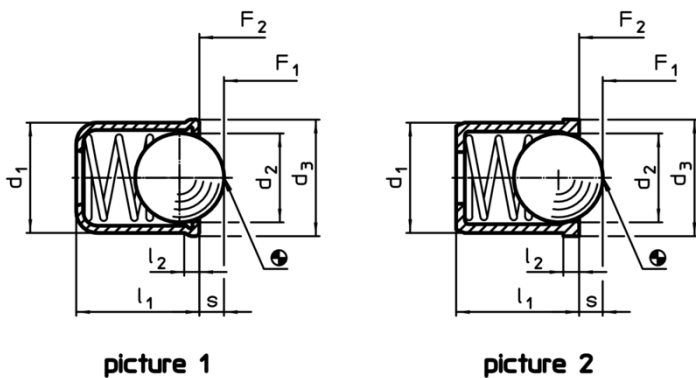

picture 1

picture 2

Order information

Dimensions					Stroke s [mm]	Spring load ¹⁾ [N]		max. [°C]	Location hole H7 [mm]	[g]	Art. No.
d ₁ +0,1	d ₂	d ₃	l ₁	l ₂		F ₁ ~	F ₂ ~				
body and ball from stainless steel, light spring load – picture 1											
6	5	6,5	7	1	1,8	2,3	6,5	250	6	1	22080.1006

¹⁾ statistical average value

Application example

