

Spring Plungers with moveable ball and slot 22051.0212



Product Description

Spring plungers can be used for locating or for applying pressure, as a detent or for ejection. The running of the ball minimises wear on the counterpart, this also results in a positive locking behaviour depending on the counterpart. Plastic balls offer electric insulation.

Material

- Body**
 - Free cutting steel, blackened
- Bearing**
 - Plastic
- Ball**
 - Ball-bearing steel, hardened
- Spring**
 - Stainless steel

Characteristic

Reinforced spring load: marked with two lines

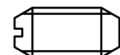

Standard spring load



Heavy spring load

More information

Notes

Special types on request.
Spring range and forces are precisely tested.

References

Thread lock on request, please refer to appendix - Technical Data - Calculation of indexing resistance, see details at the start of the section.

Drawing

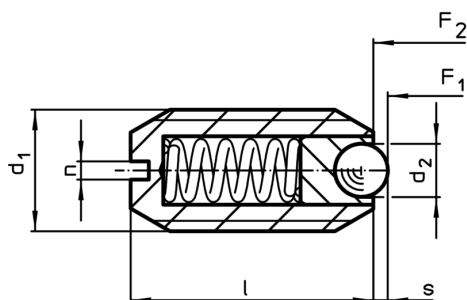

Order information

Dimensions				Stroke s [mm]	Spring load ¹⁾		Temperature		Weight [g]	Art. No.
d ₁	d ₂	l	n		F ₁ ~ [N]	F ₂ ~	min.	max.		
[mm]							[°C]			
free cutting steel, heavy spring load										
M12	6,5	22	2	2,3	39,5	77,3	-30	90	12,3	22051.0212

¹⁾ statistical average value

Application example

