

see us online at: www.acrotechinc.com



Proudly made
in the U.S.A



ACROTECH

Manufacturers of K-Prene®... the unequalled Urethane

Custom Urethane

Industrial Applications



Metal Forming Applications

Roll Bending Machines



Acrotech can cost effectively produce urethane parts in any volume you need. We can make parts that are sized under a cubic inch to over 400 pounds! We welcome you to check out all of our products and services in this catalog. In addition you can find us on the internet at www.acrotechinc.com for up to date pricing and further information.

Thank You,

Andy Oliver - President - Acrotech Inc.

- 30+ years of experience making urethane parts for a variety of industries
- Modern 33,000 sq. ft. manufacturing facility - **100% Made in the USA**
- Urethane casting or compression mold processes - providing cost effective solutions
- Standard products available along with industry specific custom parts made to your specs
- Custom molded urethane parts in any durometer or color
- Captive facility with in-house mold construction and secondary machining
- High volume production sheet metal roll bending machines

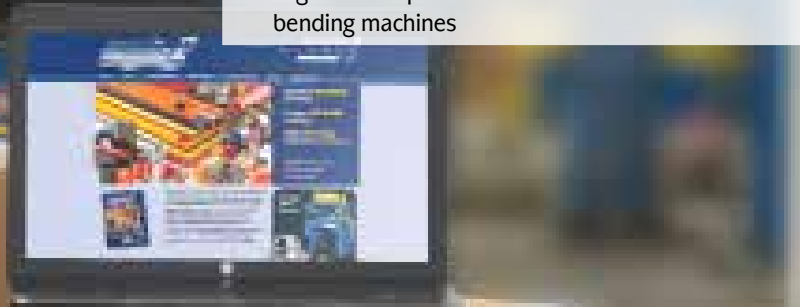

urethane products & services

Custom Urethane Molding:

Acrotech has been custom molding for decades. We are proudly the best in the business. No job is too small or too large. We successfully manage both high volume and individual orders.

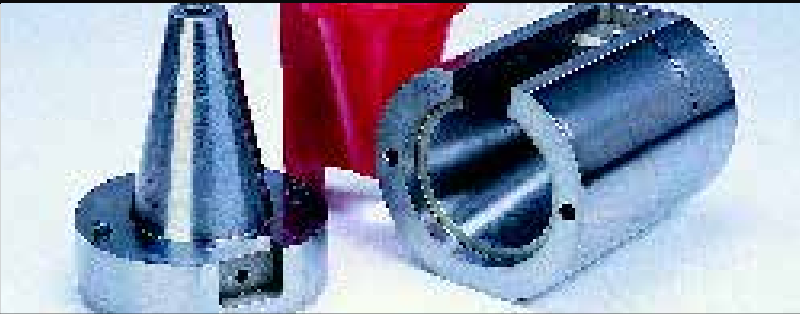

Reverse Engineering:

Often in industrial situations a part is needed for a project but the supply is gone or no longer produced. We are able to reverse engineer your part to fit and work just like it originally did resulting in a better end product.

Hand Batch / Small Quantity:

Our hands on approach allows us to get personal with all of our customers. We are flexible and cost effective at producing small volume runs. We take extra care to meet your needs.



Large Batch / Machine Pour:

Utilizing multiple processing machines we service numerous larger volume OEM customers. Maintaining low overhead Acrotech can pour what you need at a surprising cost savings over other suppliers.



Mold Machining - Inserts:

We design and machine all molds in-house. Experienced machinists operate multiple manual and CNC machining centers. This allows better quality control and reduced lead times to our customers.



Urethane - Inspection:

Every part that is molded and machined at Acrotech gets a part number as well as a final inspection. We go the extra mile to clean up the urethane prior to shipping for a flawless product every time.



Custom Durometers:

We have our standard durometers **Yellow 40A**, **Black 60A**, **Orange 80A**, **Blue 90A**, **Red 95A** and **Brown 75D** however we are able to pour urethane anywhere from **(10A to 85D)**.



Custom Colors:

Urethane can be molded in one of our **(20)** custom colors. Have a company color scheme? Product that needs to stand out? We can help make the color yours!



FDA Approved Urethane:

Approved urethane for use in the food service industry, under section #177.21000 subpart F. We can make hoppers, paddles, mixers, conveyor parts and more.



Shaft - Roller Recovery:

We are able to strip and recover a large variety of shafts. This includes multiple sizes, durometers, profiles and surface finishes. Parts can be refurbished at a fraction of the cost of OEM spare parts.



custom urethane..... p. 2-3

- Custom Molding p. 2
- Batch Pouring p. 2-3
- Machining p. 3
- Inspection p. 3
- Custom Durometers p. 3
- FDA Urethane p. 3
- Roller Recovery p. 3

urethane information..... p. 5-8

- Urethane vs. Rubber p. 5
- K-Prene® Durometers p. 6
- Durometer Scale p. 7
- Physical Properties p. 7
- Machining of Urethane p. 8

standard urethane..... p. 9-12

- Precision Cast Sheets p. 9
- Round Rods p. 10
- Square/Rectangles p. 11
- Tubes/Springs p. 12

industrial urethane..... p. 12-21

- Urethane Washers p. 12
- Roller Recovering p. 13
- Bumpers p. 14-15
- Versa Roll™ p. 16
- Urethane Balls p. 17
- Tape/Adhesive p. 18
- Woodworking p. 19-20
- Automotive p. 21

metalworking urethane..... p. 22-29

- Metal Forming p. 22
- Acro-Hyde™** p. 23
- Press Brake Dies p. 24
- Acroform™ Inserts p. 25
- Punch Strippers p. 26-27
- Tubes/Springs p. 28-29

sheet metal rolling machines..... p. 30-35

- About Two Roll Bending p. 30
- Model Lineup p. 31
- Available Options p. 32-33
- Specifications p. 34
- Restoration p. 35
- Custom Rolling p. 35

urethane compared to natural and synthetic rubbers

Urethane produced parts will in most cases outperform natural and synthetic rubbers. The composition and materials of urethane are of higher grades and are able to withstand a much broader range of extreme properties. It is important to remember that urethane can be more expensive in material costs but less expensive to manufacture. Urethane will in most every case outlast natural and synthetic rubbers and that should be taken into consideration when purchasing high quality urethane products and K-Prene® from Acrotech Inc.

Please view the chart below to compare just how well urethane stands alone from natural and synthetic rubbers.

PROPERTIES	NATURAL RUBBER	SBR or BUNA S <small>butadiene styrene</small>	BUTYL <small>isobutylene isoprene</small>	NITRILE (BUNA N) <small>butadiene acrylonitrile</small>	NEOPRENE <small>chloroprene</small>	URETHANE
Tensile Strength, (PSI) Pure Gum	Over 3000	Below 1000	Over 1500	Below 1000	Over 3000	1000-10,000
Hardness Range (Durometer A)	30-90	40-90	40-75	40-95	40-95	33-95 + (75 Shore D)
Specific Gravity (base material)	0.93	0.94	0.92	1.00	1.23	1.10
Vulcanizing Properties	Excellent	Excellent	Good	Excellent	Excellent	Excellent
Adhesion to Metals	Excellent	Excellent	Good	Excellent	Excellent	Excellent
Adhesion to Fabrics	Excellent	Good	Good	Good	Excellent	Excellent
Tear Resistance	Good	Fair	Good	Fair	Good	Outstanding
Abrasion Resistance	Excellent	Good to Excellent	Good	Good	Excellent	Outstanding
Compression Set	Good	Good	Fair	Good	Fair to Good	Good
Compression Set Cold	Excellent	Good	Bad	Good	Very Good	Fair
Rebound Hot	Excellent	Good	Very Good	Good	Very Good	Good
Electric Strength	Excellent	Excellent	Excellent	Poor	Good	Excellent
Electrical Insulation	Good to Excellent	Good to Excellent	Good to Excellent	Poor	Fair to Good	Fair to Good
Permeability to Gases	Fair	Fair	Very Low	Fair	Low	Fair to Good
Acid Resistance: Dilute Concentrated	Fair to Good Fair to Good	Fair to Good Fair to Good	Excellent Excellent	Good Good	Excellent Good	Fair to Good Poor
Solvent Resistance:						
Aliphatic Hydrocarbons	Poor	Poor	Poor	Excellent	Good	Excellent
Aromatic Hydrocarbons	Poor	Poor	Poor	Good	Fair	Fair to Good
Oxygenated (ketones, etc.)	Good	Good	Good	Poor	Poor	Poor
Lacquer Solvents	Poor	Poor	Poor	Fair	Poor	Poor
Swelling in Lubricating Oil	Poor	Poor	Poor	Very Good	Good	Excellent
Oil and Gasoline	Poor	Poor	Poor	Excellent	Good	Excellent
Animal and vegetable Oils	Poor to Good	Poor to Good	Excellent	Excellent	Good	
Water Absorption	Very Good	Good to Excellent	Very Good	Fair to Good	Good	Good @ room temp. Poor @ 212°F.
Resistance to:						
Ozone	Fair	Fair	Excellent	Fair	Excellent	Outstanding
Sunlight Aging	Poor	Poor	Very Good	Poor	Very Good	Good
Heat Aging	Good	Very Good	Excellent	Excellent	Excellent	Good
Flame	Poor	Poor	Poor	Poor	Good	Fair
Heat	Good	Excellent	Excellent	Excellent	Excellent	Good
Cold	Excellent	Excellent	Good	Good	Good	Excellent
Oxidation	Good	Good	Excellent	Good	Excellent	Excellent

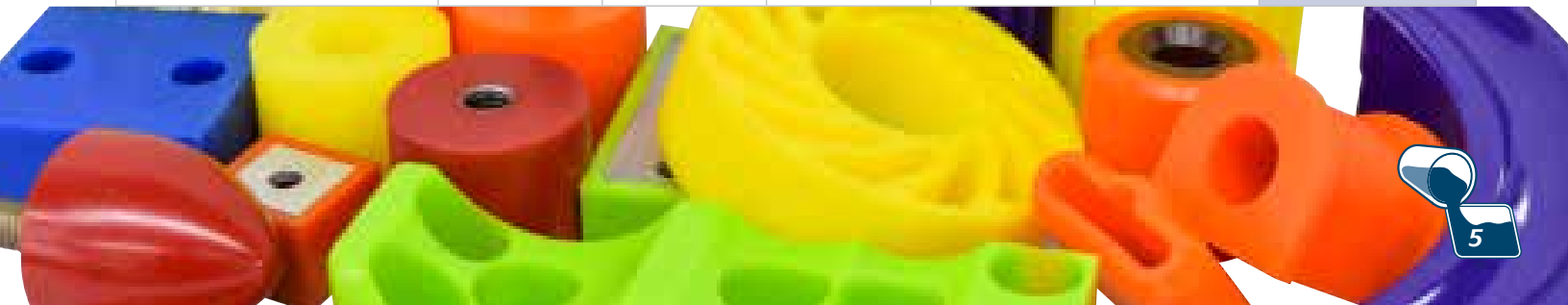

What is K•Prene®?

K•Prene® is the trade name for the various grades of urethane elastomers formulated specifically by **Acrotech**. The **K•Prene®** formulations were designed to “fill the gaps” between rubbers with characteristic resilience and structural plastics with characteristic hardness. The result is a functional toughness matched by no other available material in either natural or man-made form.

K•Prene® urethane elastomers have higher oil and solvent resistance and better thermal stability than most general purpose rubbers and plastics. They have greater abrasion and tear resistance in combination with increased load bearing capacity than do the neoprene or natural rubbers. Their extensibility and impact strength are greater than those of most plastics materials.

K•Prene® Urethane Characteristics

- TDI and MDI chemical structures, both are available in polyether and polyester formulas.
- We manufacture over 25 formulations on a daily basis.
- Hundreds of other formulations are available to meet your most demanding application.
- Shore scale hardness ranging from **10A to 85D** Durometer.

Technical information and important Urethane Charts can be found on our website: www.acrotechinc.com

Selecting K•Prene® for limitless applications

Urethane provides a unique combination of properties. **These include:** high load-bearing capacity; toughness; hardness; abrasion resistance; and oil and ozone resistance.



K-400A

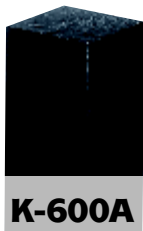

K-600A



K-800A

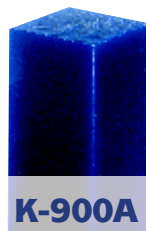

K-900A



K-950A

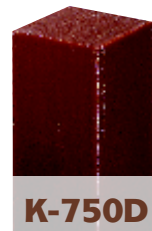

K-750D

K-400A Yellow 40A Durometer:

A low durometer material with a high coefficient of friction that will satisfy countless industrial needs such as rollers, bumpers, etc.

K-600A Black 60A Durometer:

High coefficient of friction and excellent tensile strength makes this material a good choice for feed rolls and many other industrial applications.

K-800A Orange 80A Durometer:

Good tear strength, abrasion resistance and excellent flex life. Good low temperature properties. Requires lower tonnage. Withstands greater deflection. Should not be used for material heavier than 20 gauge mild steel, except in special applications. Maximum recommended deflection 35%.

K-900A Blue 90A Durometer:

Withstands consistent flexing. Good cut resistance. Good load-bearing capacity. Recommended for most applications where large radius bends or difficult bends require large deflection or flow of K•Prene®. Maximum recommended deflection 25%.

K-950A Red 95A Durometer:

High tensile strength for higher blank-holding pressure. High load-bearing capacity. Best tear strength. Best cut resistance. Best abrasion/wear resistance. Recommended for most applications. Maximum recommended deflection 15%.

K-750D Brown 75D Durometer:

Great load-bearing capacity. Excellent machinability and abrasion resistance. Offers great rigidity, yet will deflect. Maximum recommended deflection 5%.







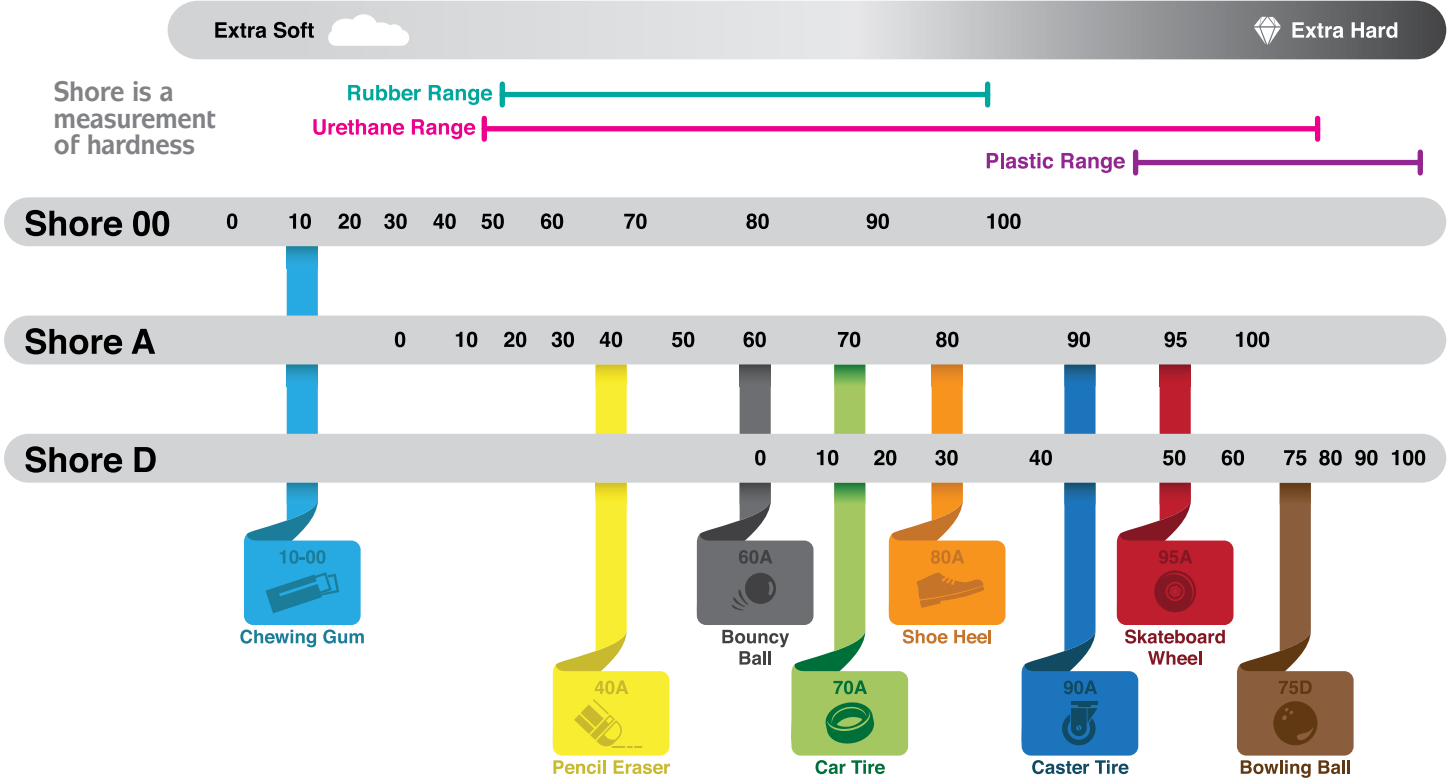

Our **K•Prene®** sample chains can be very helpful. Request your FREE sample keychain at: www.acrotechinc.com

DUROMETER HARDNESS SCALE



Physical Properties of K•Prene® Urethane

PROPERTIES	ASTM STD.	 K-400A	 K-600A	 K-800A	 K-900A	 K-950A	 K-750D
Hardness, Shore A	D-2240	40	60	80	90	95	—
Shore D	D-2240	—	—	—	43	50	75
Tensile Strength, (PSI)	D-412	500	3500	3000	5500	6500	9700
Elongation, %	D-412	510	530	800	430	380	250
100% Modulus, (PSI)	D-412	90	280	400	1100	1800	4900
300% Modulus, (PSI)	D-412	200	390	625	2200	4300	—
Tear Strength, Split, lb./in.	D-470	20	25	70	90	130	115
Tear Strength, Die C, lb./in.	D-624	80	180	400	600	700	770
Abrasion Resistance, NBS Index	D-1630	—	45	110	175	300	475
Impact Resistance							
(Izod) ft. lb./in.	D-256	—	—	—	—	—	5
Compression Set, Method B, %	D-395	38	6	45	30	36	—
Compression Set, Method A, %	D-395	—	—	—	—	—	1
Bashore Resilience, %	D-2632	8	32	60	42	40	44
Bell Brittle Point, F.	D-2137	—	-70	<-130	<-80	<-80	<-83
Coefficient of Friction	D-1894	—	—	0.55	0.45	0.30	0.11
Compression Modulus, 5%, (PSI)	D-575	13.3	40	150	272	515	1796
Compression Modulus, 10%, (PSI)	D-575	28.2	80	274	530	982	4509
Compression Modulus, 15%, (PSI)	D-575	43.8	130	378	735	1372	5996
Compression Modulus, 20%, (PSI)	D-575	—	180	492	940	1811	7266
Compression Modulus, 25%, (PSI)	D-575	82.7	240	641	1240	2358	8433
Specific Gravity	D-792	—	1.16	1.08	1.11	1.13	1.21



machining of K•Prene®

Machining of K•Prene® urethane proves useful when the required tolerances cannot be obtained by conventional molding methods, or when low production runs do not justify the cost of molds. We maintain a complete inventory of sheets, round rods, and bars in six different hardnesses which can often be used to make prototypes or limited production quantities.

The table below details the general machining characteristics of K•Prene® urethane 90A durometer and harder. For K•Prene® urethane below 80A durometer, cutting tools are often not satisfactory and grinding may be required. In some cases, machinability can be improved by freezing K•Prene urethane below 80A durometer with dry ice or liquid nitrogen.

Machining of K•Prene® urethane is similar to that of metals, and in most cases the same tools can be used.

The principle differences between metal and urethane machining are:

Modulus of Elasticity

Urethanes are resilient and can be easily distorted, so care must be taken to avoid distortion due to holding or cutting forces.

Softening Point

Gumming, poor finishes and poor dimensional control will readily occur if excess heat is generated and allowed to accumulate. Proper tool geometry, feed rates and cutting speed in conjunction with coolants can usually overcome these problems. Water-soluble cutting oils and/or light machine oils are good coolants for urethanes.

Lower Thermal Conductivity

Heat generated by the cutting tools stays close to the tool and raises the urethane temperature rapidly. This heat must be controlled. Melting can occur above 350° F.

Elastic Memory

Elastic recovery occurs in urethanes both during and after machining, so the cutting tool must provide clearance to compensate accordingly. Without compensation, expansion of the urethane after cutting will result in increased friction between the cut surface and the cutting tool. Excess heat build-up will result. Elastic recovery after machining can result in smaller internal diameters or larger external diameters than were measured during cutting.

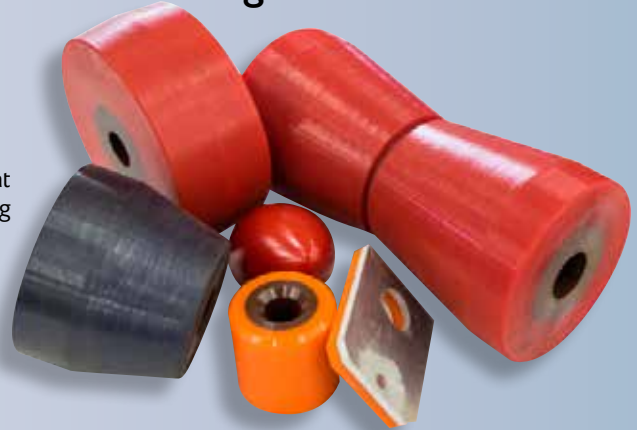

MACHINING APPLICATIONS	RECOMMENDED TOOLS	SIZE LIMITATIONS	MAXIMUM SPEEDS	WORKHOLDING RECOMMENDATIONS	SUGGESTIONS
Bandsawing	Sharp 2-4 hook carbide blade with raker set.	Max. 8" thick Min. 1/8" thick sheets.	1800 ft./min. (reduce to 1200 ft./min below 90A).	Vises or clamps (Not required with flats or sheets).	<ul style="list-style-type: none"> Rotate rounds when sawing. Maintain high blade tension.
Cutting, Shearing, Slitting	Shears or belt-cutting machines with up to 1/8" knife blade	Thin sheets (up to 1/2").		Friction clamps.	<ul style="list-style-type: none"> Use bevel edge blades (square degree, compress urethane, resulting in uneven cuts).
Drilling	High speed 90° + twist drills with blunt point.	Min. of 3/8" (no minimum if clamped between steel).	600-800 RPM	Vises or clamps.	<ul style="list-style-type: none"> Good tolerances possible with 75D, for other grades use over-size drills.
Tapping	Regular high speed taps.	None		Vises or clamps.	<ul style="list-style-type: none"> Except for 75D, use over-size tap to allow for shrinkage or urethane.
Turning Boring	H.S.S. tool bits with positive rake of 5°-10°.	No limits on dia. length restricted (long soft bars may flex).	800 surface ft./min.	Angle of cut to work: 90° - 120°.	<ul style="list-style-type: none"> Form tools may be used (especially when machining 75D).
Grinding	Tool post grinder 20-80 grit wheel.		Lathe-150 RPM or lower. Grinder-2000-3500 RPM.	Fixtures or friction mandrels.	<ul style="list-style-type: none"> Air blast to eliminate build up.
Knifing	Carbide or H.H.S. razor sharp and as thin as possible.		600-1000 RPM	Fixtures or friction mandrels.	<ul style="list-style-type: none"> Use lubricant to help prevent dishing.
Milling	Sharp single-blade flycutters with 10° back rake and good clearance.	Min. 3/8" thick	Approx. 2000 surface ft./min.	Vise or double-face clamping tape.	<ul style="list-style-type: none"> Flycutting at approx. 3" dia. give best results.

STANDARD URETHANE



precision cast sheets

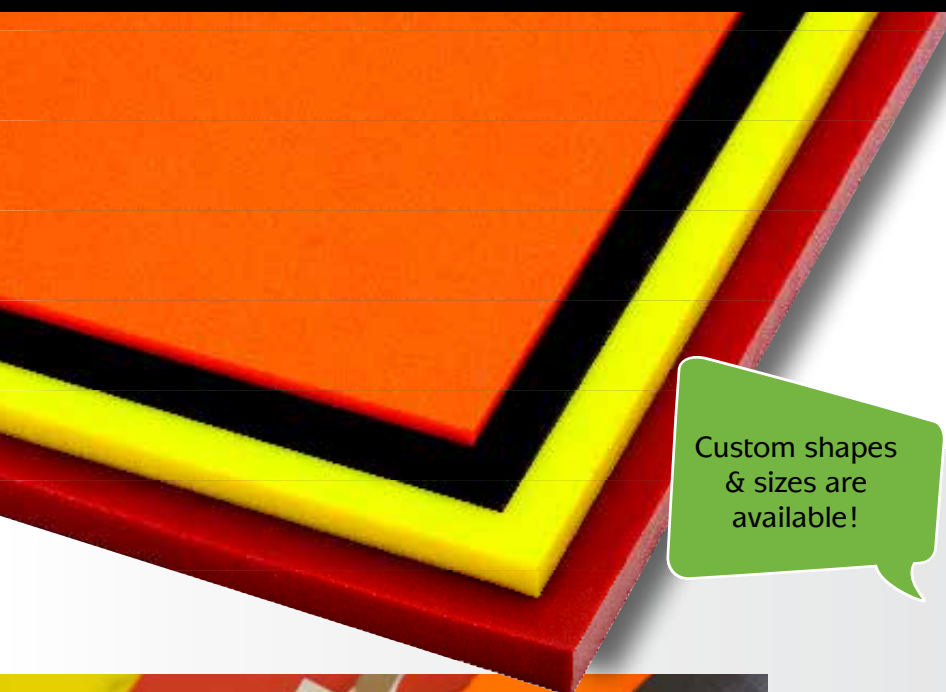

Custom shapes & sizes are available!

- Sheets 1" and UNDER are available in **40A, 60A, 80A, 90A, 95A** and **75D** durometer.
- Can be cut to size – Used for any application
- **Pricing available online:** www.acrotechinc.com

Tolerances:

Length: +1/4 - 0

Width: +1/4 - 0

Thickness: + / - 2% or + / - .010 (whichever is greater)

Standard Available Sheets

AVAILABLE THICKNESS (inches)	WIDTH (inches)	LENGTH MAX (inches)
1/16	1 - 24	72
1/8	1 - 24	72
3/16	1 - 24	72
1/4	1 - 48	96
3/8	1 - 48	96
1/2	1 - 48	96
5/8	1 - 48	96
3/4	1 - 48	96
1	1 - 48	96

Fractional increments up to 6" are custom, please call for availability

1-1/16 thru 6	UP TO 48	UP TO 96
---------------	----------	----------



Inspected and measured for tolerance and accuracy

round rods

- Standard rounds available in **40A, 60A, 80A, 90A, 95A** and **75D** durometer.
- Diameters over 4" and larger are available upon request
- Can be cut to size – Used for any application
- Tolerance: Width & Height +/- .010, or 2% in Length – (Whichever is greater)
- **Pricing available online:** www.acrotechinc.com

Standard Sizes

DIAMETER (inches)	LENGTH (inches)
1/4	12, 24
3/8	12, 24
1/2	12, 24, 36, 48
5/8	12, 24, 36, 48
3/4	12, 24, 36, 48
7/8	12, 24, 36, 48
1	12, 24, 36, 48
1-1/8	12, 24, 36, 48
1-1/4	12, 24, 36, 48
1-3/8	12, 24, 36, 48
1-1/2	12, 24, 36, 48
1-5/8	12, 24, 36, 48
1-3/4	12, 24, 36, 48
1-7/8	12, 24, 36, 48
2	12, 24, 36, 48
2-1/8	12, 24, 36, 48
2-1/4	12, 24, 36, 48
2-3/8	12, 24, 36, 48
2-1/2	12, 24, 36, 48
2-3/4	12, 24, 36, 48
3	12, 24, 36, 48
3-1/8	12, 24, 36, 48
3-1/4	12, 24, 36, 48
3-1/2	12, 24, 36, 48
3-3/4	12, 24, 36, 48
4	12, 24, 36, 48

Metric Rounds (Made to order)

DIAMETER (mm)	LENGTH (mm)
8	500
10	500
15	500, 1000
20	500, 1000
25	500, 1000
30	500, 1000
40	500, 1000
50	500, 1000
60	500, 1000
70	500, 1000
80	500, 1000
100	500, 1000

4"+ please call for availability

Custom shapes & sizes are available!



square & rectangle bars



- Available in **40A, 60A, 80A, 90A, 95A** and **75D** durometer.
- Custom made thicknesses available upon request
- Can be cut to size – Used for any application
- Tolerance: Width & Height +/- .010, or 2% in Length – (Whichever is greater)
- **Pricing available online:** www.acrotechinc.com

Standard Sizes

WIDTH x HEIGHT (inches)	LENGTHS (inches)
3/8 x 3/8	12, 24, 36, 48
1/2 x 1/2	12, 24, 36, 48
5/8 x 5/8	12, 24, 36, 48
3/4 x 3/4	12, 24, 36, 48
1 x 1	12, 24, 36, 48
1-1/4 x 1-1/4	12, 24, 36, 48
1-1/2 x 1-1/2	12, 24, 36, 48
1-3/4 x 1-3/4	12, 24, 36, 48
*2 x 2	12, 24, 36, 48
2-1/2 x 2-1/2	12, 24, 36, 48
*3 x 2	12, 24, 36, 48
3 x 3	12, 24, 36, 48
4 x 4	12, 24, 36, 48
5 x 5	12, 24, 36, 48

6"+ are custom, please call for availability

(*) can be ordered with a 1" center hole

When ordering this please specify **"WITH CENTER HOLE"**

Custom shapes
& sizes are
available!

Metric Sizes (Made to order)

WIDTH x HEIGHT (mm)	LENGTHS (mm)
25 x 25	500, 1000
**30 x 30	500, 1000
**50 x 50	500, 1000
**80 x 30	500, 1000
75 x 50	500, 1000
**110 x 45	500, 1000

(**) Fits European style bottom dies

tubes/springs

Our urethane tube and spring selection is among the largest available in the industry, with hundreds of mold combinations available to pour the perfect size. Tubes and springs can be used for any application and we encourage you to check out our website for further sizing and pricing information. Depending on your custom applications we can tailor these to specific durometers and colors.

Check out www.acrotechinc.com for more information and pricing.



- Abrasion resistance
- Urethane does not fragmentize
- High load-carrying capability
- Protection from marring/galling
- Oil and solvent resistance
- Longer life
- Low noise
- 100% load-bearing surface
- Vibration damping & shock absorbance
- Can be custom cut upon request
- Effectiveness between -30°F and 180°F
- Tolerance: Width & Height +/- .010, or 2% in Length - (Whichever is greater)
- **Pricing available online:** www.acrotechinc.com

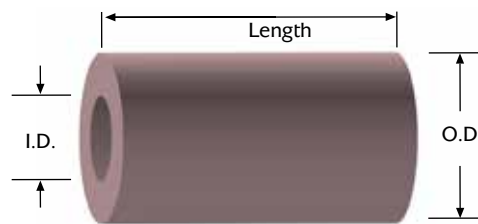

Contact us for custom I.D.'s, O.D.'s and Lengths.

Tubes/Springs – Metric
(Made to order)
Custom lengths upon request

I.D. (mm)	O.D. (mm)	Length Options (mm)
7	15	500
8.5	20	500
11	25	500
14	30	500
14	40	500
14	50	500
14	60	500
22	80	500
22	100	500

I.D. Ranges (inches)	O.D. Ranges (inches)	Lengths (inches)
1/8 thru 25/64	3/8 thru 3	12
7/16 thru 4	3/4 thru 5	24

washers, seals & gaskets

- Almost any O.D./I.D. combination can be supplied.
- We have provided parts in quantities of thousands to just a few pieces.
- Durometer, size, color, etc., all supplied to your specifications.
- **Pricing available online:** www.acrotechinc.com

Bulk or specific quantity packaging is available





roller re-manufacturing & re-covering

Acrotech can strip and recover almost any type of roller that you have. We are able to take down the current materials to the core and recover in any hardness of urethane that you would need. Special grooves, angles, widths and depths are also available when recovering your rollers with urethane at Acrotech.

Before



After

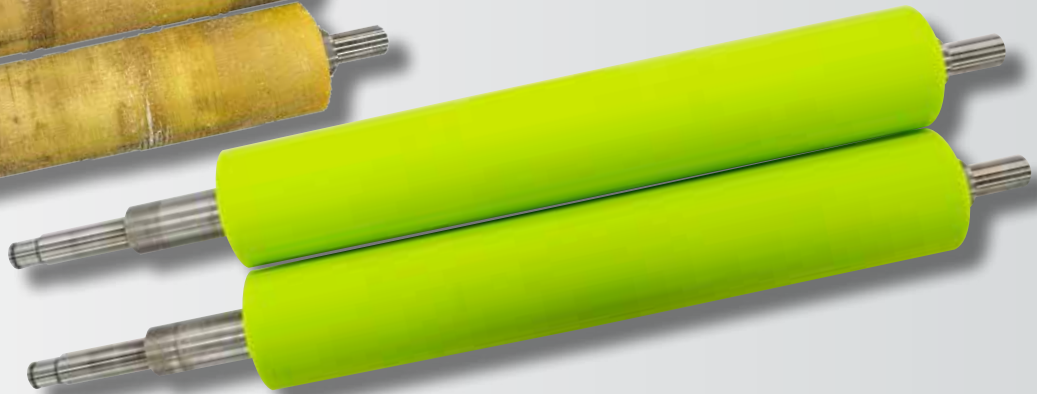

Several groove types, angles, widths and depths are available.

Smooth



Vertical



Horizontal



Herring Bone



Serrate



Diamond



bumpers

- Steel cores with male or female threads.
- Standard Bumpers are available in **40A, 60A, 80A, 90A, and 95A** durometer.
- **Pricing available online:** www.acrotechinc.com

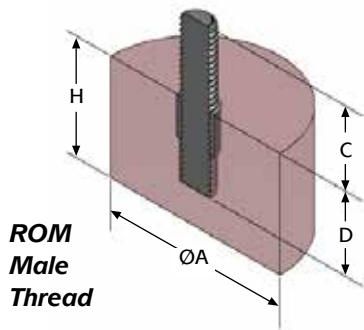

**ROM
Male
Thread**

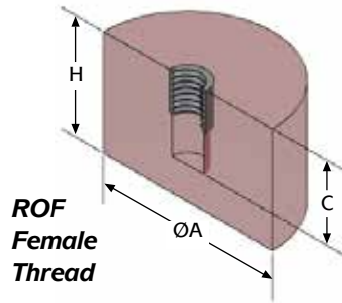

**ROF
Female
Thread**

Custom shapes
& sizes are
available!

Standard Round Bumpers (ROM)

A (inches)	H (inches)	C & D (inches)	Thread (inches)	Part No.
1	1	3/4	1/4 - 20	ROM001
1-1/4	1	3/4	1/4 - 20	ROM002
1-1/2	1-1/4	7/8	3/8 - 16	ROM003
2	1-1/4	7/8	3/8 - 16	ROM004
2-1/2	2	1	1/2 - 13	ROM005
3	2-1/2	1	1/2 - 13	ROM006

Standard Round Bumpers (ROF)

A (inches)	H (inches)	C (inches)	Thread (inches)	Part No.
1	1	3/4	1/4 - 20	ROF001
1-1/4	1	3/4	1/4 - 20	ROF002
1-1/2	1-1/4	7/8	3/8 - 16	ROF003
2	1-1/4	7/8	3/8 - 16	ROF004
2-1/2	2	1	1/2 - 13	ROF005
3	2-1/2	1	1/2 - 13	ROF006

- A flat washer is molded into the bumper and will accept a socket head cap screw of the size indicated.
- Available in **40A, 60A, 80A, 90A, and 95A** durometer.
- **Pricing available online:** www.acrotechinc.com

Standard Washer Sizes (RON)

A (inches)	H (inches)	C (inches)	Cap Screw (inches)	Part No.
3/4	3/4	.250	1/4	RON001
1	1	.500	1/4	RON002
1-1/4	1	.750	3/8	RON003
1-1/2	1-1/4	.750	3/8	RON004
2	1-1/4	.750	1/2	RON005
2-1/2	2	.750	1/2	RON006
3	2-1/2	.750	1/2	RON007

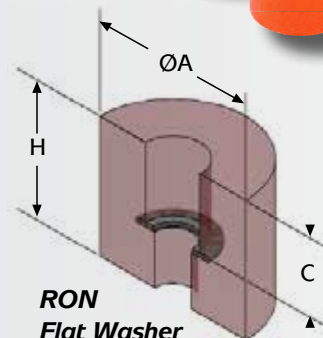

**RON
Flat Washer**

Custom shapes
& sizes are
available!

bumpers

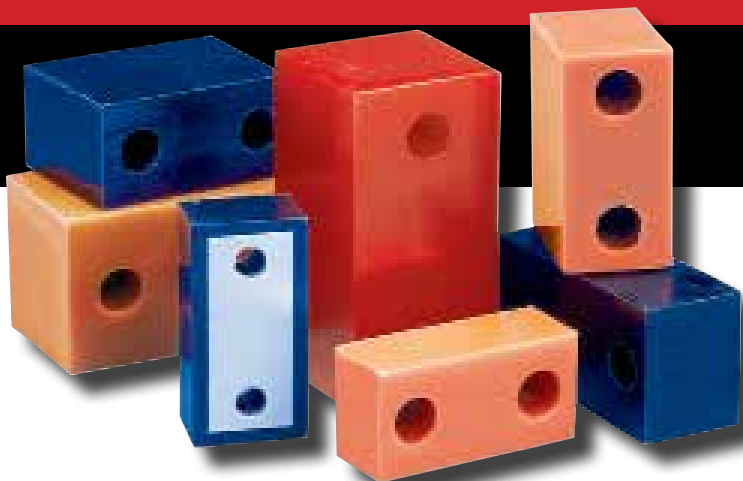

- Square and Rectangular bumpers are molded with a 1/8" aluminum base plate.
- Standard bumpers are available in **40A, 60A, 80A, 90A,** and **95A** durometer.
- **Pricing available online:** www.acrotechinc.com

Counterbored to accept standard 1/4" socket head cap screws

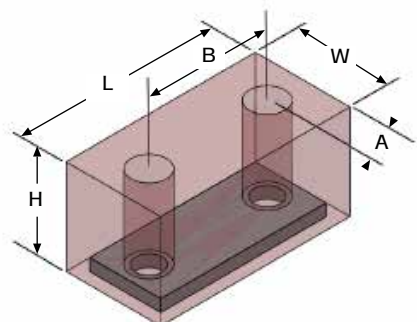

Rectangle Bumpers (REC)

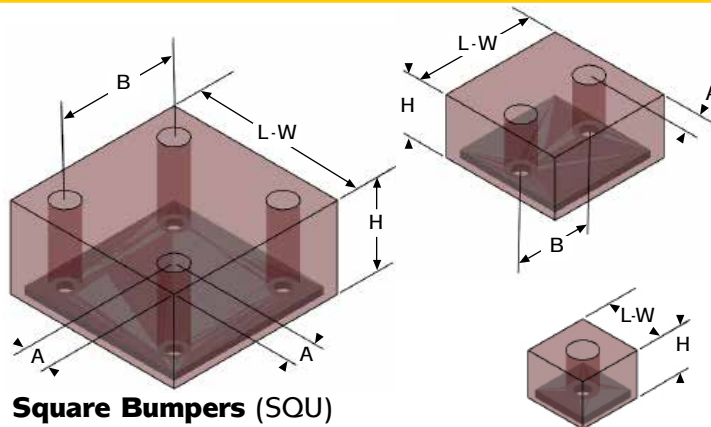

Square Bumpers (SQU)

W (inches)	L (inches)	H (inches)	A (inches)	B (inches)	Part No.
1	2	1/2	3/8	1-1/4	REC001
1	2	3/4	3/8	1-1/4	REC002
1	2	1	3/8	1-1/4	REC003
1	2	1-1/2	3/8	1-1/4	REC004
1-1/4	2-1/2	3/4	3/8	1-3/4	REC005
1-1/4	2-1/2	1	3/8	1-3/4	REC006
1-1/4	2-1/2	1-1/2	3/8	1-3/4	REC007
1-1/2	3	3/4	1/2	2	REC008
1-1/2	3	1	1/2	2	REC009
1-1/2	3	1-1/2	1/2	2	REC0010

L-W (inches)	H (inches)	A (inches)	B (inches)	Part No.
1	3/4	1 Hole Centered		SQU001
1-1/2	1	3/8	3/4	SQU002
2	1	3/8	1-1/4	SQU003
2-1/2	1	1/2	1-1/2	SQU004
3	1-1/2	1/2	2	SQU005
4	1-1/2	1/2	3	SQU006

custom bumpers

Acrotech has made bumpers in countless shapes and sizes. Contact our applications department with any possible applications you would like to discuss. In addition to a general description, a print or a sketch, sample parts would be helpful if available.



versa roll™

Versa Rolls™ are a low-cost alternative for wheels, casters, rollers, sheaves, etc. They are easily machinable and profiled to fit your applications.

- Two grades of tough K•Prene® urethane permanently bonded together, resulting in a hard anti-friction hub with softer outer tire.
- Available with a **90A** outer tire and an anti-friction **75D** hub.
- I.D.'s are slightly oversized to provide running clearance for 3/8" to 1" shafts.
- Tolerance: Width & Height +/- .010, or 2% in Length - (Whichever is greater).
- **75D** hub can serve as a bearing in some applications.
- Use to make low cost OEM components for your manufactured products.
- **Pricing available online:** www.acrotechinc.com

For special applications, other durometers are available!

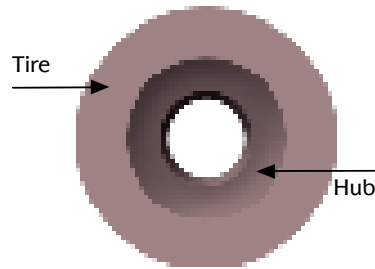

Standard Versa Roll™ Sizes (✓ = Available)

Tire O.D. (inches)	Hub O.D. (inches)	Hub I.D. (inches)	Part Number	12" Length	24" Length
1-1/2	3/4	3/8	KVR15075375	✓	—
	1	No Bore	KVR1510000	✓	—
	1	3/8	KVR1510375	✓	—
	1	1/2	KVR1510500	✓	—
	1	3/4	KVR1510750	—	✓
1-3/4	1	3/8	KVR17510375	✓	—
1-7/8	1	1/2	KVR187510500	✓	—
2	1	1/4	KVR2010250	✓	—
	1	3/8	KVR2010375	✓	—
	1	1/2	KVR2010500	✓	—
	1-1/2	3/8	KVR2015375	✓	—
	1-1/2	1/2	KVR2015500	✓	—
	1-1/2	5/8	KVR2015625	✓	✓
	1-1/2	3/4	KVR2015750	✓	✓
	1-1/2	7/8	KVR2015875	✓	✓
	1-1/2	1	KVR2015100	✓	✓
	2-1/2	1-1/2	3/8	KVR2515375	✓
1-1/2		1/2	KVR2515500	✓	—
1-1/2		5/8	KVR2515625	✓	✓
1-1/2		3/4	KVR2515750	✓	✓
1-1/2		1	KVR2515100	✓	✓
2-3/4	1-1/2	1/2	KVR27515500	✓	—
	1-1/2	5/8	KVR27515625	✓	✓
3	1-1/2	No Bore	KVR3015000	✓	✓
	1-1/2	3/8	KVR3015375	✓	—
	1-1/2	1/2	KVR3015500	✓	—
	1-1/2	5/8	KVR3015625	✓	✓

Tire O.D. (inches)	Hub O.D. (inches)	Hub I.D. (inches)	Part Number	12" Length	24" Length
3	1-1/2	3/4	KVR3015750	✓	✓
	2	1	KVR3020100	✓	✓
3-1/2	1-1/2	3/8	KVR3515375	✓	—
	1-1/2	1/2	KVR3515500	✓	—
	1-1/2	5/8	KVR3515625	✓	✓
	1-1/2	3/4	KVR3515750	✓	✓
3-3/4	2-1/2	3/4	KVR3525750	✓	—
	2	1	KVR37520100	✓	✓
4	1-1/2	3/8	KVR4015375	✓	—
	1-1/2	1/2	KVR4015500	✓	—
	1-1/2	5/8	KVR4015625	✓	✓
	1-1/2	3/4	KVR4015750	✓	✓
	2	1	KVR4020100	✓	✓
4-1/2	3	1	KVR4030100	✓	✓
	2	1	KVR4520100	✓	✓
	5	1-1/2	3/8	KVR5015375	✓
5	1-1/2	1/2	KVR5015500	✓	—
	1-1/2	5/8	KVR5015625	✓	✓
	1-1/2	3/4	KVR5015750	✓	✓
	2	1	KVR5020100	✓	✓
6	1-1/2	3/8	KVR6015375	✓	—
	1-1/2	1/2	KVR6015500	✓	—
	1-1/2	5/8	KVR6015625	✓	✓
	1-1/2	3/4	KVR6015750	✓	✓
	2	1	KVR6020100	✓	✓
6-1/2	5	1-1/2	KVR6550150	✓	✓

solid urethane balls

Made to order in several durometers and offered in different colors.
Please specify durometer.



Urethane balls can be used for:

- Check valves
- Relief valves
- Light load ball bearings
- **Pricing available online:**
www.acrotechinc.com

Diameter (inches)	Part No.
3/4	Ball0304
1	Ball1000
1-1/2	Ball1102
1-5/8	Ball1508
2	Ball2000
2-1/2	Ball2102
2-5/8	Ball2508
3	Ball3000

metal backed sheets

Cut, drill, and saw these sheets to suit your needs. Make your own bumpers, wear pads, machinery mounts, etc. Backing is 10 ga. (.135) mild steel. Available in any standard durometer. Other backings or urethane thicknesses available.



Urethane Thickness (inches)	Standard Sizes (inches)
1/4	6 x 6, 12 x 12 or 24 x 24
3/8	
1/2	
5/8	
3/4	
7/8	
1	

hammer

The Acrotech Hammer is made from 75D urethane. It is a harder hammer but not exactly a dead blow. Urethane hammers have more bounce to them but will not mark or mar material. They are long lasting and highly durable. We are able to make custom hammers for you or with your logo or your specifications.

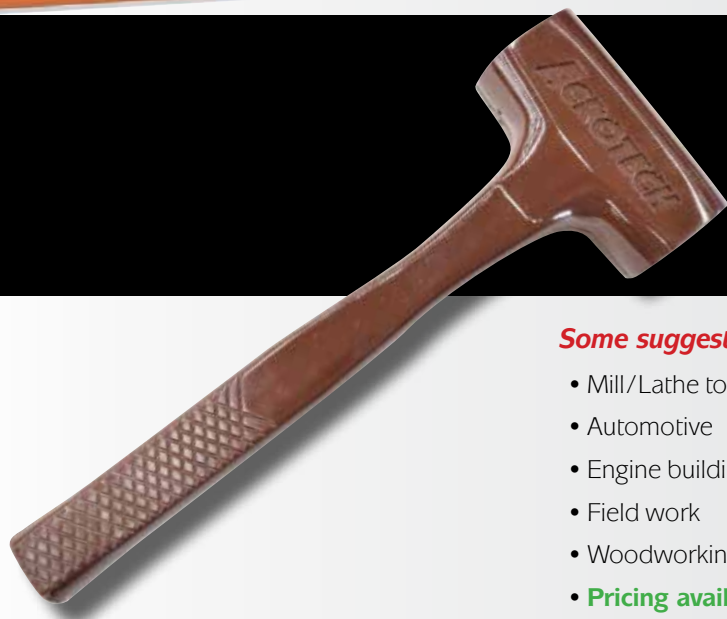

Some suggested uses for this hammer:

- Mill/Lathe tool changing
- Automotive
- Engine building
- Field work
- Woodworking
- **Pricing available online:** www.acrotechinc.com

Durometer	Part No.
75D	UHM0125

tool holsters

Designed to reduce costly repairs and down time of expensive pneumatic tools used in fast paced assembly lines. Available in K•Prene® 90A which is hard and slick, insuring easy-in and easy-out, yet will flex upon contact. Mounting holes at top and bottom mean secure and easy installation. Contact our factory for additional sizes or styles.

• Pricing available online: www.acrotechinc.com

Taper ID	Cup Length	Overall Length	Part No.
4" to 1-1/2"	5"	7-1/2"	500-0221
Straight ID 2"	5-3/4"	6-1/4"	500-9201



slick strip™ tape (10mil.)

When applied to metal surfaces, this pressure sensitive tape will reduce friction and protect finished stock (wood, metal, etc.) from scratches and dents. To apply, cut to length with scissors, remove adhesive protector and apply to clean, dry surface. Work hardens.

Width (inches)	Length	Part No.
1	36 yards	SST1001
1-1/2	36 yards	SST1015
2	36 yards	SST1002
3	36 yards	SST1003
4	36 yards	SST1004
6	36 yards	SST1006
22	10' min.	SST1022

- UHMW Polyethylene
- 4 mil. backing
- Withstands temperatures up to 150° F.

• Pricing available online: www.acrotechinc.com



k-20 adhesive

Especially formulated to withstand continuous flexing. Exhibits great strength when used to bond K•Prene® to K•Prene®, metal, or plastic. Two-part kit composed of equal containers of resin and hardener.

- For applying urethane - to - urethane OR urethane - to - steel.
- K-20 has high tensile strength, yet remains flexible to withstand continuous shock of press strokes.
- Composed of a two-part A and B kit. 1+ year shelf life.
- Pricing available online: www.acrotechinc.com

Description	Part No.
1/2 Pint Kit (2 - 1/4 Pint Cans)	KPA202
1 Pint Kit (2 - 1/2 Pint Cans)	KPA203
2 Pint Kit (2 - 1 Pint Cans)	KPA204



K-20 Adhesive Applications:

- Wear pads
- Clamping pads
- Stripping pads
- Pressure pads
- Embossing pads
- Wiping blocks
- Fixture blocks
- Urethane die pads
- Steel clamping plates
- Steel stripper plates
- Steel pressure plates
- Steel sub-plates
- Steel holders

• 45 minute pot life • 12 hour cure time • 2-3 day full cure

urethane drive wheels



- Available in **80A** durometer – other durometer's are available upon request.
- Tires/Wheels can be used in other applications to drive various other materials beyond wood without marking or damaging.
- Non-marking: Won't mark pre-surfaced or pre-finished stock as does steel or rubber wheels.
- Eliminates slippage: Excellent traction out performing steel wheels and they provide feed control for higher output.
- Gone are Raised Grain Problems: The high-friction of the tire/wheel provides more traction with less pressure, eliminating the major cause of raised grain. This will increase the overall quality of the product
- Economical to use: Tires/Wheel are easy and quick to change.
- **Pricing available online:** www.acrotechinc.com

3 Hole Bolt Pattern

O.D. (inches)	I.D. (inches)	Width (inches)	Part No.
4-3/4	2	2	DW30009
5-1/2	2-3/16	2	DW30010
5-1/2	2-3/8	2	DW30011
6	2-1/4	2	DW30012
6-5/16	2-3/4	2	DW30013
6-5/8	2-3/4	1	DW30014
6/5/8	2-3/4	2	DW30015
7	2-1/4	2	DW30016
8-3/4	4	2	DW30017
6	2-3/4	2	DW30018
5-1/2	3	2	DW30019
7-5/16	2-3/4	2	DW30020
5-1/2	3	1	DW30021
5-1/2	2-1/4	3/4	DW30022
5-1/2	2-1/4	2	DW30023

DESIGNED WITH 3 OR 6 BOLT MOUNTING HOLES to fit various re-usable hubs on woodworking **Moulders, Planers and Re-Saws** like:

- Weining®
- Mattison®
- Baker®
- SCMI®
- Bridgewood®
- Extema®
- Wadkin®
- Diehl®
- ... and more

6 Hole Bolt Pattern

O.D. (inches)	I.D. (inches)	Width (inches)	Part No.
4-3/4	3	3/4	DW60040
5-1/2	3	3/4	DW60041
6-5/8	3-3/8	3/4	DW60042
4-3/4	3	2	DW60043
6	3	3/4	DW60047

re-covering bonded drive wheels



Weinig® Molders Available in **80A** durometer.

O.D. (inches)	Width (inches)	Part No.
5-1/2	2	500-0079
5-1/2	1-3/16	500-0080
5-1/2	3/4	500-0081
4-1/2	2	500-1102

power feed tires

Urethane tires feed better and cost less than the rubber-coated hubs which are standard on many feeders.

- Available in **60A** durometer – other durometer’s are available upon request.
- Durometer **70A** recommended for rough stock and **60A** recommended for smooth surfaces.

REPLACEMENT TIRE ONLY: Tire fits re-usable 2 piece hub

POWER FEEDER MODELS: Fits most import and standard domestic feeders and Cantek and Co-matic models AF38, AF48. **Other models include:**

- Silver® • Nortech® • Powermatic® ...and others

6 Hole Bolt Pattern

O.D. (inches)	Width (inches)	Part No.
4-3/4	2-3/8	SHT0066



press fit power feed tires

- Urethane tires feed better and cost less than the rubber-coated hubs which are standard on many feeders.
- Urethane tires are available in **60A** Durometer – other durometer’s are available upon request.
- Durometer **70A** recommended for rough stock and **60A** recommended for smooth surfaces.

Fits models like: **Powermatic®, Maggi®, Steff®, Univer®, Rockwell®, Oliver®, Forest City®... and many more.**

Also made to fit **PFH-0070 standard hub. (fig. 1)**

Description	O.D. (inches)	Width (inches)	Part No.
Tire	3	1	PFT0060
Tire	4-3/8	1-3/4	PFT0061
Tire	4-7/8	1-3/4	PFT0062
Tire	4-3/8	2	PFT0063
Tire	4-3/8	2-1/4	PFT0064
Tire	4-3/8	2	*PFT0065

***This ribbed design works best for slick surfaces. Tire OD's increase when installed.**

Hub - Fits all tires except PFT-0060	PFH0070
Tire mounting tools (see fig. 2)	PFHTOOL



Assembled: Tire will expand after pressing on hub. OD size listed is before pressing on hub.

Narrow Stock: PFT-0063 is recommended for stock 1" wide or less.

re-covering bonded power feed wheels

Description	O.D. (inches)	Width (inches)	Part No.
SMALL Power Feeder-Commatic®, Delta®, Grizzly® etc.	3-1/8	1-1/8	RFP001
LARGE Power Feeder-Delta®, Jet®, Nandini®, Steff®, Maggi® etc.	4-5/8	2	RFP002



high performance

K•Prene® has become a great option for numerous automotive racing applications. Due to ongoing efforts with handling and increasing speed, K•prene® urethane is a material that many use as an advantage in the competitive racing field. Racing is not the only market where urethane is used, OEM manufacturers can benefit from the long lasting, strong, abrasion resistant characteristics of urethane.



5"-5-1/2" Springs

3"-3-1/2" Springs

spring rubbers

Coil Over Spring Rubbers for 3"-3-1/2" Springs

Thickness (inches)
.600
.700
.850
1

Spring Rubbers for 5"-5-1/2" Springs

Thickness (inches)
1/2
5/8
3/4
7/8
1
1-1/8
1-1/4
1-3/8
1-1/2
1-5/8
1-3/4
1-7/8
2
2-1/8
2-1/4
2-1/2
2-3/4
3

- Use dimensions, between coil springs to determine part size.
- Cut part and feed in between coil springs.
- Approximate clearance between bottom of coil spring and top of rubber radius is 1/4".
- Pullouts are optional.
- **Pricing available online:** www.acrotechinc.com

Durometer: (hardness color table)

- **40A:** Soft
- **60A:** Hard
- **80A:** X Hard
- **95A:** XX Hard

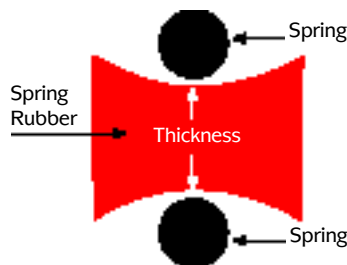

Can be further customized.
Call for details:
1-800-345-0583

automotive & other high performance applications

- There are many K•Prene® applications for the automotive industry.
- They weigh less than existing metal parts and have significant tensile strength.
- Sway bar (stabilizer bar) bushings
- Control arm bushings
- Leaf spring bushings
- Strut rod bushings
- Shock bushings
- Bump stops and street stops
- Shock reservoir isolators

... or many other custom applications that your automobile, motorcycle or snowmobile needs may require.



METAL FORMING



Metal Forming Applications Using Urethane

Why use K•Prene® urethane in forming applications? There are several families of urethane elastomers, but not all of them will perform equally well. Even within one grade of a given urethane formulation, cured properties can vary widely. K•Prene® urethane is specifically compounded and processed by Acrotech Inc., to maximize the characteristics desired for optimum tool and die operation. Some of the major advantages of urethane are non-compressibility, resiliency, and the ability to form and hold metal without marring its surface finish. It behaves similar to a solid fluid with a memory; under force it will change its shape, but its volume will remain constant. Urethane will produce high, uniform and continuous counter pressure under load. And, when the load is removed, it quickly returns to its original shape.

Application Examples where K-Prene® Urethane Can Be Used in Metal Forming

Radius Forming with Deflector Bars

Urethane die with deflector bars positioned under pad. Bars are graduated in size to control deflection of urethane. This helps form the difficult bends.

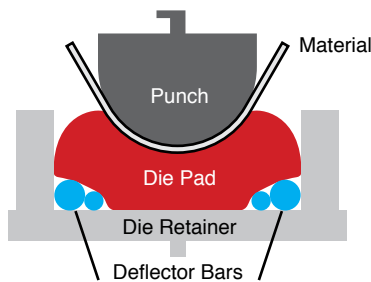

Universal Die Pad

The urethane pad for a female die is both economical and versatile. A single pad can be used for several applications.

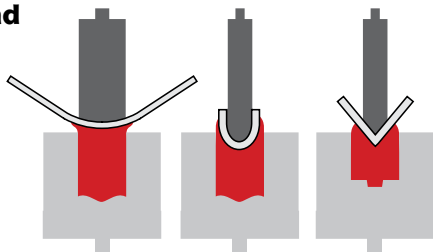

Die Springs

Urethane is economical and provides greater forces per deflection than conventional steel springs. Urethane creates counter acting force (cushion) when deflected or compressed.

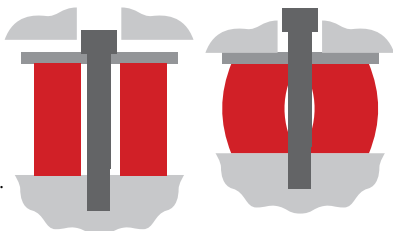

Bulging Punch

In bulging applications, urethane offers much longer service life than rubber, and is very cost effective compared to expanding/shrinking steel punches. Displacement of a urethane punch under compression forces metal outward into the desired shape. The amount of bulge is determined by the depth of stroke. When the ram is raised (after stroke), urethane will resume its normal shape and the bulged part can be easily removed.

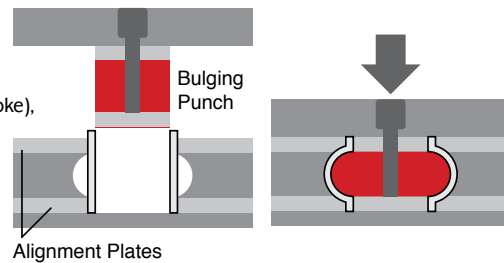

Stripping Pad for Punching

A standard urethane pressure pad is machined to fit around the punch. This is an easy, economical method of constructing a durable, oil resistant, high pressure stripping pad.

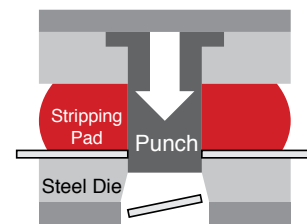

Roll Bending

A rotating steel shaft coated with K•Prene® working with another steel shaft positioned directly above, results in round parts with little or no flats on the leading or trailing ends.

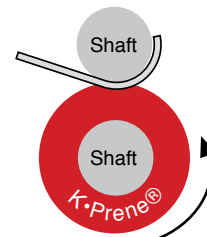

acro-hyde™

Acro-Hyde™ for press brake forming

Acro-Hyde™ is an exceptionally thin Urethane film that is commonly used in Metalworking and fabrication. It's primary useage is to prevent die marks in stainless, aluminum, and other painted or polished metals.

- Pricing available online:
www.acrotechinc.com

Contact us for
quantity discounts and
samples. View website
for more information:
www.acrotechinc.com

General Properties:	Specifications	Values
Durometer:	D2240	85A
Specific Gravity:	D792	1.20
Tensile Properties:	D638	
Modulus at 100% strain		800 psi
Modulus at 300% strain		1800 psi
Modulus at break		7000 psi
Modulus of elasticity up to 10% strain		30 psi
Elongation at break		400%
Set at break		30%
Tear Properties:		
Die C	D624	425pli

Description	Part No.
.015 x 2" wide x 100 ft.	ACH02015
.015 x 4" wide x 100 ft.	ACH04015
.015 x 6" wide x 100 ft.	ACH06015
.030 x 6" wide x 100 ft.	ACH06030
.015 x 12" wide x 100 ft.	ACH12015
.030 x 12" wide x 100 ft.	ACH12030
.015 x 18" wide x 100 ft.	ACH18015
.030 x 18" wide x 100 ft.	ACH18030
.015 x 36" wide x 20 ft.(min.)	ACH36015
.030 x 36" wide x 20 ft.(min.)	ACH36030

See how effective Acro-Hyde™ is with a sample piece of 18GA steel that has been painted. Adding Clamping Tape to your female die will help keep Acro-Hyde™ in place for repeated use / production bending.

This is an example of how easy the metal gets marked when it is formed with no protection on the die. The die easily makes scratches and grooves in the metals surface.

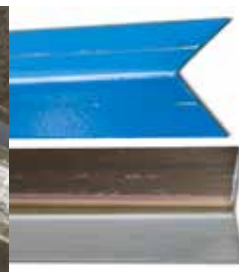

**BENT WITHOUT
ACRO-HYDE™**
Painted 18GA Steel
Polished 18GA Stainless

This is the same piece of painted steel that is formed with only the addition of Acro-Hyde™ to the outer surface of the metal. No grooves, marks or scratches to the paint. The part is ready for final assembly.

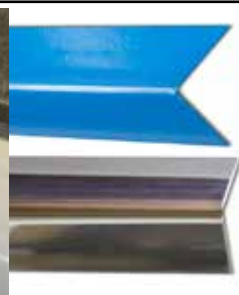
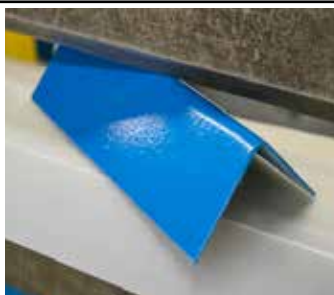

**BENT USING
ACRO-HYDE™**
Painted 18GA Steel
Polished 18GA Stainless

press brake dies

90 Degree Dies

Dimensions	Part No.-Lgth.
<p>1/4" 1-3/4" TYP 1-1/4" TYP</p> <p>Up to 22ga. M.S.</p>	KBDV010412
	KBDV010424
	KBDV010436
	KBDV010448
<p>3/8"</p> <p>Up to 18ga. M.S.</p>	KBDV030812
	KBDV030824
	KBDV030836
	KBDV030848
<p>1/2"</p> <p>Up to 16ga. M.S.</p>	KBDV010212
	KBDV010224
	KBDV010236
	KBDV010248
<p>5/8" 1-7/8" TYP 1-3/4" TYP</p> <p>Up to 14ga. M.S.</p>	KBDV050812
	KBDV050824
	KBDV050836
<p>3/4"</p> <p>Up to 13ga. M.S.</p>	KBDV030412
	KBDV030424
	KBDV030436
<p>7/8"</p> <p>Up to 12ga. M.S.</p>	KBDV070812
	KBDV070824
	KBDV070836
<p>1"</p> <p>Up to 11ga. M.S.</p>	KBDV100012
	KBDV100024
	KBDV100036
	KBDV100048

85 Degree Dies

Dimensions	Part No.-Lgth.
<p>1-1/4" 2" TYP 2-1/2" TYP</p> <p>Up to 12ga. S.S.</p>	KBDV110412
	KBDV110424
	KBDV110436
	KBDV110448
<p>1-1/2"</p> <p>Up to 10ga. S.S.</p>	KBDV110212
	KBDV110224
	KBDV110236
	KBDV110248
<p>BLANK DIE 2" 2-1/2"</p> <p>Can be machined for custom applications.</p>	KBDB000012
	KBDB000024
	KBDB000036
	KBDB000048

30 Degree Dies

Dimensions	Part No.-Lgth.
<p>1/4" 1-3/4" TYP</p> <p>Up to 22ga. M.S.</p>	KBDA010412
	KBDA010424
	KBDA010436
	KBDA010448
<p>3/8"</p> <p>Up to 18ga. M.S.</p>	KBDA030812
	KBDA030824
	KBDA030836
	KBDA030848
<p>1/2" 1-7/8" TYP</p> <p>Up to 10ga. M.S.</p>	KBDA010212
	KBDA010224
	KBDA010236
	KBDA010248
<p>5/8"</p> <p>Up to 14ga. M.S.</p>	KBDA050812
	KBDA050812
	KBDA050812
	KBDA050812
	KBDA050812

K•Prene® urethane female dies are designed for production and will not leave die marks! They feature tremendous load-bearing capacity and excellent resistance to abrasion. These are manufactured in 48" lengths and can be butted together as needed. They are lightweight, easy to handle, stocked for immediate delivery and may be shipped via UPS.

- Standard in **75D** durometer.
- Desired opening equals 8X the material thickness of Mild Steel.
- Stainless Steel requires 10X the material thickness for die opening.
- NOT recommended for coining.
- Comparable to steel dies when used for air bending.
- Larger unique sizes are available.

• **Pricing available online:**
www.acrotechinc.com

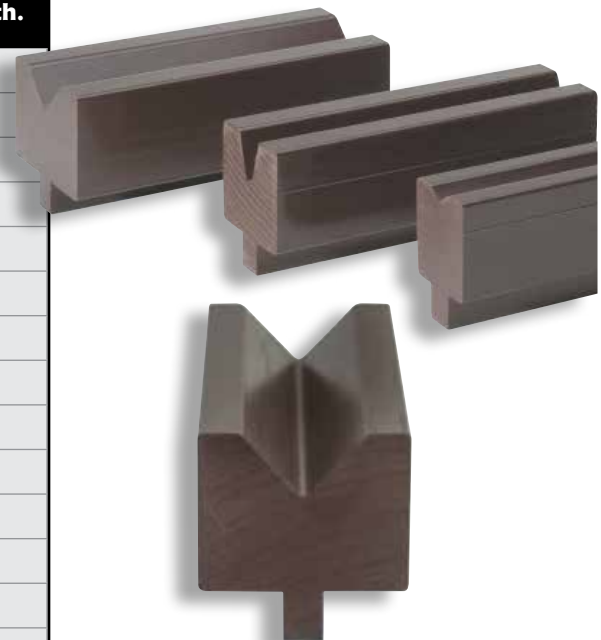

Call us for samples!
1-800-345-0583

Note: All dies have standard 1/2" x 5/8" tang.

acroform™ inserts



For a quick and effective way to avoid die marks on stainless steel, pre-painted material, etc. simply position these 1" or 2" inserts in corresponding 90° bottom dies! The K•Prene® insert will conform to a variety of punch tips. In addition to eliminating the secondary procedure expense of removing die marks, your die will now act like a universal bottom die.

- The forming of expanded metal or mesh is simplified, as cracking is reduced and often eliminated.
- This product is available in **95A** durometer.
- Also available in softer durometers.
- Economical
- Fitted in seconds
- Removed in seconds
- Forms many bends
- No marking
- Accurate forming
- Sharper bends
- Reduced springback
- Uses existing female dies
- No matted dies required
- Eliminates wear
- Worn out dies become precision dies

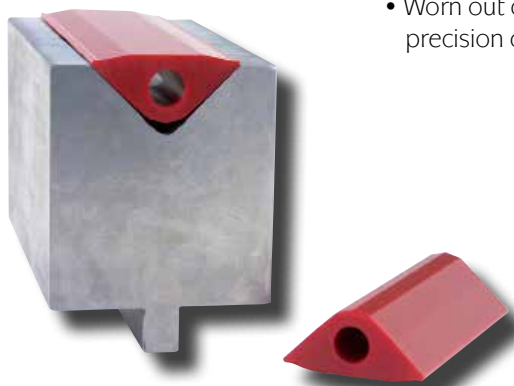

Dimensions	Part No. - Lgth.
<p>1" Insert 1/2" H</p>	KAF16100012
	KAF16100024
	KAF16100036
	KAF16100048
<p>2" Insert 1" H</p>	KAF16200012
	KAF16200024
	KAF16200036
	KAF16200048
<p>2" Insert 1" H</p>	KAF16200012WCH
	KAF16200024WCH
	KAF16200036WCH
	KAF16200048WCH

View website for pricing:
www.acrotechinc.com

Dimensions	Part No.
Double-faced Clamping Tape 1" x 36 yds	KPT136

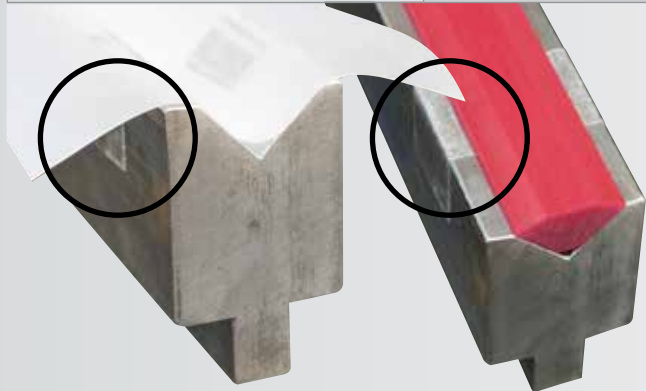

double-faced clamping tape

This double-faced tape securely holds Acroform™ and Acro-Hyde™ in place. It eliminates the need for fixtures, clamping devices, bolts, etc.



Urethane Parts for Piranha® Ironworkers

Piranha® is a registered trademark of Mega Manufacturing, Inc. Mega Manufacturing, Inc. is not affiliated in any way with Acrotech Inc.



Durometer/Color	Piranha Part No.	Acrotech Part No.	Piranha® Ironworker Model Numbers												
			P-2	P-36	P-40	P-50 (P-3)	P-50	P-70	P-90	P-110	P-120	P-140	PIII-65/88	PII-110	PII-140
PUNCH ASSEMBLY : STRIPPER BLOCK															
90A-Blue & 95A-Red	0330403	PIR-P35/P50 & 500-0218	✓	✓	✓	✓	✓								
90A-Blue & 95A-Red	0340403	PIR-P70/P90 & 500-0182						✓	✓	✓	✓	✓			
SHEAR HOLD-DOWN ASSEMBLY : SHEAR URETHANE															
95A-Black	0330207	500-5470					✓								
95A-Black	0340207	500-9975							✓	✓	✓	✓			✓
95A-Black	0350207	501-0087						✓						✓	
95A-Black	0376227	501-0089										✓			
SHEAR HOLD-DOWN ASSEMBLY : ANGLE URETHANE															
95A-Black	03302081	500-7043					✓								
95A-Black	0340208	500-9974							✓	✓	✓	✓			✓
95A-Black	0350208	501-0090						✓						✓	
95A-Black	0376228	501-0091										✓			
SHEAR HOLD-DOWN ASSEMBLY : ROUND BAR URETHANE															
95A-Black	0330209	501-0092					✓					✓			
95A-Black	0340209	501-0093						✓	✓	✓	✓	✓		✓	✓

strippers- Wiedemann®

- For Wiedemann® W-20, W-30, W45, & Centrum® Models
- Standard in **90A** Durometer - other Durometers available.

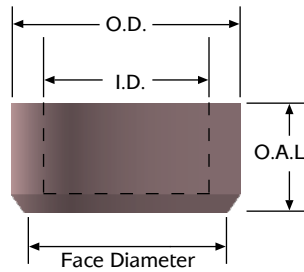

112 Style Tooling

Stn.	Shape	Face Dia. (inches)	I.D. (inches)	O.D. (inches)	Lgth. (inches)	Part No. (90A)
B	Std	1-5/32	31/32	2	1-27/32	500-1453
C	Std	1-23/32	1-15/32	2-1/16	2-1/16	500-1455
D	Std	2-7/32	1-31/32	3	1-1/2	500-1456
D	1" sq.*	2-7/32	1-31/32	3	1-1/2	500-1520
D	Rect**	2-7/32	1-31/32	3	1-1/2	500-1511
E	Std	2-29/32	3-3/32	4-9/32	1-1/2	500-1457
E	Rect**	2-29/32	3-3/32	4-9/32	1-1/2	500-1459
F	Std	3-11/16	3-3/32	4-9/32	1-1/2	500-1462
F	2" sq.*	3-11/16	3-3/32	4-9/32	1-1/2	500-1467
F	Rect**	3/11/16	3-3/32	4-9/32	1-1/2	500-1526
G	Std	4-13/16	3-15/32	4-25/32	1-1/2	500-1463
G	Rect**	4-13/16	3-15/32	4-25/32	1-1/2	500-1527
K	Std	* 1" and 2" squares only				
K	Rect**	** 1/2" and narrower rectangles only				

114 Style Tooling

Stn.	Shape	Face Dia. (inches)	I.D. (inches)	O.D. (inches)	Lgth. (inches)	Part No. (90A)
B	Std	1-1/8	1-1/16	1-31/3	2.362	500-1342
C	Std	1-23/32	1-3/4	2-1/2	2-5/16	500-1344
D	Std	2-7/32	1-31/32	3	2-3/32	500-1351
D	1" sq.*	2-7/32	1-31/32	3	2-3/32	500-1379
D	Rect**	2-7/32	1-31/32	3	2-3/32	500-1421
E	Std	2-29/32	2-31/32	4	2-3/32	500-1354
E	Rect**	2-29/32	2-31/32	4	2-3/32	500-1448
F	Std	3-9/32	2-31/32	4	2-3/32	500-1355
F	2" sq.*	3-9/32	2-31/32	4	2-3/32	500-1531
F	Rect**	3-9/32	2-31/32	4	2-3/32	500-1530
G	Std	3-25/32	4-11/32	5-5/32	2-3/32	500-1359
G	2" sq.*	3-25/32	4-11/32	5-5/32	2-3/32	500-1426
G	Rect**	3-25/32	4-11/32	5-5/32	2-3/32	500-1528
H	Std	4-17/16	4-11/32	5-5/32	2-3/32	500-1360
H	Rect**	4-17/16	4-11/32	5-5/32	2-3/32	500-1452
J	Std	5-11/32	4-23/32	5-13/16	2-3/32	500-1375
J	Rect**	5-11/32	4-23/32	5-13/16	2-3/32	500-1431
K	Std	6-5/8	5-23/32	6-5/8	2-3/32	500-1534
K	Rect**	6-5/8	5-23/32	6-5/8	2-3/32	500-1535

surstrip™ punch strippers



- Longer Tool Life: These strippers generate high holding pressure and strip the blank cleanly from the punch, resulting in an optimum working condition for the punch and longer effective work life.
- Easy To Use: Simply push stripper onto punch shank (I.D. is slightly undersized to grip punch). First stroke of press forces punch tip through stripper bottom.
- Very high load-bearing capacities.
- Safer than steel springs, since they do not fragmentize.
- Ideal for punching odd shaped holes.
- **Pricing available online:** www.acrotechinc.com

View website for more information:
www.acrotechinc.com

SurStrip™ Punch Strippers

I.D. (in.)	O.D. (in.)	Length (in.)	Part No.
3/16	11/16	1-1/4	KSS316114
		1-1/2	KSS316112
1/4	3/4	1-1/4	KSS014114
		1-1/2	KSS014112
		1-3/4	KSS014134
5/16	13/16	1-1/4	KSS516114
		1-1/2	KSS516112
		1-3/4	KSS516134
		2	KSS516200
3/8	7/8	1-1/4	KSS038114
		1-1/2	KSS038112
		1-3/4	KSS038134
		2	KSS038200
1/2	1	1-1/4	KSS012114
		1-1/2	KSS012112
		1-3/4	KSS012134
		2	KSS012200
	1-1/4	2-1/4	KSS012214
		1-3/4	KSS012134A
5/8	1-1/8	2	KSS012200A
		1-1/4	KSS058114
		1-1/2	KSS058112
		1-3/4	KSS058134
3/4	1-1/2	2	KSS058200
		1-3/4	KSS034134
		2	KSS034200
		2-1/4	KSS034214
		2-1/2	KSS034212
		2-3/4	KSS034234

Metric

I.D. (in.)	O.D. (in.)	Length (in.)	Part No.
7/8	1-3/4	1-3/4	KSS078134
		2	KSS078200
		2-1/4	KSS078214
		2-1/2	KSS078212
		2-3/4	KSS078234
1	2	1-3/4	KSS100134
		2	KSS100200
		2-1/4	KSS100214
		2-1/2	KSS100212
		2-3/4	KSS100234
1-1/4	2-1/2	2	KSS114200
		2-1/4	KSS114214
		2-1/2	KSS114212
		2-3/4	KSS114234
		3	KSS114300
1-1/2	2-3/4	2	KSS112200
		2-1/4	KSS112214
		2-1/2	KSS112212
		2-3/4	KSS112234
		3	KSS112300
2	3	2-1/4	KSS200214A
	3-1/4	2-1/4	KSS200214
3	4	2-1/4	KSS300214A
	4-1/2	2-1/4	KSS300214

I.D. (mm)	O.D. (mm)	Lgth. (mm)	Part No.
6	19	45	MSS006045
6	19	53	MSS006053
6	19	71	MSS006071
8	21	45	MSS08045
8	21	53	MSS008053
8	21	71	MSS008071
10	23	45	MSS010045
10	23	53	MSS010053
10	23	56	MSS010056
10	23	71	MSS010071
13	26	45	MSS013045
13	26	53	MSS013053
13	26	56	MSS013056
13	26	71	MSS013071
16	30	45	MSS016045
16	30	53	MSS016053
16	30	56	MSS016056
16	30	71	MSS016071
20	38	45	MSS020045
20	38	53	MSS020053
20	38	71	MSS020071
25	50	45	MSS025045
25	50	53	MSS025053
25	50	71	MSS025071
32	60	45	MSS032045

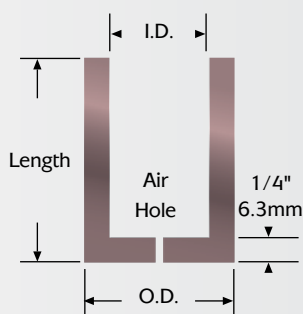

Standard Sizes-

- Strippers with I.D. of 3/16", 1/4" and 5/16" have 1/16" dia. air holes
- All others have 1/8" air holes

Metric Sizes-

- Metric and custom are available.
- **Call for pricing!**



K•Prene® tubes/springs

Available in **95A** durometer, tubes/springs are useful in applications where vibration, corrosion and magnetism prevent the use of steel springs. Also, urethane springs have proven to be safest, most efficient and reliable compression material for punching, stamping and drawing dies.

The K•Prene® urethane Tube/Spring material is a polyether-elastomer that reacts similarly to an incompressible fluid. The volume of material moved by compression is displaced laterally in the form of bulging sides. An approximate change in the diameter of our K•Prene® urethane Tubes/Springs can be made by increasing the diameter by the same amount of compression.

- Abrasion resistance
- They do not fragmentize
- High load-carrying capability
- Protection from marring/galling
- Longer life
- Oil and solvent resistance
- Low noise
- Vibration damping and shock absorbance
- 100% load-bearing surface
- Effectiveness between -30° F. and 180° F.

Visit www.acrotechinc.com for K-Prene® Tubes & Springs pricing

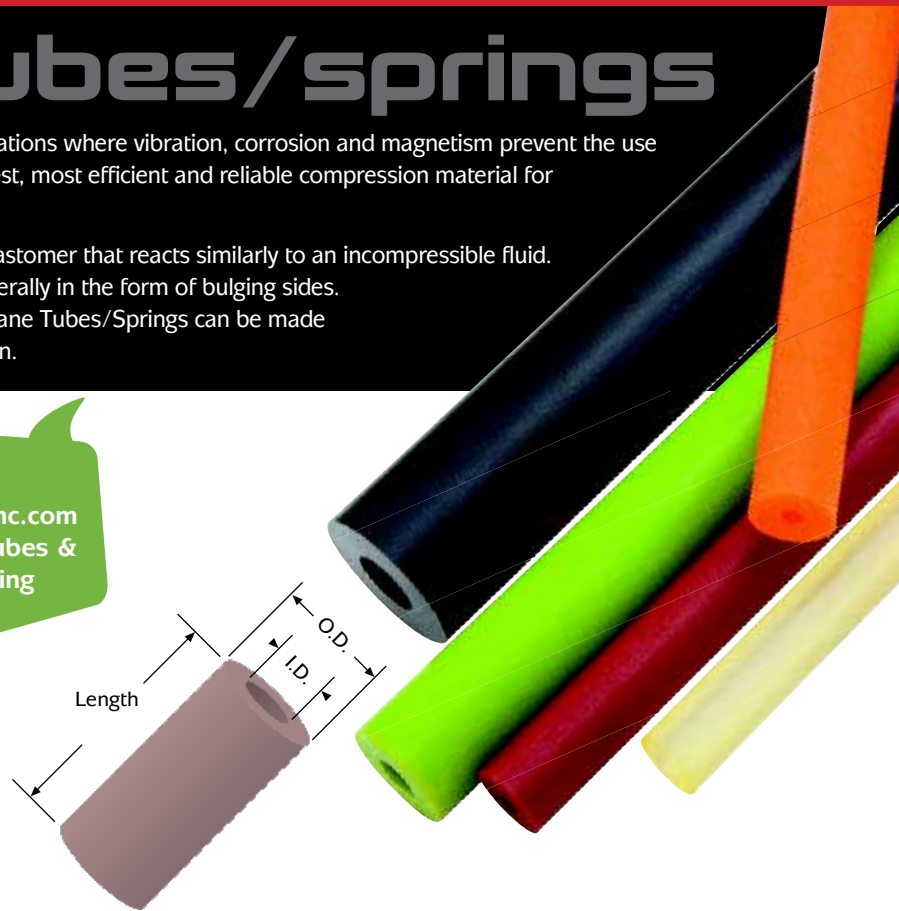

Fits Punch Body			
Diam (in.)	O.D. (in.)	Lgth. (in.)	Part No.
3/16	11/16 High Press	1-1/4	KPS0316H01104
		1-1/4	KPS0316H01102
		12	KPS0316H12000
1/4	3/4 High Press	1	KPS0104H01000
		1-1/4	KPS0104H01104
		1-1/2	KPS0104H01102
		1-3/4	KPS0104H01304
		12	KPS0104H12000
		7/8 Very High Press	1
	1-1/4	KPS0104V01104	
	1-1/2	KPS0104V01102	
	1-3/4	KPS0104V01304	
	12	KPS0104V12000	
5/16	13/16 High Press	1-1/4	KPS0516H01104
		1-1/2	KPS0516H01102
		1-3/4	KPS0516H01304
		2	KPS0516H02000
		12	KPS0516H12000

Fits Punch Body			
Diam (in.)	O.D. (in.)	Lgth. (in.)	Part No.
3/8	7/8 High Press	1	KPS0308H01000
		1-1/4	KPS0308H01104
		1-1/2	KPS0308H01102
		1-3/4	KPS0308H01304
		2	KPS0308H02000
		12	KPS0308H12000
	1 Very High Press	1	KPS0308V01000
		1-1/4	KPS0308V01104
		1-1/2	KPS0308V01102
		1-3/4	KPS0308V01304
		2	KPS0308V02000
		12	KPS0308V12000
	1-1/8 Ultra High Press	1	KPS0308U01000
		1-1/4	KPS0308U01104
		1-1/2	KPS0308U01102
1-3/4		KPS0308U01304	
2		KPS0308U02000	
12		KPS0308U12000	

Fits Punch Body			
Diam (in.)	O.D. (in.)	Lgth. (in.)	Part No.
1/2	1 High Press	1	KPS0102H01000
		1-1/4	KPS0102H01104
		1-1/2	KPS0102H01102
		1-3/4	KPS0102H01304
		2	KPS0102H02000
		24	KPS0102H24000
	1-1/8 Very High Press	1	KPS0102V01000
		1-1/4	KPS0102V01104
		1-1/2	KPS0102V01102
		1-3/4	KPS0102V01304
		2	KPS0102V02000
		24	KPS0102V24000
	1-1/4 Ultra High Press	1	KPS0102U01000
		1-1/4	KPS0102U01104
		1-1/2	KPS0102U01102
		1-3/4	KPS0102U01304
		2	KPS0102U02000
		24	KPS0102U24000

Fits Punch Body				
Diam (in.)	O.D. (in.)	Lgth. (in.)	Part No.	
5/8	1-1/8 High Press	1	KPS0508H01000	
		1-1/4	KPS0508H01104	
		1-1/2	KPS0508H01102	
		1-3/4	KPS0508H01304	
		2	KPS0508H02000	
		24	KPS0508H24000	
	1-1/4 Very High Press	1	KPS0508V01000	
		1-1/4	KPS0508V01104	
		1-1/2	KPS0508V01102	
		1-3/4	KPS0508V01304	
		2	KPS0508V02000	
		24	KPS0508V24000	
	1-3/8 Ultra High Press	1	KPS0508U01000	
		1-1/4	KPS0508U01104	
		1-1/2	KPS0508U01102	
		1-3/4	KPS0508U01304	
		2	KPS0508U02000	
		24	KPS0508U24000	
	3/4	1-3/8 High Press	1-1/4	KPS0304H01104
			1-1/2	KPS0304H01102
			1-3/4	KPS0304H01304
			2	KPS0304H02000
			2-1/4	KPS0304H02104
			2-1/2	KPS0304H02102
24			KPS0304H24000	
1-1/2 Very High Press			1-1/4	KPS0304V01104
		1-1/2	KPS0304V01102	
		1-3/4	KPS0304V01304	
		2	KPS0304V02000	
		2-1/4	KPS0304V02104	
		2-1/2	KPS0304V02102	
		2-3/4	KPS0304V02304	
		24	KPS0304V24000	
1-3/4 Ultra High Press		1-1/4	KPS0304U01104	
		1-1/2	KPS0304U01102	
		1-3/4	KPS0304U01304	
		2	KPS0304U02000	
		2-1/4	KPS0304U02104	
		2-1/2	KPS0304U02102	
		2-3/4	KPS0304U02304	
		24	KPS0304U24000	

Fits Punch Body				
Diam (in.)	O.D. (in.)	Lgth. (in.)	Part No.	
7/8	1-5/8 High Press	1-1/2	KPS0708H01102	
		1-3/4	KPS0708H01304	
		2	KPS0708H02000	
		2-1/4	KPS0708H02104	
		2-1/2	KPS0708H02102	
		2-3/4	KPS0708H02304	
		3	KPS0708H03000	
		24	KPS0708H24000	
		1-3/4	1-1/2	KPS0708V01102
			1-3/4	KPS0708V01304
			2	KPS0708V02000
			2-1/4	KPS0708V02104
	2-1/2		KPS0708V02102	
	2-3/4		KPS0708V02304	
	2	3	KPS0708V03000	
		24	KPS0708V24000	
		1-1/2	KPS0708U01102	
		1-3/4	KPS0708U01304	
		2	KPS0708U02000	
		2-1/4	KPS0708U02104	
	2-1/2	KPS0708U02102		
	2-3/4	KPS0708U02304		
	3	KPS0708U03000		
	24	KPS0708U24000		

Fits Punch Body					
Diam (in.)	O.D. (in.)	Lgth. (in.)	Part No.		
1	1-3/4 High Press	1-1/4	KPS1000H01104		
		1-1/2	KPS1000H01102		
		1-3/4	KPS1000H01304		
		2	KPS1000H02000		
		2-1/4	KPS1000H02104		
		2-1/2	KPS1000H02102		
		2-3/4	KPS1000H02304		
		24	KPS1000H24000		
		2 Very High Press	1-1/4	KPS1000V01104	
			1-1/2	KPS1000V01102	
			1-3/4	KPS1000V01304	
			2	KPS1000V02000	
	2-1/4		KPS1000V02104		
	2-1/2		KPS1000V02102		
	2-3/4		KPS1000V02304		
	3		KPS1000V03000		
	4		KPS1000V04000		
	24		KPS1000V24000		
	2-1/2 Ultra High Press		1-1/4	KPS1000U01104	
			1-1/2	KPS1000U01102	
		1-3/4	KPS1000U01304		
		2	KPS1000U02000		
		2-1/4	KPS1000U02104		
		2-1/2	KPS1000U02102		
		2-3/4	KPS1000U02304		
		3	KPS1000U03000		
		4	KPS1000U04000		
		24	KPS1000U24000		
		1-1/4	2-1/2 High Press	2	KPS1104H02000
				2-1/4	KPS1104H02104
	2-1/2			KPS1104H02102	
	2-3/4			KPS1104H02340	
	3			KPS1104H03000	
	24			KPS1104H24000	
	1-1/2		2-3/4 High Press	2	KPS1102H02000
				2-1/4	KPS1102H02104
				2-1/2	KPS1102H02102
				2-3/4	KPS1102H02304
				3	KPS1102H03000
				24	KPS1102H24000

Visit www.acrotechinc.com for K-Prene® Tubes & Springs deflection values and competitive pricing



ROLL BENDING MACHINES

Acrotech machines best fit into an OEM type fabrication/ manufacturing facility where high volume, consistent parts are required at low cycle times.

Send us your material. We will roll a sample for you!

The Benefits of "One Pass" Two Roll Bending Machines

- Roll parts with a minimum of flat on the leading and trailing ends for easier welding and better looking parts.
- Increase production and lower costs because there is no preforming required.
- Roll perforated and other difficult materials without fluting or kinking. Roll prefinished materials (stainless, aluminum, prepaint, etc.) without damaging parts.
- Easy set up and operations with excellent repeatability and quick tooling changes.

Understanding Two Roll Principle

The two roll method is comprised of a steel top roll and urethane bottom roll. The steel roll is pushed into the urethane roll. The urethane roll under pressure will not compress but rather deflect around the steel roll. This is the same function as hydraulic fluid in a hydroforming process. Sheet metal is then inserted between the two rolls and the urethane forms or wraps the metal against the steel roll as it rotates forming a curved surface. The radius of the formed part is controlled by the radius of the steel roll and the natural spring-back of the material. Changing the radius of the steel roll will change the radius of the formed part.

Two Roll, Steel Urethane System:

Rotation of both rolls produces accurate curving and rolling of complete or partial cylinders in one pass!

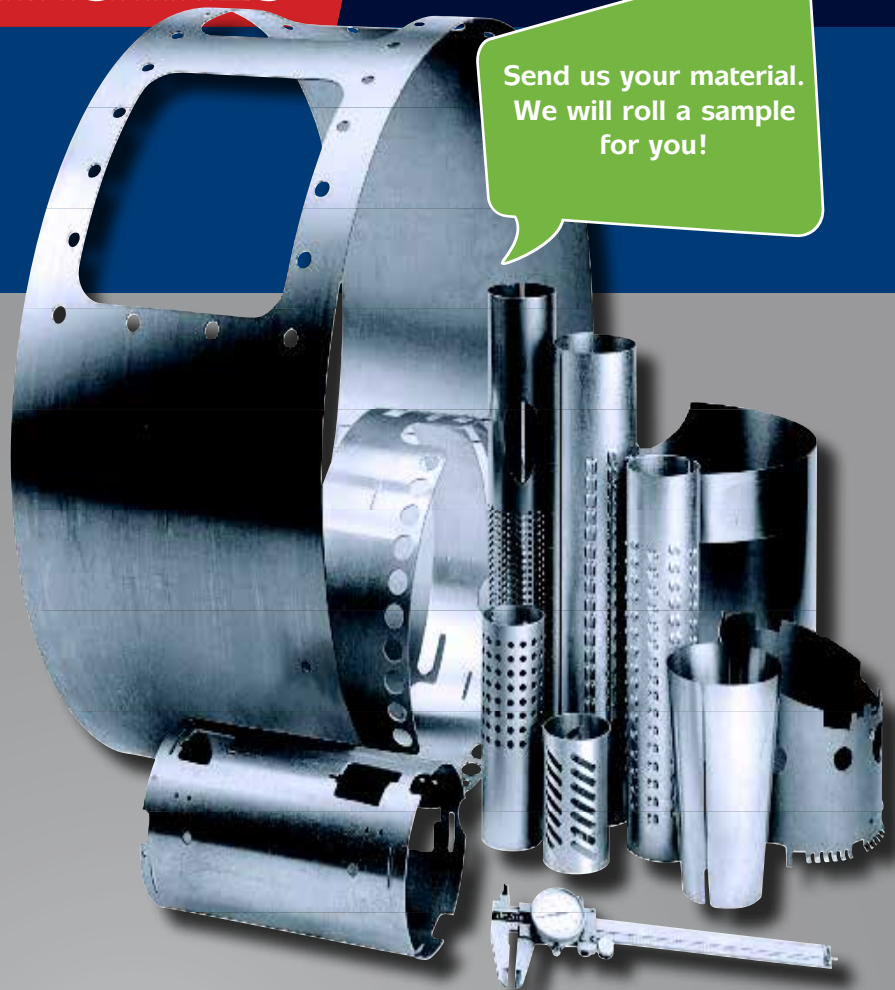
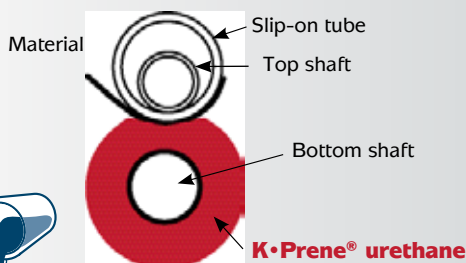

Some of the disadvantages of a Three Roll, Pinch-Type or Pyramid-Type system include:

- The work piece is not confined during the bending process, and several passes might be required with roll adjustments necessary after each pass. This is relatively slow and requires considerable skill on the operators' part.
- The ends of blanks must be pre-formed on other equipment (or cut off which means material waste).
- Flat areas may form between cutouts and perforations in a part, eliminating the possibility of making such openings while the piece part is flat, requiring more complex process.
- Fluting or kinking of material will occur especially in parts with cutouts and perforations.
- It is practically impossible to roll prefinished (polished, painted, enameled, etc.) material without the possibility of damaging finished surfaces (cracking and scratching).

Three Roll, Pinch-Type System:

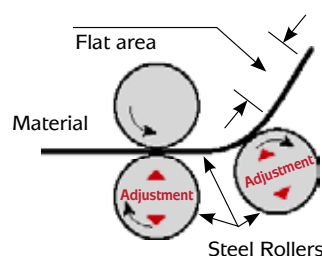

Three Roll, Pyramid-Type System:

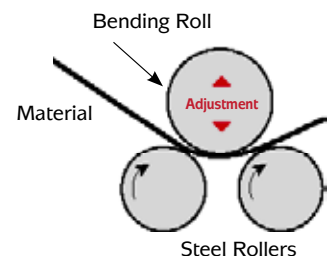

roll bending

Every model in Acrotech's unique line of Two Roll Bending Machines is designed and built for production and precision. These machines will roll a variety of materials and configurations into cylinders with virtually no flats on the ends!

models 1212, 1618 and 1824

Built to meet the demands of production involving small, light gauge parts. Pneumatic lock-up is standard on all models for increased productivity. 120V 1PH standard wiring simplifies installation. 220 or 440V 3PH wiring is also available.



model V-1006

The unique design of the cantilevered rolls mounted in a vertical position, allows the parts to simply drop from the machine at the end of the rolling cycle, greatly increasing productivity. Its short, sturdy rolls are ideally suited for narrow parts such as clamps, brake bands, hole saws, light fixtures, etc.



If you would like to see our machines in action, call us or check out the videos on our web site! www.acrotechinc.com



LD & HD models

Designed for the production of larger, heavier gauge parts. The drop arm and the lower roll are positioned pneumatically on all LD machines and hydraulically on the HD models. (See pages 32-33 for standard and optional accessories).

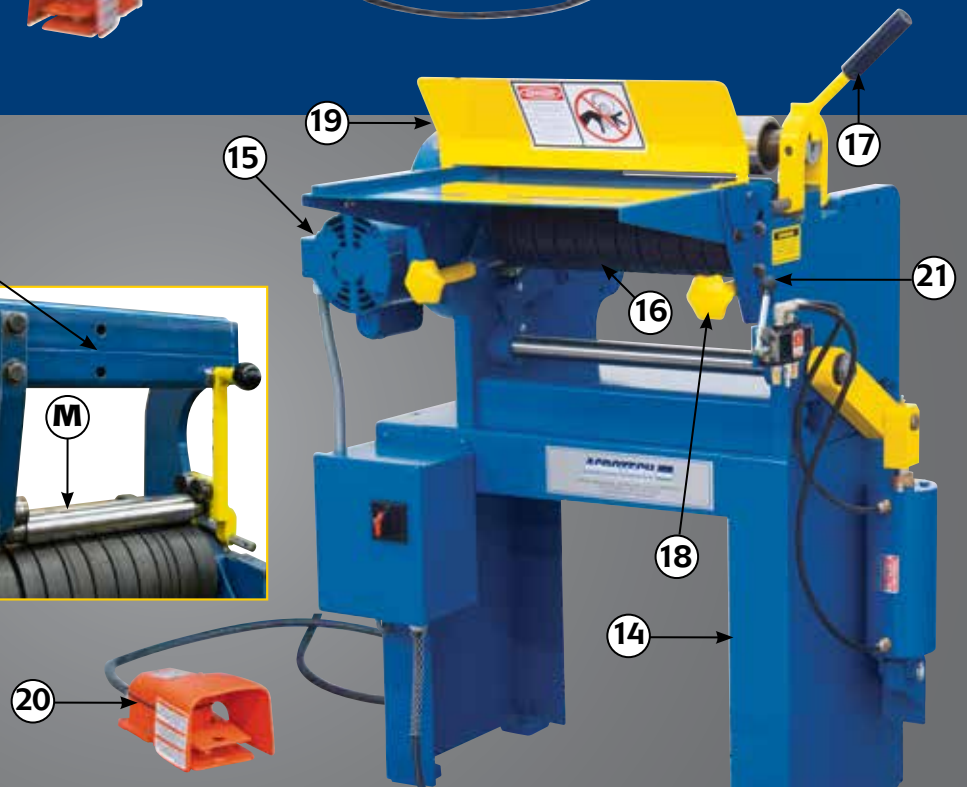
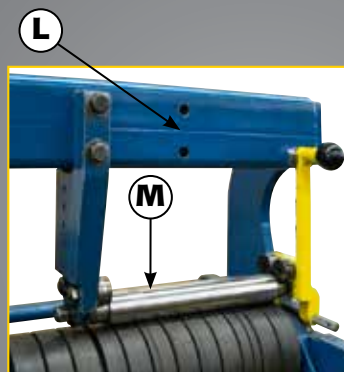
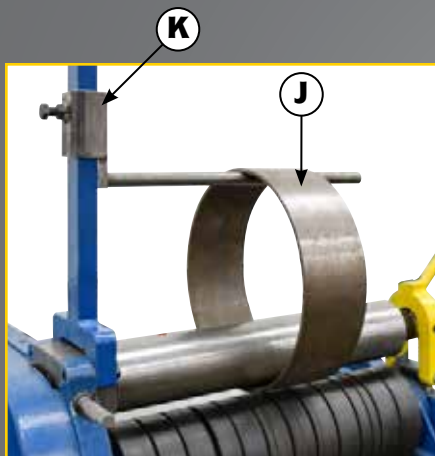
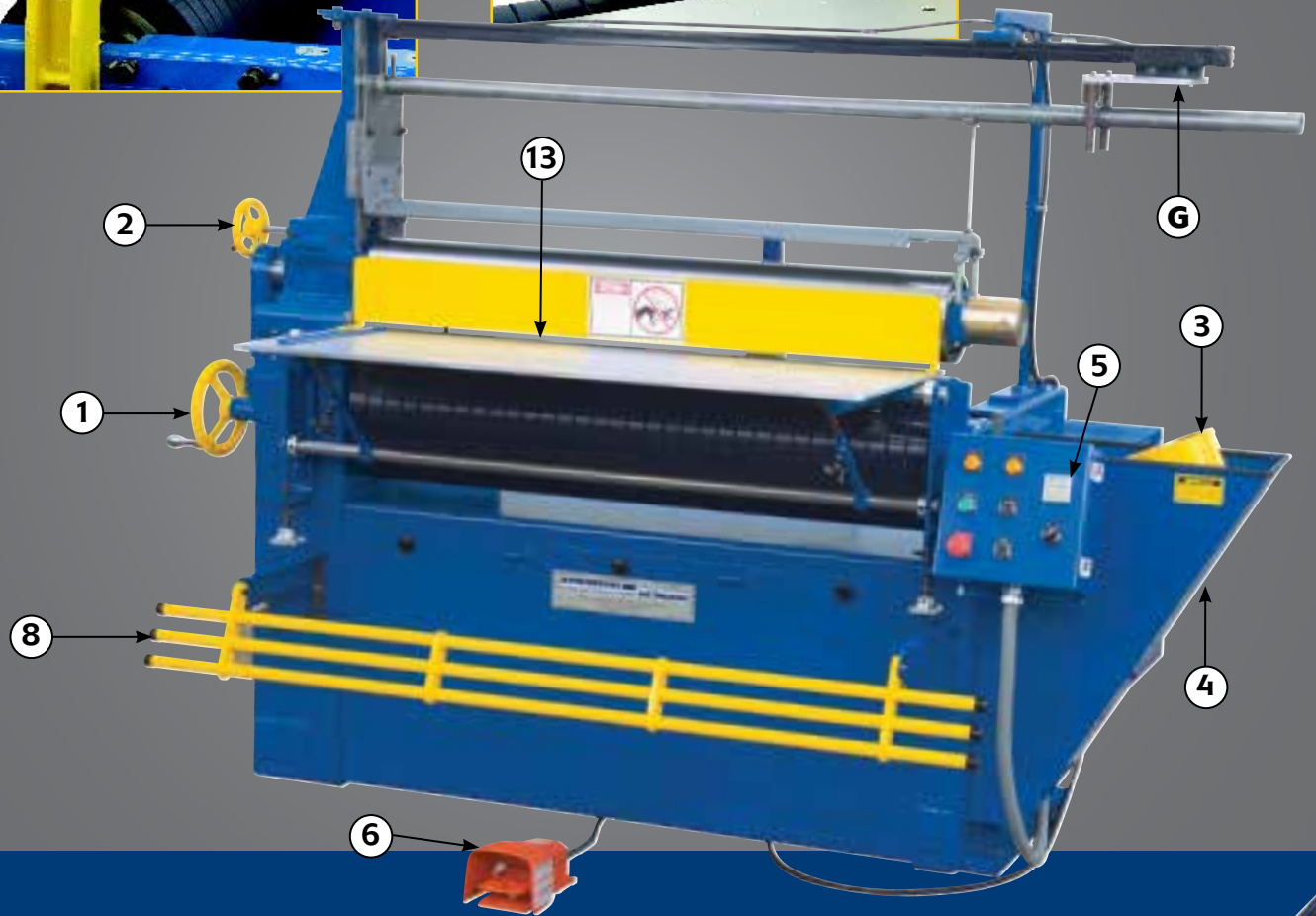
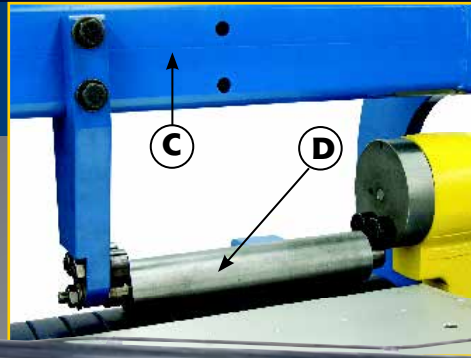
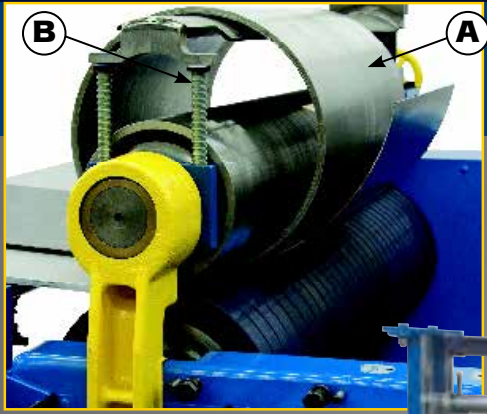

LD & HD models

Standard Equipment and Optional Accessories (See page 32 for specifications).

STANDARD EQUIPMENT

- ① **Roll Position Control** - single hand wheel provides quick parallel roll adjustment.
- ② **Rotating Counter**- indicates roll position in increments for repeat set up.
- ③ **Automatic Overarm** - Operates sequentially with K•Prene® roll raising and lowering. Automatically locks in place.
- ④ **Automatic Overarm Guard** - protects operator from moving overarm.
- ⑤ **Push-Button Control and Signal Light** - buttons control roll and overarm cycle. Light indicates when machine is ready for operation.
- ⑥ **Guarded Foot Switch** - leaves operator's hands free to feed material.
- ⑦ **Electricals** - are UL Compliant. (not shown)
- ⑧ **Safety Knee Bar** - provides additional safety for the operator. Tripping the bar stops roller rotation, lowers overarm, disengages rolls, and shuts off power simultaneously.
- ⑨ **Electro-Hydraulic Control (HD)** - for roll positioning and automatic overarm; all models have motor driven rolls. (not shown)
- ⑩ **Electro-Pneumatic Control (LD)** - for roll positioning and automatic overarm. (not shown)
- ⑪ **Bearings** - pre-packed and sealed in upper and lower roll assemblies. Each shaft is fitted with heavy-duty, self-aligning spherical roller bearings. (not shown)
- ⑫ **Anti-Deflection System** - prevents bowing in upper and lower roll assemblies, and provides for perfect cylindrical parts. (not shown)
- ⑬ **Feed Table** - Machine Supported; units are adjustable for height and feed angle and includes finger guard.

OPTIONAL ACCESSORIES

- Ⓐ **Tooling Slip on Tubes** - when the diameter required is larger than what the top shaft will produce, a Slip-On Tube is used. The tubes are developed per part size and increase the forming diameter capability of the top shaft. Quickly change the tube by simply slipping them on and off the top shaft as needed. A Slip-On Tube will be required for each specific part.
- Ⓑ **Slip-On Tube Support** - facilitates removal of finished piece-part. Adjustable in height, this accessory supports slip-on tubes to prevent pinching curved cylinders against lower roll when removing finished parts.
- Ⓒ **Small-OD Mounting Fixture** - required for rolling parts smaller in diameter than the standard top roll.
- Ⓓ **Small-OD Shaft Assembly** - available in various lengths and diameters for rolling material to a diameter smaller than standard top roll. Must be used in conjunction with Small-OD Mounting Fixture.
- Ⓔ **Auto Timer** - for controlling partial curvature of material 90°, U-bends, etc. Can be used in conjunction with Part Ejectors for automated rolling and part ejection. (not shown)
- Ⓕ **Reversing Control** - gives added flexibility for special jobs. (not shown)
- Ⓖ **Part Ejector** - for increased production, part ejectors and part feeders can be developed for most parts.
- Ⓗ **Motorized Roll Position Control** - speeds the set-up from one job to another. (not shown)
- Ⓘ **Additional Control Features** - can be custom built per customer requests. Features such as light curtains, special guarding...etc

1618, 1824 & 1212 models

Standard Equipment and Optional Accessories (See page 32 for specifications).

STANDARD EQUIPMENT

- ⑭ **Floor Stand** - provides ergonomic work positions for rolling blanks
- ⑮ **Motorized Roll Drive** - delivers necessary power to drive blank material through the forming coils
- ⑯ **Lower Roll Steel Core, with Grooved K•Prene® Urethane** - completes the forming operation with amply forming pressure
- ⑰ **Manual Quick-Release Lever** - allows rolled part removal with simple pivot downs
- ⑱ **Single-Lever Roll Engagement - Adjustable** - dual hand knobs provide quick roll adjustment
- ⑲ **Adjustable Feed Table with Finger Guard** - machine supported; adjustable for height and feed angle and includes a finger guard
- ⑳ **Guarded Electric Footswitch** - leaves operators hands free to feed material
- ㉑ **Pneumatic Lock-up** - with a hand actuated control lever to raise and lower urethane roll

OPTIONAL ACCESSORIES

- Ⓙ **Tooling Slip on Tubes** - when the diameter required is larger than what the top shaft will produce, a Slip-On Tube is used. The tubes are developed per part size and increase the forming diameter capability of the top shaft. Quickly change the tube by simply slipping them on and off the top shaft as needed. A Slip-On Tube will be required for each specific part.
- Ⓚ **Slip-On Tube Support** - facilitates removal of finished piece-part. Adjustable in height, this accessory supports slip-on tubes to prevent pinching curved cylinders against lower roll when removing finished parts.
- Ⓛ **Small-OD Mounting Fixture** - required for rolling parts smaller in diameter than the standard top roll.
- Ⓜ **Small-OD Shaft Assembly** - available in various lengths and diameters for rolling material to a diameter smaller than standard top roll. Must be used in conjunction with Small-OD Mounting Fixture. Permits rolling diameters as small as one inch.



roll bending machines

If you have large-volume needs for complete or partial cylinders with little or no flats on the ends, our machines will produce your parts quickly and cleanly. This includes polished materials containing large cutouts or perforations!

Roll Benders Specifications

Model Acrotech	Model Di-Acro®	Capacity mild steel		Working length of rolls		Diameter of top roll		Diameter of bottom roll		Rolling speed f.p.m.		Motor hp.
		Std.	Metric	Std.	Metric	Std.	Metric	Std.	Metric	Std.	Metric	
1212	-	12 ga.	2.7mm	12"	305mm	3-1/2"	88.9mm	9"	229mm	22	670.6CMPM	1.0
1618	M1835	16 ga.	1.5mm	18"	457mm	3-1/2"	88.9mm	6"	152mm	15	457.2CMPM	1.0
1824	-	18 ga.	1.2mm	24"	610mm	3-1/2"	88.9mm	6"	152mm	15	457.2CMPM	1.0
LD-1418	A1835	14 ga.	1.9mm	18"	457mm	3-1/2"	88.9mm	9"	229mm	23.2	707.1CMPM	1.5
LD-1118	A1840	11 ga.	3.1mm	18"	457mm	4"	102mm	9"	229mm	23.2	707.1CMPM	1.5
LD-1224	A2440	12 ga.	2.7mm	24"	610mm	4"	102mm	9"	229mm	23.2	707.1CMPM	1.5
LD-31618	A1850	3/16"	4.8mm	18"	457mm	5"	127mm	9"	229mm	19.8	603.5CMPM	3.0
LD-1024	A2450	10 ga.	3.4mm	24"	610mm	5"	127mm	9"	229mm	19.8	603.5CMPM	3.0
LD-1230	A3050	12 ga.	2.7mm	30"	762mm	5"	127mm	9"	229mm	23.2	707.1CMPM	1.5
HD-31624	B2460	3/16"	4.8mm	24"	610mm	6"	152mm	12"	305mm	16.0	487.7CMPM	5.0
HD-1030	B3060	10 ga.	3.4mm	30"	762mm	6"	152mm	12"	305mm	19.5	594.4CMPM	3.0
HD-1236	B3660	12 ga.	2.7mm	36"	914mm	6"	152mm	12"	305mm	19.5	594.4CMPM	3.0
HD-31630	B3070	3/16"	4.8mm	30"	762mm	7"	178mm	12"	305mm	16.0	487.7CMPM	5.0
HD-1036	B3670	10 ga.	3.4mm	36"	914mm	7"	178mm	12"	305mm	16.0	487.7CMPM	5.0
HD-1248	B4870	12 ga.	2.7mm	48"	1220mm	7"	178mm	12"	305mm	19.5	594.4CMPM	3.0
HD-31636	B3680	3/16"	4.8mm	36"	914mm	8"	203mm	12"	305mm	16.0	487.7CMPM	5.0
HD-1048	B4880	10 ga.	3.4mm	48"	1220mm	8"	203mm	12"	305mm	16.0	487.7CMPM	5.0
HD-1160	B6080	11 ga.	3.1mm	60"	1520mm	8"	203mm	12"	305mm	16.0	487.7CMPM	5.0
HD-1672	B7280	16 ga.	1.5mm	72"	1830mm	8"	203mm	12"	305mm	22.9	698.0CMPM	1.5
V-1006	V	10 ga.	3.4mm	6"	152mm	4"	102mm	8"	203mm	22.0	6.68CMPM	0.75

Uses for Acrotech roll bending machines

- Air tanks
- Architectural designs
- Catalytic converters
- Chemical or nuclear industrial containers
- Chimney flues
- Commercial vehicle panels
- Compressor casing for air conditioning
- Electric motor casings
- Exhaust systems
- Fan blades
- Fire extinguishers
- Gas or fluid tanks
- Hole saw blades
- Lighting fixtures
- Misc. ducting components
- Misc. rings and bands
- Motor and blower housings
- Name plates
- Pipe clamps
- Pressure vessels & tanks
- Sleeve bearings
- Tank heater elements
- Washing machine tubes
- Water heaters

Acrotech Roll Bender Warranty

Defective parts of a Roll Bending Machine manufactured by ACROTECH will be replaced or repaired at no charge for twelve (12) months following delivery to the original purchaser. Labor is included for the first 90 days. This warranty becomes void when products have not been used according to instructions furnished by ACROTECH nor does it cover any altered parts or unauthorized repairs. We cannot be responsible for the cost of repairs made or attempted outside of our factory. All other warranty claims are made FOB our plant, providing such item(s) is returned freight prepaid to our plant for examination.

This warranty does not apply to parts, components or systems not manufactured by ACROTECH.

These products are covered instead by the existing warranties, if any, of their manufacturers. Normal service items with a reasonable life expectancy of less than one year are warranted only to the extent of the reasonable life under normal use and service.

roll bending machine restoration

Acrotech will restore your used Di-Acro® / Acrotech Roll Bending Machines based on your requirements. We can overhaul every aspect of these machines in house to maximize your productivity while keeping costs down.



Before



After

roller recovering service

We are able to strip and recover your used roll bending urethane roller. These rollers can be recovered quickly to reduce production downtime. Purchasing a spare roller for your machine will eliminate any downtime while your other roller is being re-covered. In addition to the Acrotech and Di-Acro® machines we are also able to recover competitors rollers quickly and cost effectively.



Before

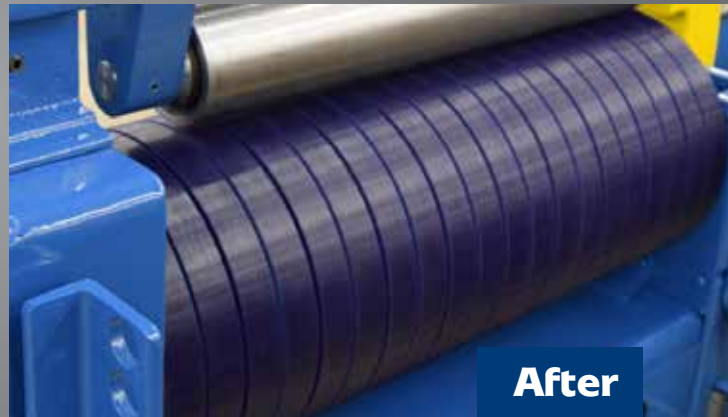

After

custom rolling available

Have a short run? Don't want to invest in a rolling machine yet? We will custom roll your material!



For ordering information visit: www.acrotechinc.com

Proudly made in Lake City, Minnesota – USA



Acrotech Terms, Conditions & Ordering Information

To Order

Indicate the part number (or the dimensions if there is no part number), along with the durometer and quantities desired for each part. Minimum orders required as noted.

Terms

Net due 30 days with approved credit, C.O.D., Visa, MasterCard, Discover and American Express.

Availability

Products are available in **K-400A, K-600A, K-800A, K-900A, K-950A** and **K-750D**, unless noted otherwise, and often can be shipped the same day as ordered.

Prices

Subject to change without notice. Cutting charges may be additional.

Return Policy

Please note, custom and non-standard orders shipped to customer specifications cannot be returned. A 20% re-stocking fee will be charged when returning stocked products.

To return defective goods for replacement or credit, Acrotech must be notified within 30 days of your receipt of the material. All requests for credited returns must be confirmed with Acrotech before the material is returned. Acrotech's liability for returned materials is limited to the cost of our materials.

Acrotech Warranty

Standard and custom urethane products will be warrantied for a period of 60 days after shipment from defects in material only. Misuse of the urethane material voids the warranty. Parts cannot be guaranteed to perform for specific applications without full disclosure of application prior to manufacturing by ACROTECH.

ACROTECH's liability under this warranty shall not exceed the amount paid for the product.

THIS IS ACROTECH'S SOLE WARRANTY IN LIEU OF ALL OTHER WARRANTIES, EXPRESS OR IMPLIED, WHICH ARE HEREBY EXCLUDED, INCLUDING IN PARTICULAR ALL WARRANTIES OF MERCHANTABILITY, FITNESS OR ANY LOSS, DAMAGE OR EXPENSES DIRECTLY OR INDIRECTLY RELATED TO THE USE OF ITS PRODUCT OR FROM ANY OTHER CAUSE OR FOR CONSEQUENTIAL DAMAGES INCLUDING, WITHOUT LIMITATION, LOSS OF TIME AND LOSS OF PRODUCTION.

IT IS EXPRESSLY UNDERSTOOD THAT ACROTECH IS NOT RESPONSIBLE FOR DAMAGE OR INJURY CAUSED TO OTHER PRODUCTS, MACHINERY, PROPERTY OR PERSONS BY REASON OF THE USE OF ITS PRODUCTS.

Urethane technical information and pricing of our products can be found online at: www.acrotechinc.com



Cat. 2017-1, effective 10/10/17



980 West Lakewood Avenue P.O. Box 466
Lake City, Minnesota 55041

Toll Free: 800-345-0583 • Fax: 651-345-3759

www.acrotechinc.com / email: acrotech@acrotechinc.com