

**Precision Punches,
Pilots,
Die Buttons,
& Retainers**

Versatile



Global leader in
providing fabrication
and stamping solutions

a MISUMI Group Company

www.daytonlamina.com

**Better
performance,
longer runs,
less downtime**



Versatile Precision Products

Product Applications

Versatile Punches, Pilots, Die Buttons, and Retainers are built to exact tolerances and concentricity to provide superior alignment, better performance, longer runs, and less downtime. Dayton Versatile products are considered "top-of-the-line" by regular users, and are mainstays in heavy industries with high-demand applications, such as automotive and major appliance manufacturing.

Versatile punches and die buttons provide three times better alignment than other major brands, thus assuring longer runs and better part performance. Versatile die buttons with tapered relief have no overhand and no step (unlike conventional counter-bored relief); provide positive slug control; and never fail due to lack of support of the cutting edge.

Dayton's Versatile precision product line includes: *Jektole® Punches (slug ejection punches); Regular Punches; Regular Pilots; Positive Pick-Up Pilots; Compact Positive Pick-Up Pilots; Straight and Blank Punches; Clospace Punches; Die Buttons; Retainers; Guide Bushings; and others, including Quill Bushings, Micro Guides, Misfeed Detectors, and Locking Devices.* Standard sizes and standard alterations are shown in this catalog within individual product sections.

Dayton Slug Control is a guaranteed method for reducing the risk of pulling slugs to the die surface during withdrawal of the punch. A series of grooves is designed inside the die buttons (see drawing). There, the slugs are trapped until they fall freely through the relief. The use of Dayton Slug Control has no effect on hole size, and will not require any changes in current regrind practices.

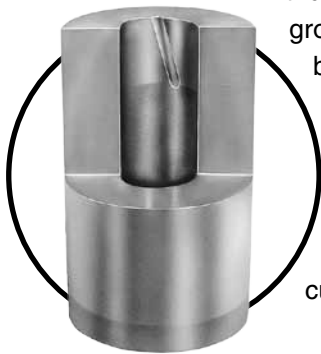

Ordering Information

Each page contains detailed instructions on how to order specific Dayton Versatile products. Individual drawings show product shape, dimensions, tolerances, and concentricity. When ordering, you are asked to specify quantity, type, shank and length codes (for example), and other applicable data.

In the example below, the type specified is "VPR." "V" stands for Versatile, "P" stands for punch, and "R" stands for rectangle. 37 is the press-fit diameter, which is coded by the first two digits of the decimal equivalent (.375"). 1223 is the shank length, which is coded by inches and quarter-inches (one inch and two quarters). 23 is the overall length, coded by inches and quarter-inches. Finally, P.1875 and W.1325 represent the point or hole size dimensions.

HOW TO ORDER

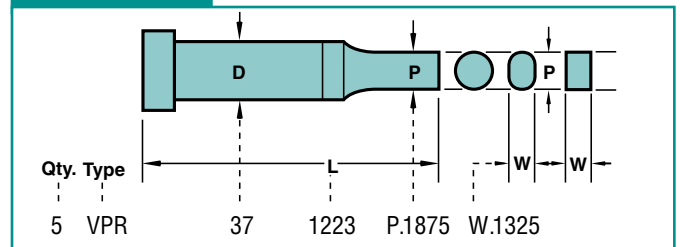

Standard Alterations

Punches, pilots, and die buttons are available in sizes other than those listed in the catalog.

When ordering, you are asked to specify different designations for various non-standard dimensions. For example, if the P and W dimensions are outside the standard range, an "X" is placed in front of the P or W dimension, e.g., "XP" and/or "XW." If the point length is other than standard, designate "XB" for the point length. See the foldout tabs in the individual product sections for these and other special order designations.

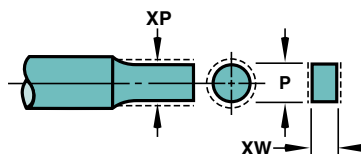

Contents

Punches

Standard Shapes

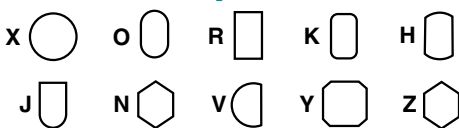

VJ_ Jektol[®]



VP_ Regular



VPT Pilots



VPA Pilots



VUAC/VPAC Pilots

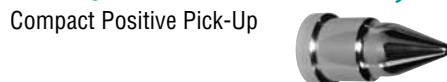

VJB/VPB Blanks



VYX/VUX Straight



CloSPACE

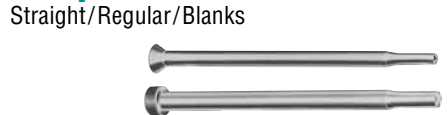

VJ_/VP_ Extended Range



Die Buttons

VN_/VR_ Die Buttons



KD_/KH_ EDM Button Blanks

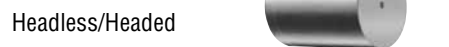

Retainers

VRP Retainers



VRT/VRTS Retainers



Bushings/Guides

VG/VF/VE Guide Bushings



Bushings/Guides (cont'd)

MEX/MFX/MGX Micro Guides



MDX/MHX Micro Buttons

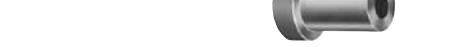

VQX/VFQ Quill Bushings/Guides



Miscellaneous/Other

Classified Shapes

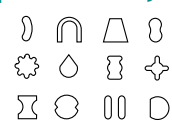

Shear Angles

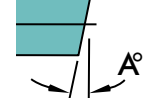

Locking Devices

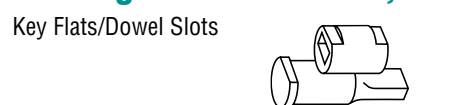

Form Shapes

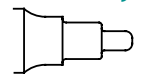

Jektol[®] Data

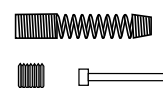

Product Designation

Each page contains detailed instructions on how to order specific Dayton Versatile products. In addition, use the following chart to define the product as a part number.

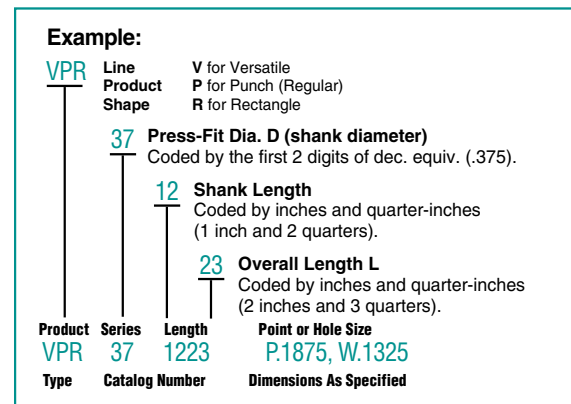

Diameter (D) is shown on the order as a two- or three-digit code. To convert the shank diameter to the appropriate code, use the following chart.

Code	D	Code	D	Code	D
12	.1250	50	.5000	150	1.5000
18	.1875	62	.6250	175	1.7500
25	.2500	75	.7500	200	2.0000
31	.3125	87	.8750	225	2.2500
37	.3750	100	1.0000	250	2.5000
43	.4375	125	1.2500		

Classified Shapes

Classified shapes (83 common shapes, no detailing required) are available on all punches, solid die buttons, and guide bushings as indicated in this catalog. See pp. 22, 23 for more information and special instructions. Also, see individual product pages and pp. 30, 31 for additional information on orientation and views.

Clearance

Normal grinding methods produce:

① .007 max fillet on the punch — matching corner shape on the die button.

② .007 max fillet on the die button — matching corner shape on the punch.

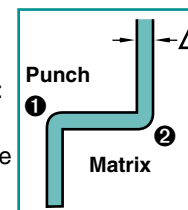

Compact Positive Pick-Up Pilots

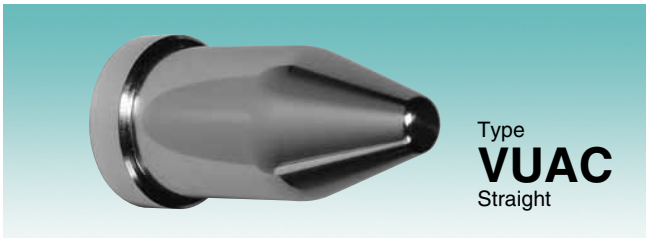

Material
Steel: A2, M2 (RC 60-63), PS (RC 63-65)

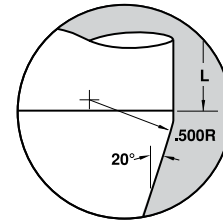
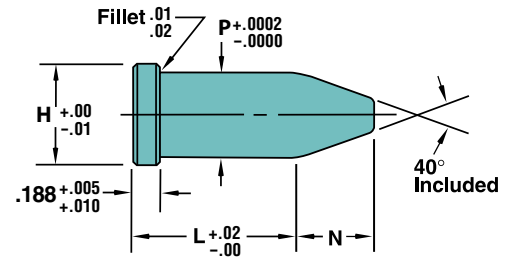

Type	Head H	Range P	N	*L													
				.625	.750	.875	1.00	1.125	1.250	1.375							
VUAC Straight	.375	.1865 - .2500	.25	62													
	.438	.2501 - .3130	.31														
	.500	.3131 - .3750	.37														
	.562	.3751 - .4380	.43														
	.625	.4381 - .5000	.50														
	.750	.5001 - .6250	.62									75	87	100	112	125	137
	.875	.6251 - .7500	.75														
	1.000	.7501 - .8750	.87														
	1.125	.8751 - 1.0000	1.00														

*Any length is available within catalog range. Specify "XL" and length.

HOW TO ORDER

Specify:	Qty.	Type	D Code	L	P	Alt.	Steel
Example:	25	VUAC	—	75	.4380	XL.695	A2
	11	VPAC	62	100	.6200	—	A2



Standard Alterations

Versatile compact positive pick-up pilots are available in sizes other than those shown in the charts on pp. 12, 13.

When ordering, you are asked to specify different designations for various non-standard dimensions.

For example, if the P dimension is outside the standard range, an "X" is placed in front of the P dimension, e.g. "XP." If the L₁ (VPAC only) is other than standard, designate "XBR" as the variable length. Also see "Standard Alterations" on the front of the pullout tab in this section for other special order designators.

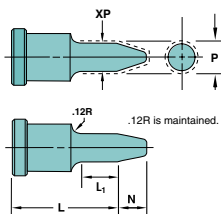

XP P Dimension Smaller than Standard

XBR L₁ Longer than Standard

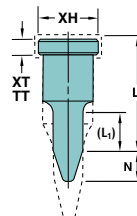

XL "L" Shortened
Stock removal from point end. L₁ length is maintained.

XT Thinner Head than Standard
Stock removal from head end which shortens overall length.

TT Precision Head Thickness
Same as XT except head thickness tolerance is held to ±.0005.

XH Reduced Head Diameter
Minimum head diameter equals H +.000 - .001.

Compact Positive Pick-Up Pilots



Material
Steel: A2, M2 (RC 60-63), PS (RC 63-65)

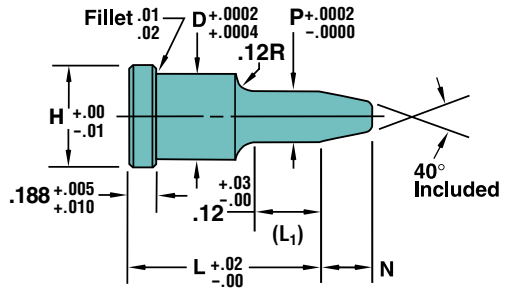

P to D .0003 ©

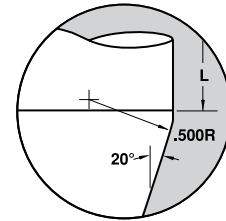

Type	Shank D	Code	Head H	Min. XP	Range P	*N	Pn	**L						
								.625	.750	.875	1.00	1.125	1.250	1.375
VPAC Pointed	.2500	25	.375	.092	.1500 - .2499	.25	.1432	62	75	87	100	112	125	137
	.3125	31	.438	.092	.1870 - .3124	.31	.1883							
	.3750	37	.500	.092	.2250 - .3749	.37	.2342							
	.4375	43	.562	.092	.2650 - .4374	.43	.2793							
	.5000	50	.625	.124	.3000 - .4999	.50	.3252							
	.6250	62	.750	.234	.3750 - .6249	.62	.4162							
	.7500	75	.875	.299	.4500 - .7499	.75	.5072							
	.8750	87	1.000	.349	.5250 - .8749	.87	.5982							
	1.0000	100	1.125	.399	.6000 - .9999	1.00	.6892							

*N = [(P - .057) / .728] + .132 when "P" dimension is less than "Pn" shown in chart.

**Any length is available within catalog range. Specify "XL" and length. The L₁.12 is maintained. Because L₁.12 is standard, use alteration code "XBR" for different length (0.060 min.).

Features/Benefits

Dayton Versatile Compact Positive Pick-Up Pilots—mounted in a guided stripper—provide exceptional resistance to lateral deflection. A typical longer pilot may have several inches of exposed, unsupported surface. As bending or forming takes place, this lateral deflection can create excessive force on the pilot. Sometimes, the strength of the pilot—as well as the function of the other die set components—can be compromised.

Dayton Compact Pilots provide virtually no unsupported surface that is susceptible to sideways movement, stress, or wear. Pilots always maintain the proper extension, and there is no need to move or adjust the pilot during grinding.

Dayton Compact Pilots are rigid during use; last longer; and are ideally suited for high-demand applications.

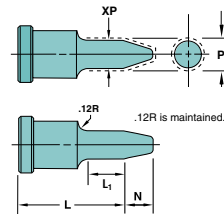

XP P Dimension Smaller than Standard

XBR L₁ Longer than Standard

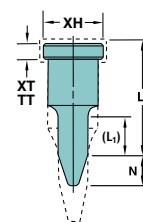

XL "L" Shortened
Stock removal from point end. L₁ length is maintained.

XT Thinner Head than Standard
Stock removal from head end which shortens overall length.

TT Precision Head Thickness
Same as XT except head thickness tolerance is held to ±.0005.

XH Reduced Head Diameter
Minimum head diameter equals H + .000 - .001.

XD Reduced Shank Diameter (VPAC only)
Head Diameter does not change with body diameter.

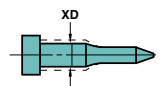

Shank Dia.	25	31	37	43	50	62	75	87	100
Min. XD	.188	.251	.313	.376	.438	.562	.688	.813	.938

Punch Blanks

Jektole® & Regular

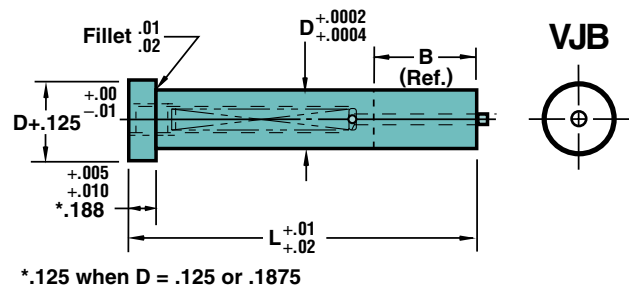
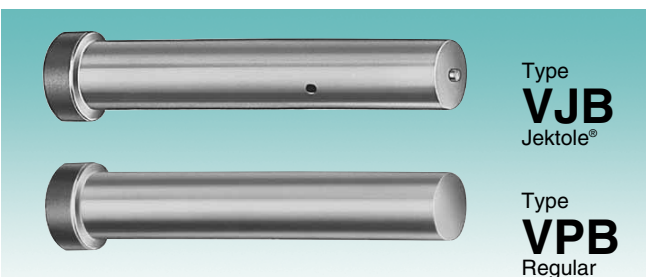

Punch Blanks

Jektole® & Regular

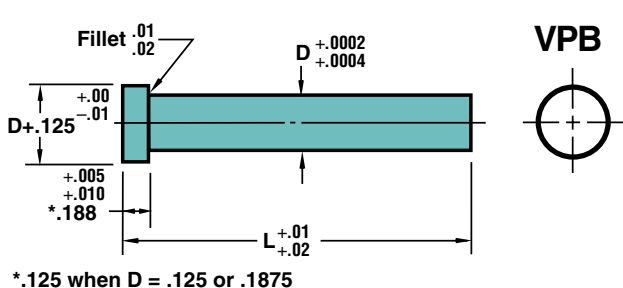

Type	Shank D	Code	Point Lgth. B	L																Code	L								Jektole® Group								
				1.25	1.50	1.75	2.00	2.25	2.50	2.75	3.00	3.25	3.50	3.75	4.00	4.25	4.50	4.75	5.00		5.25	5.50	5.75	6.00	6.25	6.50	6.75	7.00									
VJB	.1875	18	.50	0311	1012	1113	1220	1321	2022	2123	2230	2331	3032	3133	3240													18								J2	
	.2500	25																											25							J3	
	.3125	31																											31	5052	5153	5260	5361	6062			J4
	.3750	37																											37							J6	
	.4375	43	.75		0312	1013	1120	1221	1322	2023	2130	2231	2332	3033	3140														43							J6	
	.5000	50																											50	4352	5053	5160	5261	5362			J6
	.6250	62																											62								J9
	.7500	75																											75								J9
	.8750	87																										87								J9	
	1.0000	100																										100								J9	
	VJB	.1875	18	1.00			0313	1020	1121	1222	1323	2030	2131	2232	2333	3040													18								J2
		.2500	25																											25							
.3125		31																											31								J4
.3750		37																											37								J6
.4375		43				0320	1021	1122	1223	1330	2031	2132	2233	2340														43								J6	
.5000		50																										50	4252	4353	5060	5162	5262			J6	
.6250		62																										62								J9	
.7500		75																										75								J9	
.8750		87																										87								J9	
1.0000		100																										100								J9	
VPB		.1250	12	N/A	125	150	175	200	225	250	275	300	325	350	375	400													12								N/A
		.1875	18																											18							
	.2500	25																											25								
	.3125	31																											31								
	.3750	37																											37								
	.4375	43																											43								
	.5000	50					0321	1022	1123	1230	1331	2032	2133	2240	2341	3042	3143	3250	3351										50	4052	4153	4260	4361	5062			
	.6250	62																											62								
	.7500	75																											75								
	.8750	87																											87								
	1.0000	100																											100								

**See p.32 for additional information.

Standard Alterations

Punch Blanks

Material
Steel: A2, M2, PS4 (RC 60-63), PS (RC 63-65)
All heads are drawn to RC 40-55.

Features/Benefits

Dayton Punch Blanks are an ideal cost-effective alternative in applications where Dayton standard shape configurations or our classified shapes do not meet customer requirements. Blanks—available in a full range of standard lengths from 1.25" to 7.00"—can be custom-ground to meet virtually any customer requirement.

HOW TO ORDER

Specify:	Qty.	Type	D Code	L	Steel
Example:	4	VJB	50	1020	A2
	3	VPB	37	200	M2



Surface Coatings & Treatments

Some catalog products can be coated to increase hardness, reduce galling, and improve wear and/or corrosion resistance.

DayTride® (XN)—a low-cost surface application that treats all exposed surfaces. Ideal for punches and die buttons. Provides high dimensional stability. Approx. hardness: RC65-73.

DayTiN® (XNT)—applied via PVD (physical vapor deposition). Provides extreme hardness (hard as carbide) and excellent lubricity when used with a lubricant. Not recommended for stainless steel, copper, or nickel. Approx. hardness: *Vickers 2300.

DayTAN™ (XAN)—ultra-hard, high-aluminum PVD coating. Absorbs shear stress and provides high temperature resistance. Ideal for HSLA, dual phase, and TRIP steels. Approx. hardness: *Vickers 3400.

TiCN (XCN)—very hard PVD, thin film. Provides ultra hardness (harder than carbide) and superior abrasive wear resistance. Approx. hardness: *Vickers 3000.

XNM—PVD, solid film. Produces lower coefficient of friction than other coatings. Provides excellent lubricity. Approx. hardness: *Vickers 2000.

XNP—the ultimate coating for extrusion and forming applications. Also works well in shaving operations. Tolerance is ± .0002. Approx. hardness: *Vickers 3100.

DayKool™ (XCR)—cryogenic steel conditioning process, used primarily with hard, thick materials. Improves strength, toughness, and dimensional stability.

CrN (CRN)—excellent adhesion, high toughness, and good corrosion resistance. Primary applications are metal forming (copper, brass, bronze), metal die casting, and plastic injection molding. Approx. hardness: *Vickers 1800-2100.

ZertonPlus™ (XNA)—excellent wear resistance, thermal shock stability and hot hardness. Approx. hardness *Vickers 3200.

XNAProgress (XNAP)—ultra-hard PVD coating that absorbs shear stress; provides excellent high-temperature resistance. Ideal for stamping where tools are exposed to extreme stress profiles. A good alternative to TD coating without the dimensional changes associated with that process. Approx hardness: *Vickers 3200.

Diamond Like Carbon Coating (XCD)—combines high hardness with an extremely low coefficient of friction. Good protection against abrasive & adhesive wear. Approx. hardness *Vickers 5000.

Code / Delivery	Material
XN —DayTride® + 4 days	M2 & PS
XNT —DayTiN® + 3 days	M2 & PS
XAN —DayTAN™ + 4 days	M2 & PS
XCN —TiCN + 3 days	M2 & PS
XNM +12 days	M2 & PS
XNP + 8 days	M2 & PS
XCR —DayKool™ + 1 day	M2 & PS
CRN + 7 days	M2 & PS
XNA —ZertonPlus™ + 7 days	M2 & PS
XNAP—XNAProgress +12 days	M2 & PS
XCD +8 days	M2 & PS

* Vickers used when RC exceeds 80.
® DayTride and DayTiN are registered trademarks of Dayton Progress.
™ DayTAN, DayKool, and ZertonPlus are trademarks of Dayton Progress.

Standard Alterations

Punch Blanks

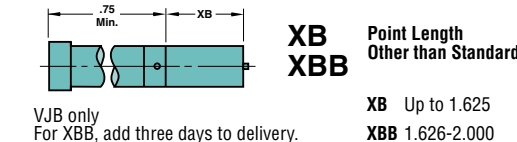

Shank Dia.	18	25	31	37	43	50	62	75	87	100
Min. XD VJB	.172	.218	.282	.344	.376	.438	.562	.688	.813	.938
Min. XD VPB	.126	.188	.251	.313	.376	.438	.562	.688	.813	.938

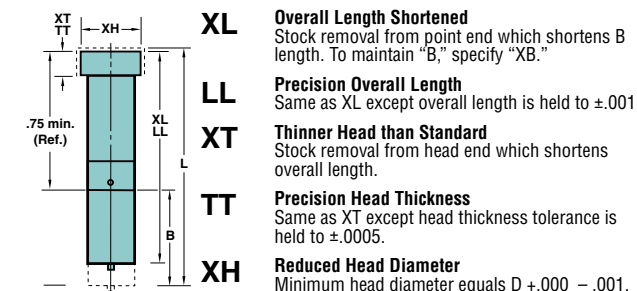

Shank Dia. D	18	25	31	37	43	50	62	75	87	100
Thickness T	.125	.125	.125	.188	.188	.188	.250	.250	.250	.250

XK No Side Hole For air ejection. No cost. VJB only
XJ Smaller Jektole Components See p. 34. VJB only

See page 35 for Shear Angles.

Straight Punches

Jektole® and Regular

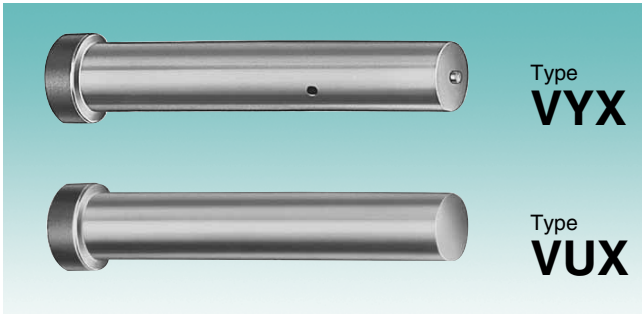

Material
 Steel: A2, M2 (RC 60-63)
 All heads are drawn to RC 40-55.
 P Tolerance $\begin{matrix} +.0002 \\ -.0000 \end{matrix}$

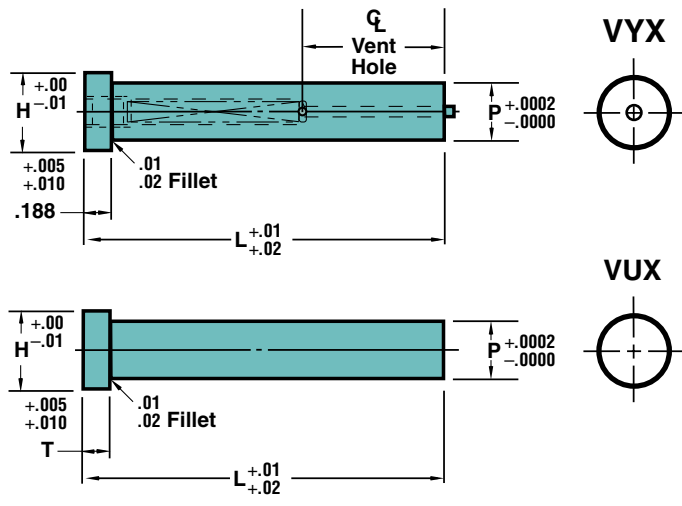

Standard Alterations

Straight and Cloospace Punches

Straight Punches

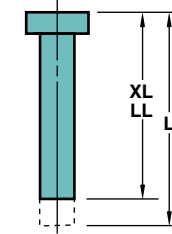

XL Overall Length Shortened
 Stock removal from point end.
LL Precision Overall Length
 Same as XL except overall length is held to $\pm .001$.

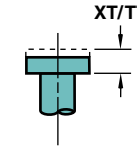

XT Thinner Head than Standard
 Stock removal from head end which shortens overall length.
TT Precision Head Thickness
 Same as XT except head thickness tolerance is held to $\pm .0005$.

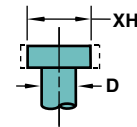

XH Reduced Head Diameter
 Minimum head diameter equals $D + .000 - .001$.

XK No Side Hole (VYX only)
 For air ejection. No cost.

XJ Smaller Jektole Components
 +3 days (VYX only) See p. 34.

See page 35 for Shear Angles.

Type	Range P	Head Dia. H	Head Thk. T	Vent Hole ϕ	L																				* Jektole Group
					1.25	1.50	1.75	2.00	2.25	2.50	2.75	3.00	3.25	3.50	3.75	4.00	4.25	4.50	4.75	5.00	5.25	5.50	5.75	6.00	
VYX	.1870-.2500	.375		.55	125	150	175	200	225	250	275	300													J2
	.2501-.3130	.438		.55 .80	125	150	175	200	225	250	275	300	325	350	375	400									J3
	.3131-.3750	.500	See DWG.	.60 .85	125	150	175	200	225	250	275	300	325	350	375	400									J4
	.3751-.4380	.562		.85 1.10		150	175	200	225	250	275	300	325	350	375	400									J6
	.4381-.5000	.625		.85 1.10		150	175	200	225	250	275	300	325	350	375	400									J6
	.5001-.6250	.750		.85 1.10		150	175	200	225	250	275	300	325	350	375	400									J9
VUX	.0620-.1250	.250		.125																					
	.1251-.1880	.312	.125																						
	.1881-.2500	.375	.188																						
	.2501-.3130	.438	.188	N/A	125	150	175	200	225	250	275	300	325	350	375	400									N/A
	.3131-.3750	.500	.188																						
	.3751-.4380	.562	.188																						
	.4381-.5000	.625	.188																						
	.5001-.6250	.750	.188																						

*See p. 32 for additional information.

HOW TO ORDER

Specify:	Qty.	Type	P	L	Steel
Example:	5	VYX	P.324	250	A2
	2	VUX	P.492	325	M2

Standard Alterations

Versatile straight and cloospace punches are available in sizes other than those shown in the chart above and on p.17.

When ordering, you are asked to specify different designations for various non-standard dimensions. For example, if the P dimension is outside the standard range, an "X" is placed in front of the P dimension, e.g., "XP." Also see "Standard Alterations" on the front of the pullout tab in this section for other special order designators.



CloSPACE Punches

Standard Alterations Straight and CloSPACE Punches

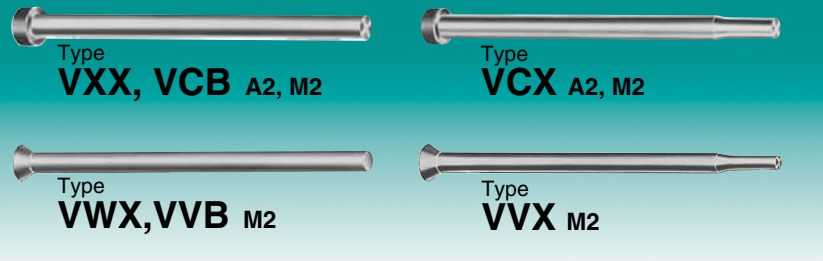

Regular Punches

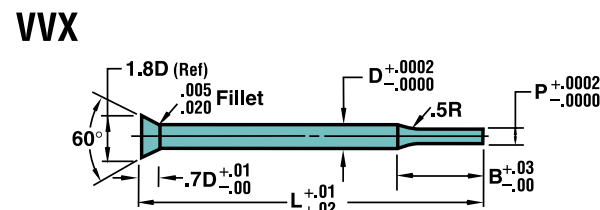
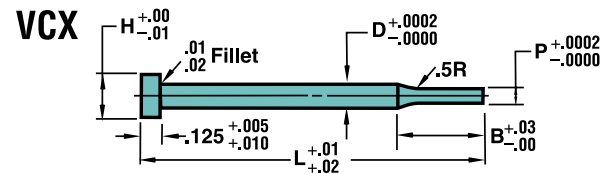

Punch Blanks

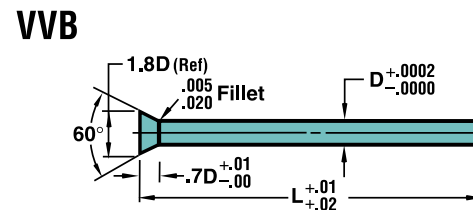
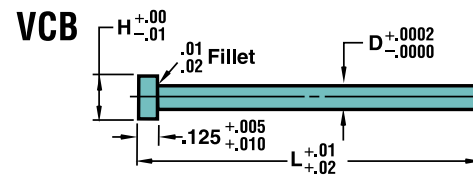

Straight Punches

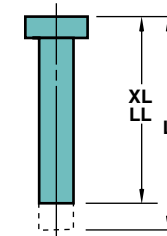

XL Overall Length Shortened
Stock removal from point end.

LL Precision Overall Length
Same as XL except overall length is held to ±.001.

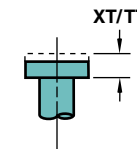

XT Thinner Head than Standard
Stock removal from head end which shortens overall length.

TT Precision Head Thickness
Same as XT except head thickness tolerance is held to ±.0005.

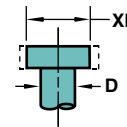

XH Reduced Head Diameter
Minimum head diameter equals $D + .000 - .001$.

XK No Side Hole (VYX only)
For air ejection. No cost.

XJ Smaller Jektote Components
+3 days (VYX only) See p. 34.

See page 35 for Shear Angles.

Material
Steel: A2, M2 (RC 60-63)
VXX, VCX, and VCB heads are drawn to RC 40-55.
P Tolerance $+0.0002$
 -0.0000
P to D $.0003$ ©

Straight Punches

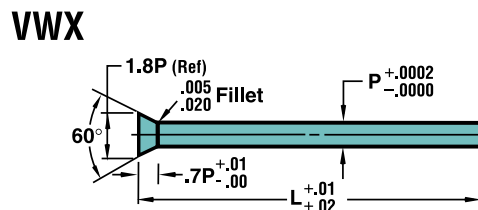
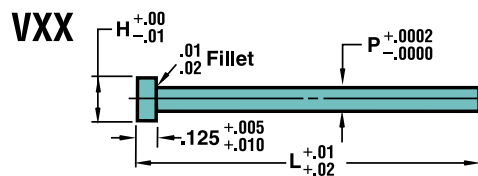

HOW TO ORDER

Specify: Qty. Type D Code L P Steel
Example: 5 VCX 12 200 P.098 M2

Type	Shank		Head Dia. H	Point Lgth. B	Range P	L										
	D	Code				1.50	1.75	2.00	2.25	2.50	2.75	3.00	3.25	3.50	3.75	4.00
Straight Punches VXX VWX			.125	N/A	.0300-.0500											
			.125		.0501-.0630											
			.160		.0631-.0940											
		N/A	.190		.0941-.1250	150	175	200	225	250	275	300	325	350	375	400
			.220		.1251-.1570											
			.250		.1571-.1880											
			.282		.1881-.2190											
Regular Punches VCX VVX	.0625	06	.125	.19	.0310-.0624											
	.0938	09	.160	.25	.0626-.0937											
	.1250	12	.190	.31	.0939-.1249											
	.1562	15	.220	.31	.1251-.1561	150	175	200	225	250	275	300	325	350	375	400
	.1875	18	.250	.31	.1563-.1874											
	.2188	21	.282	.31	.1876-.2187											
	.2500	25	.313	.31	.2189-.2499											
Punch Blanks VCB VVB	.0625	06	.125	N/A												
	.0938	09	.160													
	.1250	12	.190													
	.1562	15	.220			150	175	200	225	250	275	300	325	350	375	400
	.1875	18	.250													
	21	.282														
	25	.313														

CloSPACE Punches

Alteration Code	Product					
	VXX	VWX	VCX	VVX	VCB	VVB
XB			●	●		
XD			●			
XH	●		●		●	
XL	●	●	●	●	●	●
LL	●	●	●	●	●	●
XP			●	●		
XT	●		●		●	
TT	●		●		●	

For an explanation of the alteration codes shown above, see the "Standard Alterations, Regular Punches" on the p.7 pullout tab.

EDM Die Button Blanks

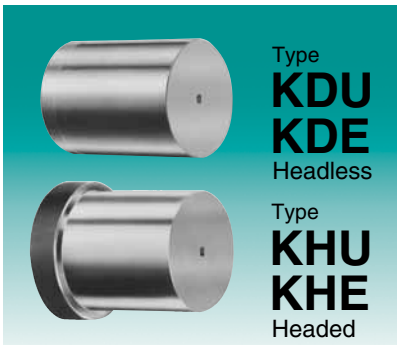

Material

Steel: M2 (RC 60-63)

Round P $+0.005$ P to D
D ≥ 1.75 $+0.0002$ $+0.0006$

HOW TO ORDER

Specify:	Qty.	Type	D Code	L	P	Steel
Example:	6	KDE	37	100	XP.020	M2
	5	KDU	50	112	.031	M2

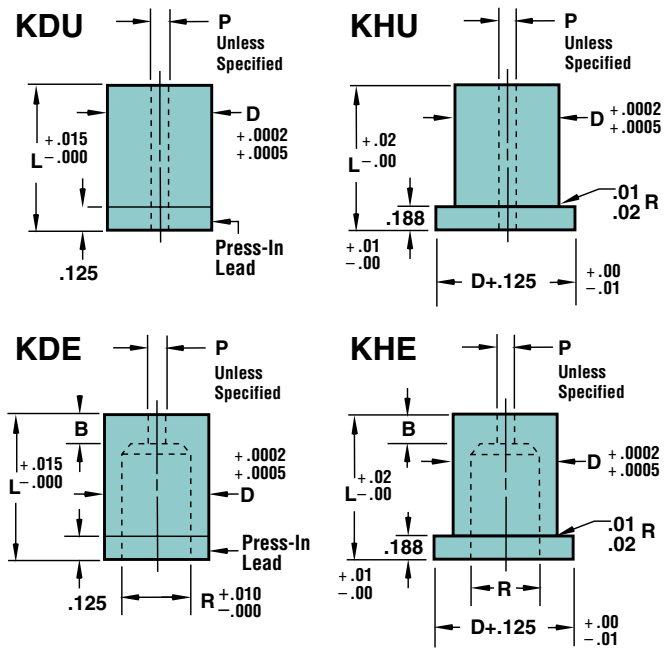

Type	Body		K_U			K_E				**L													
	D	Code	Std. P	Optional P		Std. P	Optional P	B	R	.75	.87	.93*	1.00	1.125	1.25	1.375	1.50	1.625	1.75	1.875	2.00		
KD_ KH_	.2500	25	.031	.020	—	.031	.020	—	.15	.156													
	.3125	31	.031	.020	—	.031	.020	—	.25	.191													
	.3750	37	.031	.020	—	.031	.020	—	.25	.228													
	.4375	43	.031	.020	—	.031	.020	—	.25	.281													
	.5000	50	.062	.020	—	.031	.020	—	.25	.312													
	.6250	62	.062	.020	.031	.093	.020	.031	.25	.391	75	87	93	100	112	125	137						
	.7500	75	.062	.020	.031	.093	.020	.031	.31	.468								150	162	175	187	200	
	.8750	87	.062	.020	.031	.093	.020	.031	.31	.578													
	1.0000	100	.062	.020	.031	.093	.020	.031	.31	.703													
1.2500	125	.062	.020	.031	.125	.020	.031	.37	.828														
1.5000	150	.062	.020	.031	.125	.020	.031	.37	1.094														
KD_	1.7500	175	.125	.020	.031	.125	.020	.031	.37	1.430													
	2.0000	200	.125	.020	.031	.125	.020	.031	.37	1.630													
	2.2500	225	.125	.020	.031	.125	.020	.031	.37	1.830	75	87	93	100	112	125	137	150	162	175	187	200	
	2.5000	250	.125	.020	.031	.125	.020	.031	.37	2.030													
	2.7500	275	.125	.020	.031	.125	.020	.031	.37	2.230													

**Maximum L for KDE & KHE is 150.

Standard "P" will be provided, unless otherwise specified.

*Headless Only



D ≤ 1.00 1 Day
1.00 < D ≤ 1.50 2 Days
(with XP, add 2 Days)

D > 1.50 4 Days
(with or without XP)

Features/Benefits

Select either round **KD_ Headless** or **KH_ Headed EDM Die Button Blanks**. Relief hole (R) provides sufficient clearance for slug removal during the stamping process in both versions of both types.

KDU and KHU Blanks are provided with a small straight through hole. They are commonly used for wire and vertical EDM operations. There are two key advantages with this type of blank: in wire cutting, a tapered relief can be cut instead of a round straight relief;

in conventional EDM applications, you can customize the size of the relief to the shape you are cutting.

KDE and KHE Blanks are used with conventional (vertical) EDM machines. The hole (P) is used to introduce dielectric to the spark gap to flush away eroded particles of steel. For the fastest delivery, use the hole (P) dimension given in the chart. If a larger hole is desired, simply specify "XP" and indicate the dimension.

Standard Alterations

Die Buttons

Dayton Slug Control

Dayton Slug Control is a guaranteed method for reducing the risk of pulling slugs to the die surface during withdrawal of the punch. A series of grooves is designed inside the die button (see drawing). There, the slugs are trapped until they fall freely through the relief. The use of Dayton Slug Control has no effect on hole size, and will not require any changes in current regrind practices.



Our guarantee: *Use Dayton Slug Control in a stamping die now pulling slugs. If, for any reason, you are not completely satisfied, we will refund the full cost of the Slug Control alteration. (We cannot guarantee the retention of slugs when clearance exceeds 10% per side.)*

Ordering

Dayton Slug Control is easy to specify and order. Simply add the information that is unique to your application to the die button catalog number. Please specify XSC for alteration and show material thickness (inches) and clearance per side (percentage).

HOW TO ORDER

Catalog Number				Your Specs			
Inch	VNX	62	100	P.250	XSC	MT.0125	CS 5
Type	D	L	P		Alt. Code	Mat'l Thickness (inches)	Clear Per Side (%)

For additional information, contact your Dayton distributor.

XP, XW

P and W Dimensions Larger than Standard

Body Code	Max P/G
18	.130
25	.190
31	.240
37	.290
43	.340
50	.390
62	.500
75	.600
87	.700
100	.800
125	1.000
150	1.200

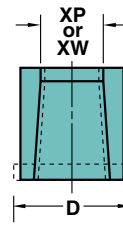

XB

Land Length Shorter (no charge) or Longer than Standard

Rounds		
Hole Range	Max B	
.0310-.0620	2P	
.0621-.0930	.187	
.0931-.1580	.250	
.1581-.2350	.312	
.2351-.3000	.375	
.3001-.4000	.437	
.4001-Over	.500	

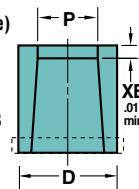

*No max XB on shaped dies

XD

Reduced Body Diameter

Head diameter does not change with body reduction.

Body Code	Min XD	Max P/G
18	.126	.076
25	.188	.130
31	.251	.190
37	.313	.240
43	.376	.290
50	.438	.340
62	.562	.437
75	.688	.550
87	.813	.650
100	.938	.750
125	1.188	.950
150	1.438	1.150

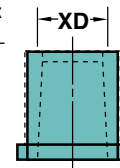

XBL

Straight Through Land

The land length (B) equals the overall length. Can be used for bushings, guides and a variety of other applications.

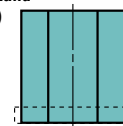

*Round die buttons only

XL

Overall Length Shortened

Min. overall length
VN: .25
VR: .25 + T

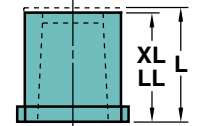

LL

Precision Overall Length

Same as XL except overall length is held to ± .001.

XT

Thinner Head than Standard

Stock removal from head end which shortens overall length.

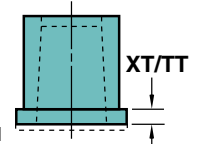

TT

Precision Head Thickness

Same as XT except head thickness tolerance is held to ± .0005.

XH

Reduced Head Diameter

Minimum head diameter equals D + .000 - .001.

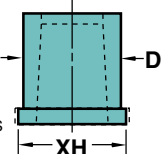

XSC

Slug Control eliminates slug pulling

(When ordering Dayton Slug Control, please specify XSC in place of the standard die button code, as well as your specifications. See the "How to Order" example on the front of this tab.)

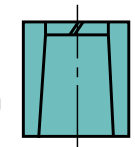

XAR

Increased Taper Relief

(10° per side max) Standard. B length unless XB is specified. Default angle is 1° when an angle is not specified.

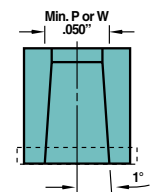

XN

+4 days

DayTride® A unique wear-resistant surface treatment for M2 & PS only.

Multi-Location™ Retainers

Multiple Head Type Punch Retainer

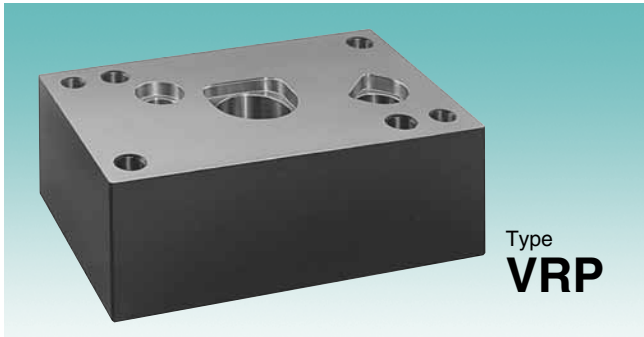

Type
VRP

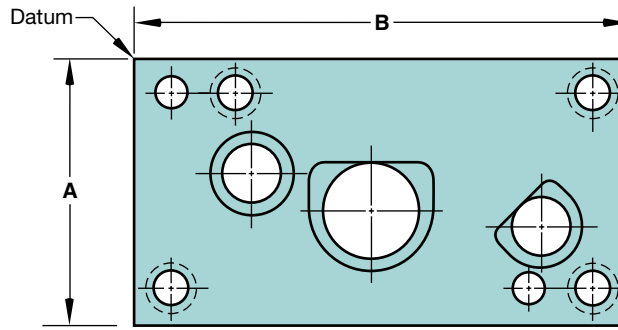

View from the punch head side.

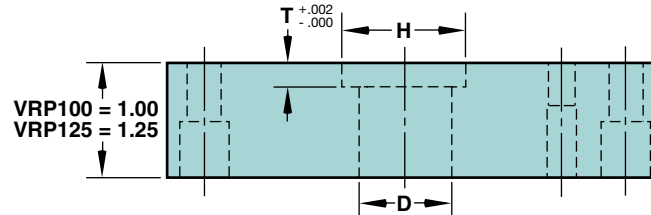

VRP100 = 1.00
VRP125 = 1.25

Specify screw and dowel size and location.



1-6 Holes, 5 Days
7+ Holes, 8 Days

Type	A	L													
		2.50	2.75	3.00	3.25	3.50	3.75	4.00	5.00	6.00	7.00	8.00	9.00	10.00	12.00
VRP	2.00	2025	2027	2030	2032	2035	2037	2040	2050	2060	2070	2080	2090	2010	2012
	2.75		2727	2730	2732	2735	2737	2740	2750	2760	2770	2780	2790	2710	2712
	3.00			3030	3032	3035	3037	3040	3050	3060	3070	3080	3090	3010	3012
	4.00							4040	4050	4060	4070	4080	4090	4010	4012
	6.00								6060	6070	6080	6090	6010	6012	6012
	8.00									8080	8090	8010	8012	8012	8012

HOW TO ORDER

Example:

Retainer Type	Catalog No.	Special Size	
VRP100	3070	A _____	B _____

Multi-Location™ Retainers						
Hole No.	Component		Location		Locking Device	
	Type	Size	X Axis	Y Axis	Location	Type
1	Dowel	5/16 S.F.*	.375	-.375	—	—
2	S.H.C.S	5/16	1.000	-.375	—	—
3	VJR	62	2.090	-1.375	90°	X2
4	Clear	1.281	4.250	-1.062	—	—
5	Jackscr.	STD.	0.687	-.937	—	—

*Slip Fit

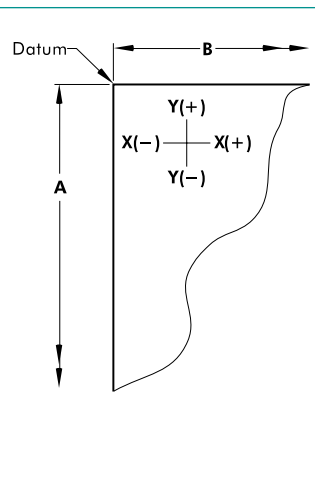

See the back of the pullout tab for additional information on VRP Locking Devices.

Multi-Location™ Retainers require special order forms, which are available on request. Specify all dimensions from the datum: Use the drawing above for reference.

Multi-Location™ is a trademark of Dayton Progress Corporation.

Standard Alterations

Multi-Location™ Retainers

Standard Jackscrew Hole

Jackscrews make it easier to pull retainers off the dowels.

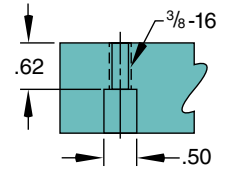

Special Size

Any amount of material can be removed from the sides of the retainer for a custom size. Edges are saw cut $\pm .03$.

Clearance Holes

Clearance holes or tapped holes can be detailed, as shown in the order example.

Holes are drilled through the retainer unless otherwise specified.

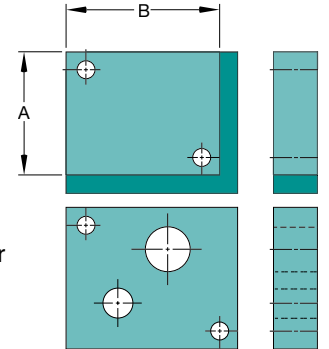

Location $\pm .010$

Diameter $+.015$
 $-.000$

The following alterations require detailed drawings:

Notches

Notches to clear other tooling can be added to any side of the retainer. Notches are saw cut $\pm .03$.

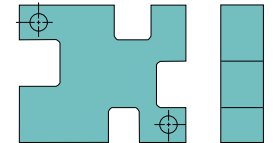

Angles

As with notches, angles can be added to clear other tooling in the die. Angles are saw cut $\pm .03$.

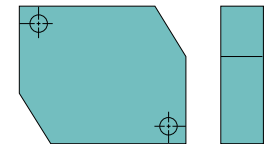

Space Requirements

D	T	H
.1250	.125	.281
.1875	.125	.344
.2500	.188	.406
.3125	.188	.469
.3750	.188	.531
.5000	.188	.656
.6250	.188	.781
.7500	.188	.906
1.0000	.188	1.156

Hole Reference

Re: Datum Point

Dowel Holes	$\pm .0003$
Screw Holes	$\pm .005$
Component Holes	$\pm .0003$

True Location™ Retainers

Single Head



Locking Mechanism

The locking mechanism for the Multi-Location™ VRP Retainer and the True Location™ VRTS Retainer (for shaped punches) is part of the retainer itself, and is used to lock the shaped punches, thus providing accurate radial location.

The flat for the VRTS Retainer is always located as shown in the drawing on the left. The flats for the VRP Retainer can be located at *any* angle by specifying the angle from 0°.

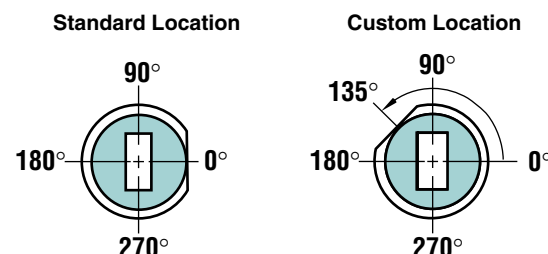

Specify radial location on VRP Retainers for shaped punches.

Flat Tolerances

FLAT	
F	RADIAL
+0.001	.001/inch
-0.000	

Shim/Backing Plate

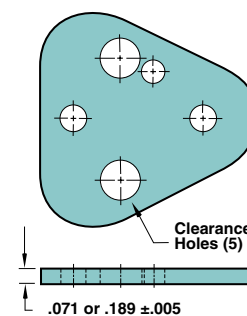

Shim Plates can be used as an effective way to accurately time pilot entry, or used as a backing plate.

Shim Plates can also be used on any Dayton Progress triangular-shaped retainers.

D	Thickness T	
	.189 (Rc54-56)	.071 (Soft)
25	URBP 0648	URSP 0618
37	URBP 1048	URSP 1018
50	URBP 1348	URSP 1318
62	URBP 1648	URSP 1618
75	URBP 2048	URSP 2018
85	URBP 2248	URSP 2218
100	URBP 2548	URSP 2518
125	URBP 3248	URSP 3218

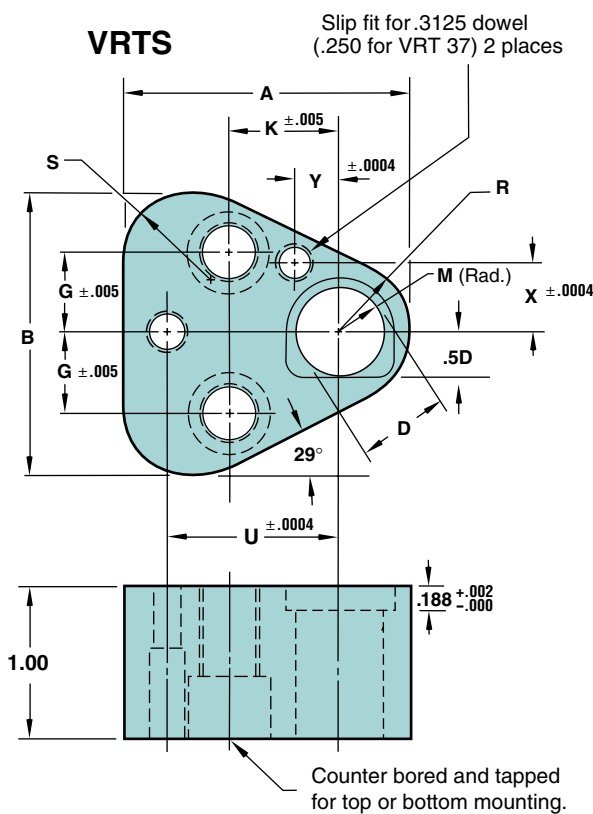
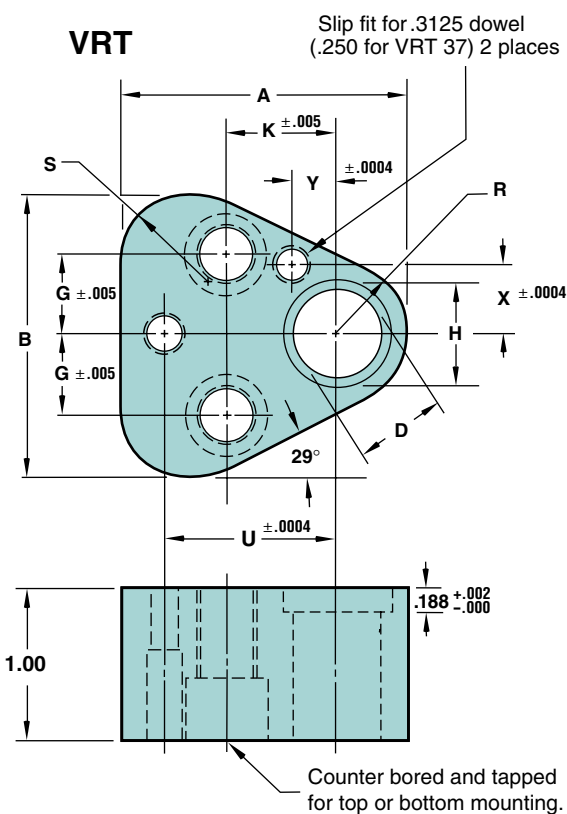

Type	Code	D	A	B	G	K	R	S	U	X	Y	Screw Size	Tapped Hole
VRT/VRTS	37	.3750	1.75	1.72	.438	.750	.38	.47	1.060	.354	.295	5/16-18	3/8-16
	50	.5000	2.00	1.97	.562	.750	.50	.60	1.180	.472	.256	5/16-18	3/8-16
	62	.6250	2.12	2.09	.625	.750	.56	.66	1.250	.532	.236	5/16-18	3/8-16
	75	.7500	2.38	2.34	.688	.750	.69	.79	1.320	.650	.197	5/16-18	3/8-16
	100	1.0000	2.75	2.72	.781	.938	.88	.97	1.600	.866	.276	1/2-13	5/8-11
	125	1.2500	2.75	2.72	.781	.938	.88	.97	1.600	.866	.276	1/2-13	5/8-11

Retainer sets include: • 2 Dowels
• 2 Screws

HOW TO ORDER

Specify:	Qty.	Type	D Code
Example:	3	VRT	37
	4	VRTS	62

True Location™ is a trademark of Dayton Progress Corporation.

Classified Shapes

Classified shapes (83 common shapes, no detailing required) are available on all punches, die buttons, and guide bushings, as indicated in this catalog. The 83 available common shapes are shown here and on p. 23. Also, see the outside of the pullout tab for notes and drawing references.

Ordering Information

*Corner Dimensions

Dimensions should be the theoretical sharp corners for shapes C22, C24, C34, C61, and C88. However, some reduction of these dimensions will result from fitting the punch and die button under conditions where the clearance is .0025 or less per side.

†Shape Center

Shapes are centered on the punch shanks as shown. Shapes in guide bushings and die buttons are also centered as shown with the exception of shapes C22 and C34. Due to clearance, the P dimension on these shapes will not be centered.

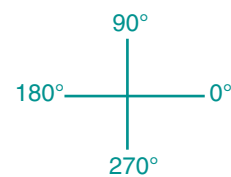

Keys

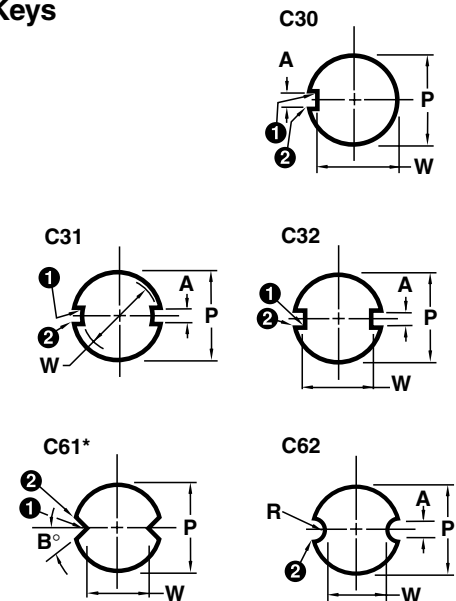

Triangles/Trapezoids

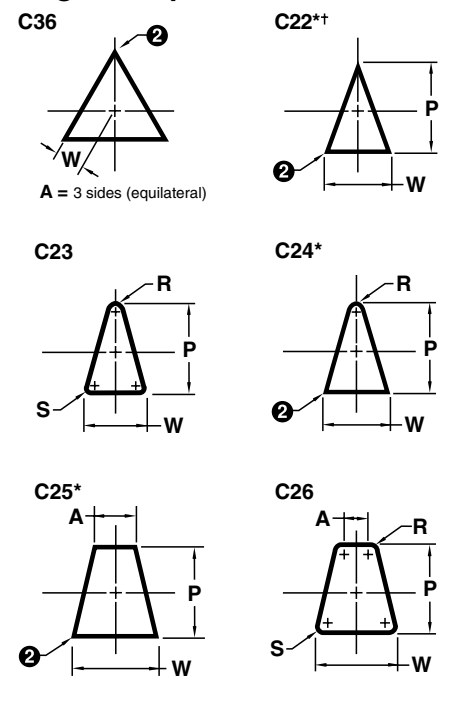

Flatted Rounds

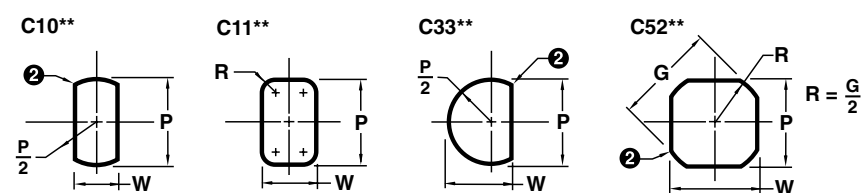

Mono Lobes

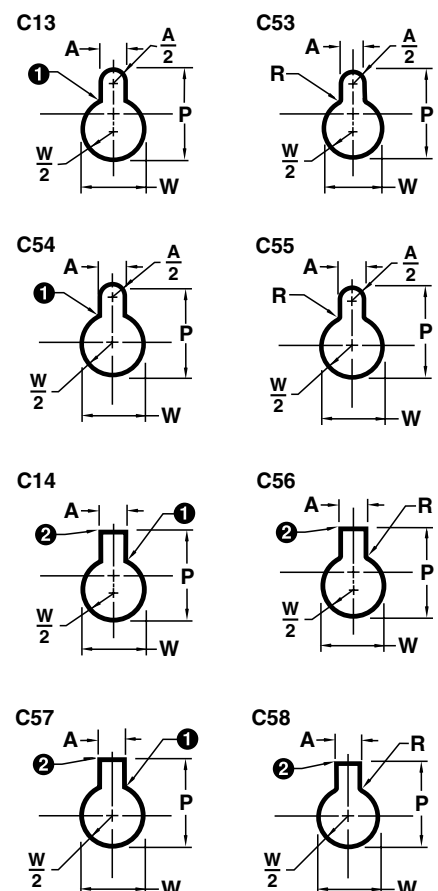

Multi Lobes

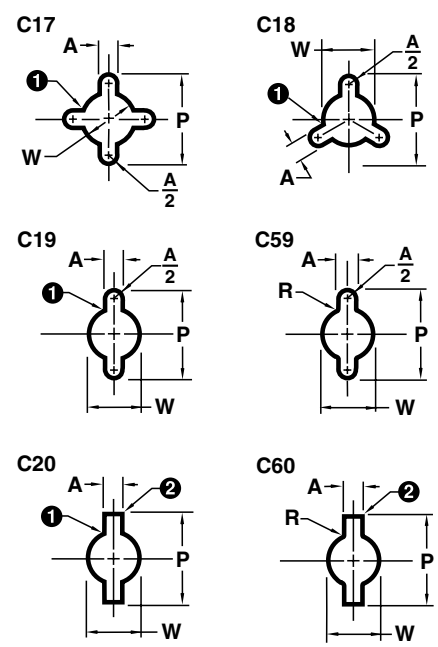

Classified Shapes

Miscellaneous

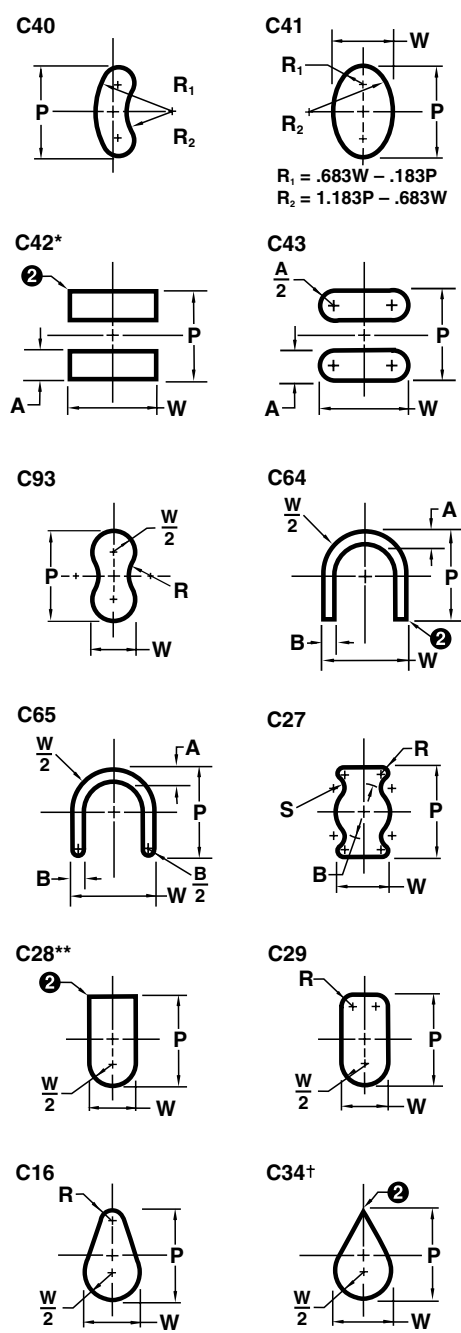

Ts

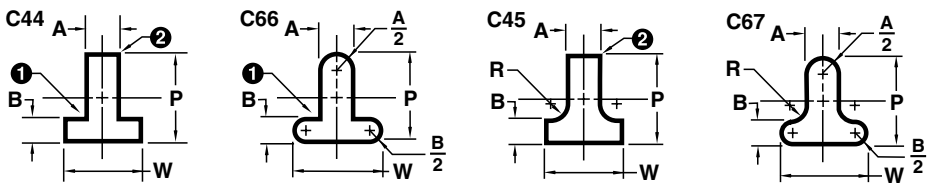

Us

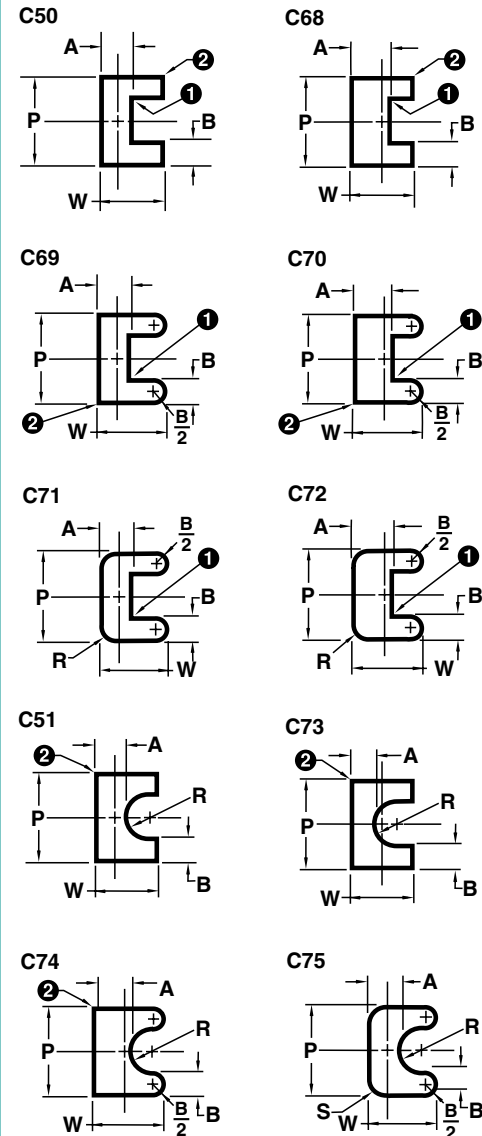

Ls

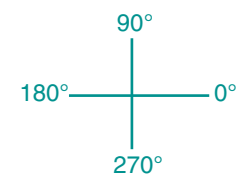
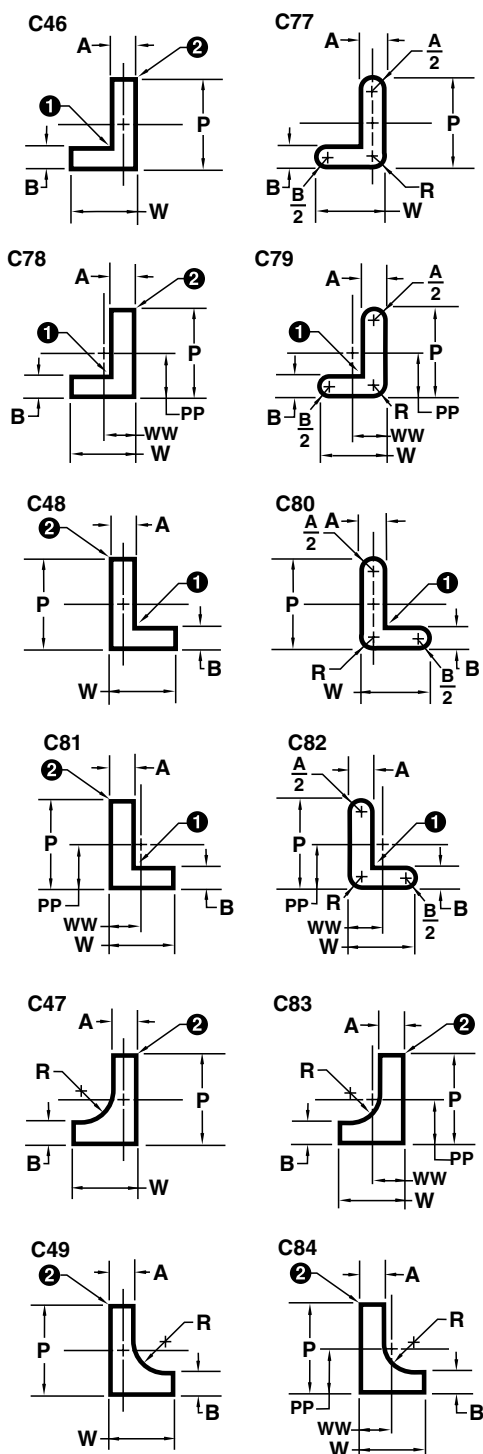

Polygons

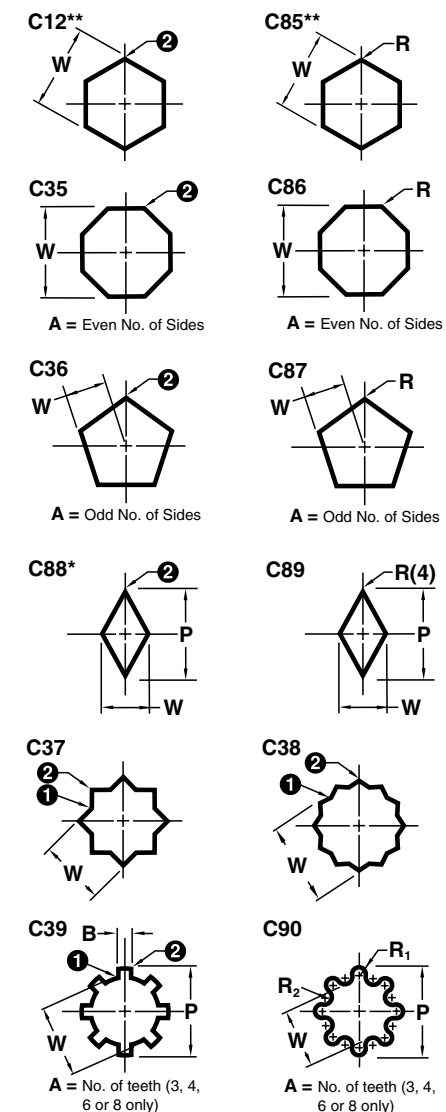

Duo Tees

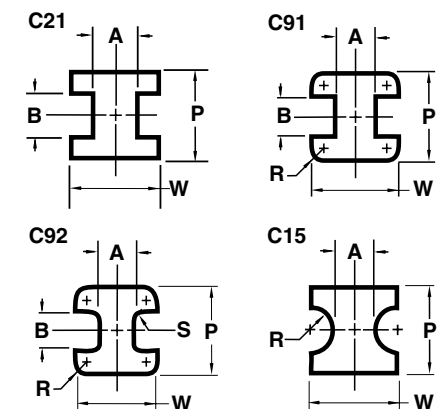

Classified Shapes Ordering Information

Reflected View—Punches and Guides

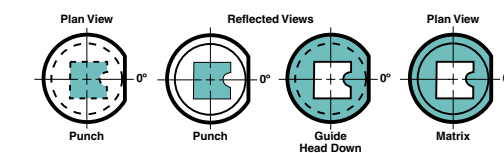

The reflected view is used for punches and guides. It is the view as seen in a mirror held below a punch or guide in its operating position. It is the same as a plan view from the head end, in which the point shape is shown dotted. A reflected view is shown with solid lines.

Orientation and Locking

The locking device orientation is standard at 0°. For types of locking methods and custom locations, see p. 30.

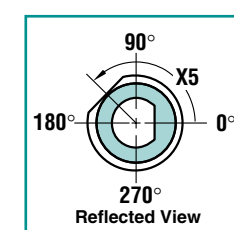

Clearance

Normal grinding methods produce ① .007 max fillet on the punch and ② .007 max fillet on the die button with matching corner shape on the die button and punch, respectively. When ordering die buttons, please specify punch dimensions and clearance per side (Δ). (If the clearance is .0025 Δ, Dayton will break sharp corners when the punches and die buttons are ordered together.)

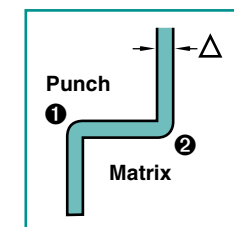

Guide Bushings

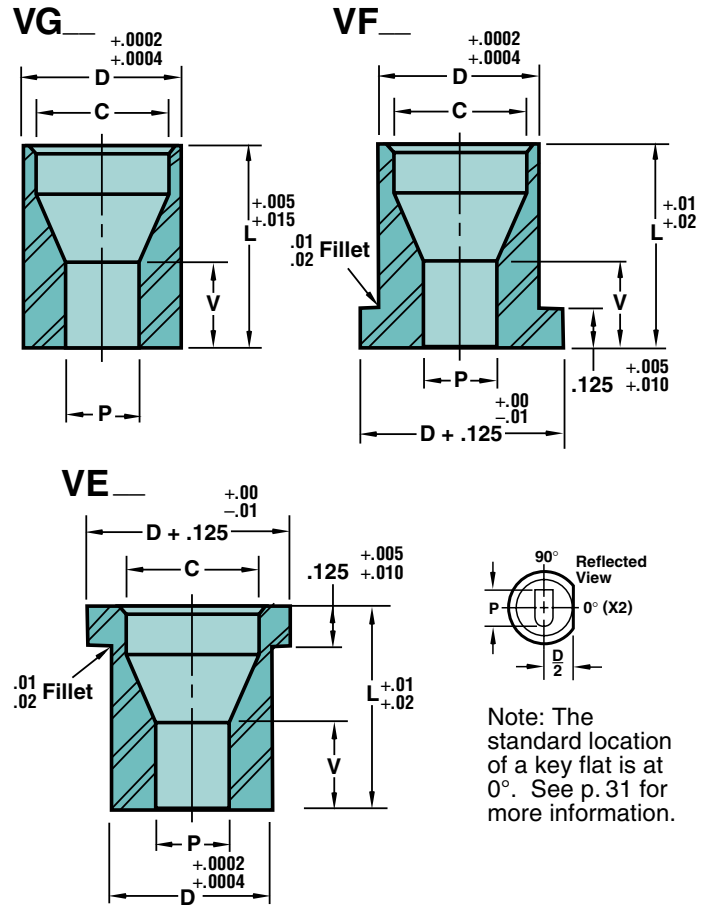
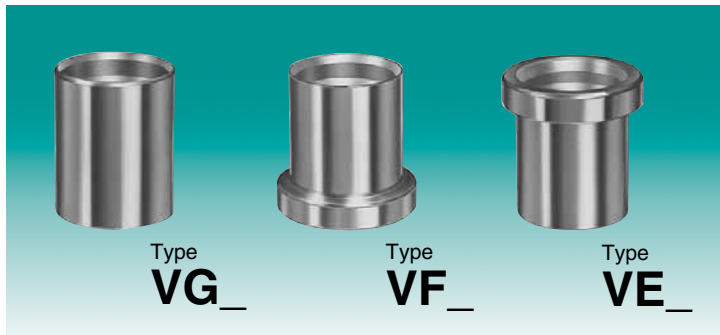

Material
 Steel: A2 (RC 60-63)
 P&W Tolerance $\pm .0002$ to $-.0000$
 P to D $.0003$



1 Check your P&W dimensions to be certain the diagonal G does not exceed the maximum shown.

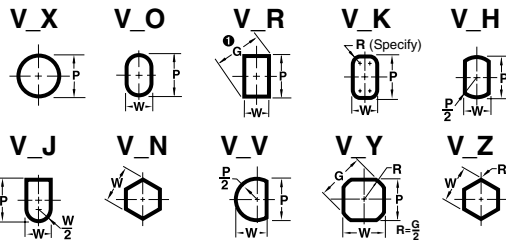

Note: The standard location of a key flat is at 0°. See p. 31 for more information.

	Body		Round	Shape		C'Bore Dia. C	L			
	D	Code		Range P	Min. W		Max. P/G	.3125	.3750	.5000
Headless VG	.1875	18	.062-.130	.050 - .130	.141	31				
	.2500	25	.062-.170	.050 - .170	.201					
	.3125	31	.093-.212	.050 - .212	.261		37	50		
	.3750	37	.125-.255	.050 - .255	.323					62
	.4375	43	.187-.297	.075 - .297	.386					
	.5000	50	.212-.344	.075 - .344	.448					
Head Down VF	.1875	18	.062-.130	.050 - .130	.141	31				
	.2500	25	.062-.170	.050 - .170	.201					
	.3125	31	.093-.212	.050 - .212	.261		37	50		
	.3750	37	.125-.255	.050 - .255	.323					62
	.4375	43	.187-.297	.075 - .297	.386					
	.5000	50	.212-.344	.075 - .344	.448					
Head Up VE	.1875	18	.062-.130	.050 - .130	.141	31				
	.2500	25	.062-.170	.050 - .170	.201					
	.3125	31	.093-.212	.050 - .212	.261		37	50		
	.3750	37	.125-.255	.050 - .255	.323					62
	.4375	43	.187-.297	.075 - .297	.386					
	.5000	50	.212-.344	.075 - .344	.448					

Applications

Guide bushings should be ordered a minimum of .0005 larger than the punch point diameter with which they are to be used.

Alterations—Guide Bushings

Product	Rounds	Shapes
XH	●	●
XT	●	●
TT	●	●

For an explanation of the alteration codes shown above, see the "Standard Alterations, Regular Punches" on the p.7 pullout tab.

Guide Chart

Hole Range P or G	Land Length V
Up to .0650	2P
.0651-.0950	P + .065
.0951-.4250	.82P + .082

HOW TO ORDER

Specify:	Qty.	Type	Code	L	P (or P&W)
Example:	4	VEX	37	62	P.146
	2	VFO	50	50	P.250, W.075

Micro Guides/Die Buttons

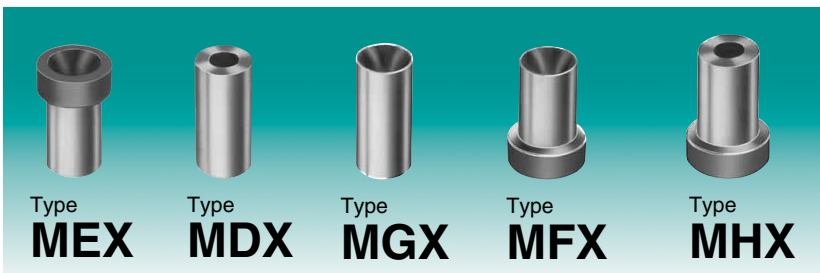

Material
 Steel: A2 (RC 60-63)
 P&W Tolerance $\begin{matrix} +.0002 \\ -.0000 \end{matrix}$
 P to D $\begin{matrix} .0003 \\ \odot \end{matrix}$



Guide Chart

Hole Range P	Land Length V
Up to .0650	2P
.0651-.0950	P + .065
.0951-.4250	.82P + .082

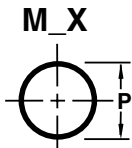
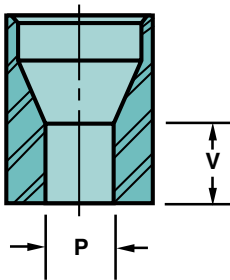

Guides

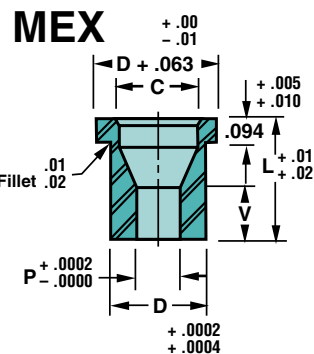

MGX

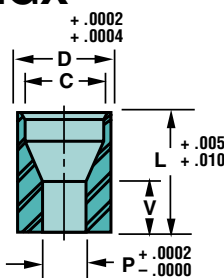

MFX

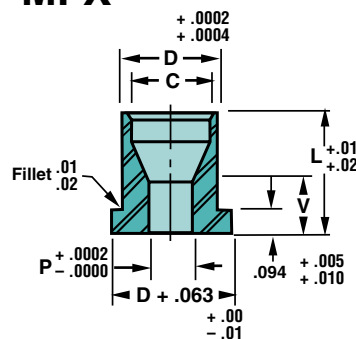

Die Buttons

	Body		Range P	C'Bore Dia. C	L			
	D	Code			.250	.3125	.375	.500
MGX Headless Guide	.1250	12	.031 - .062	.076	25	31	37	
	.1875	18	.046 - .130	.141		31	37	
MFX Head-Down Guide	.1250	12	.031 - .062	.076		31	37	
	.1875	18	.046 - .130	.141		31	37	
MEX Head-Up Guide	.1250	12	.031 - .062	.076		31	37	
	.1875	18	.046 - .130	.141		31	37	
MDX Headless Die Button	.1250	12	.031 - .062	N/A		31	37	50
	.1875	18	.046 - .130	N/A		31	37	50
MHX Headed Die Button	.1250	12	.031 - .062	N/A		31	37	50
	.1875	18	.046 - .130	N/A		31	37	50

HOW TO ORDER

Specify:	Qty.	Type	Code	L	P (or P&W)
Example:	3	MEX	18	31	P.062
	3	MGX	12	31	P.044
	2	MFX	12	31	P.057
	3	MHX	18	37	P.060
	2	MDX	12	31	P.045

P is > .062

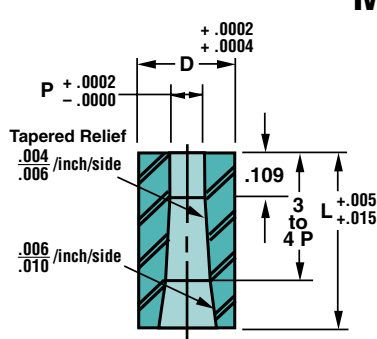

MDX

P is ≤ .062

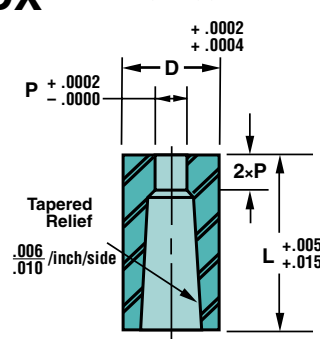

MHX

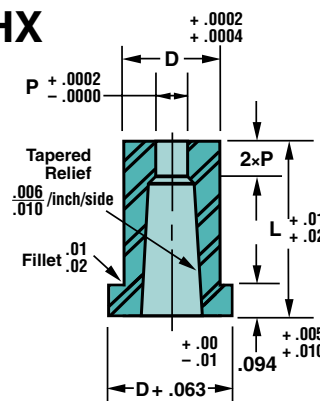
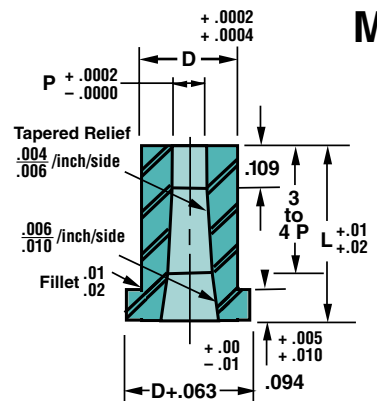

Quill Bushings/Guides

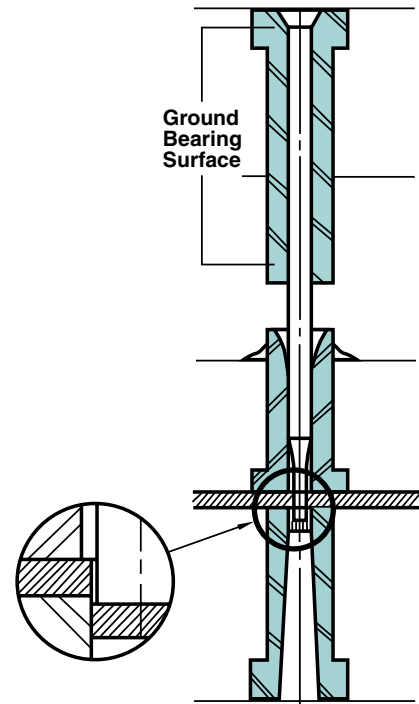
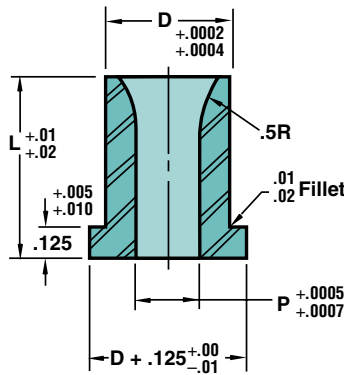
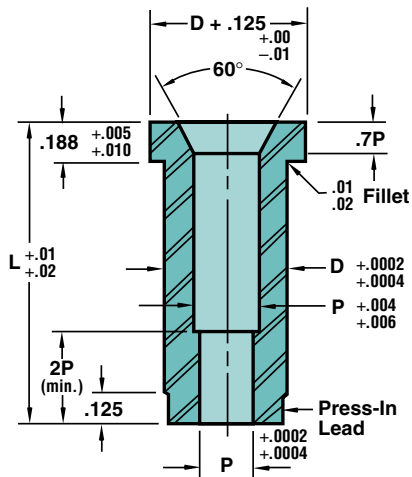
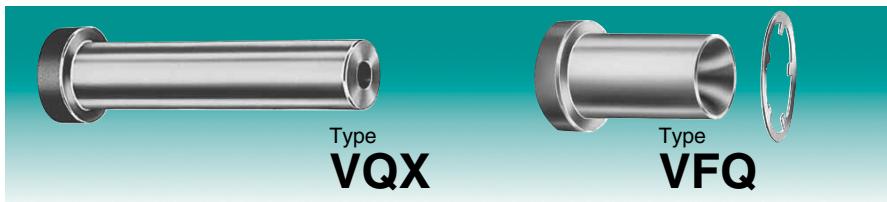

Material

Steel: A2 (RC 60-63)
Bearing: Bronze (VFQ)

Note: No alterations available on VFQ. VFQ, as shown above, comes complete with a halo washer that provides a head at both ends.

Matched Quill Sets

Matched Quill Sets are ideal for small hole applications where the risk of punch breakage is extremely high and where replacement costs must be considered.

Limitations

Body Code	XP		XD	
	Min. P	Max. P	Min. XD	Max. P
18	.0625	.094	.126	.0625
25	.0625	.125	.188	.0938
31	.0625	.156	.251	.1250
37	.0625	.188	.313	.1562
43	.0625	.219	.376	.1875

Quill Bushing Alterations

- XD** Reduced Shank Diameter
- XH** Reduced Head Diameter
- XL** Overall Length Shortened
- XP** P Dimensions Larger than Standard

Perfect Alignment

Ground bearings at both ends of the Quill Bushing assure precise punch-to-punch alignment. This eliminates the bending influence of unrelieved bushing holes, which are difficult to manufacture straight. Dayton manufactures products with a .002 to .003 relief per side between bearing surfaces, which eliminates this problem.

No Stock Distortion Risk

During stripping, the punch tends to pull the stock into the stripper void, which may cause part distortion. Dayton eliminates the distortion potential by manufacturing the product with a controlled limit, i.e., .015 per side maximum. Distortion cannot occur when the space between the guides and the punch (.5 D-P) is less than the stock thickness.

Body Code	Body D	Code	Punch Hole P	L				
				.500	.625	.750	1.000	1.250
VQX Press Fit Quill Bushings	.1875	18	.0625					
	.2500	25	.0938					
	.3125	31	.1250			75	100	125
	.3750	37	.1562					
	.4375	43	.1875					
VFQ Quill Guide Bushings	.1875	18	.0625	50				
	.2500	25	.0938		62			
	.3125	31	.1250					
	.3750	37	.1562			75		
	.4375	43	.1875					

HOW TO ORDER

Specify:	Qty.	Type	Code	L	Steel
Example:	3	VQX	31	75	A2
	4	VFQ	31	75	Bearing Bronze



VersaPlus® Premium Products

Precision, High-Performance Punches and Pilots

VersaPlus® Punches and Pilots are a premium line of precision, high-performance products that offer more features and benefits to users in industries where higher-than-normal production runs occur—and where optimum performance is a MUST.

VersaPlus® is “setting the new standard in high performance,” according to tool companies and manufacturers who have field-tested the products. For example, a furniture hardware manufacturer realized a production run improvement from 250,000 to 375,000—a 150% increase. In another test, a tool and die company increased run-time-to-sharpening from 100,000 pieces to 200,000.

VersaPlus® gives users the real “plus” through improved production capabilities, increased uptime, and lower costs.

For additional information or a copy of our latest VersaPlus® catalog, contact your Dayton Progress Distributor.



Extended Range Punches

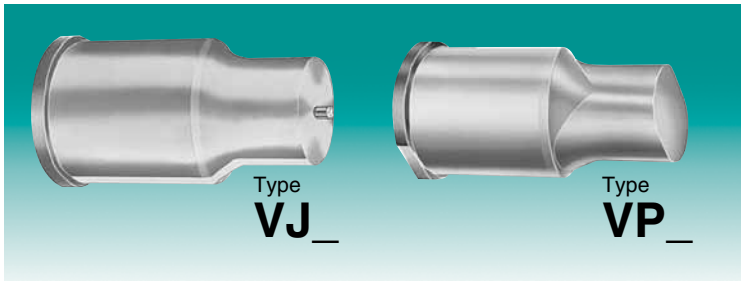

Shown here with optional key flat. See p. 31.

Material
 Steel: A2, M2, PS4 (RC 60-63)
 P&W Tolerance $\pm .0002$
 P to D $.0003 \text{ } \text{\textcircled{C}}$

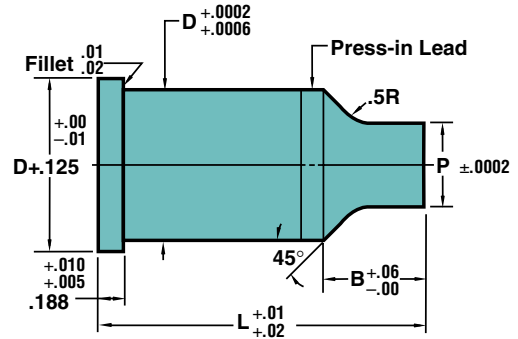

When D-P exceeds .406 a step will exist.

HOW TO ORDER

Specify:	Qty.	Type	Shank	L	P (or P&W)	Steel
Example:	3	VPR	200	1021	P1.206, W.582	M2

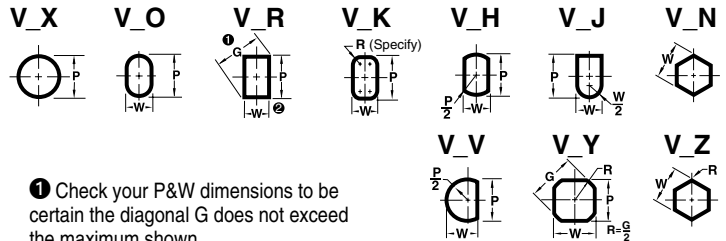

Shank D	Point Lgth. B	Round Range P	Shape Min. W Max. P/G	L																	Jektrole® Group				
				2.25	2.50	2.75	3.00	3.25	3.50	3.75	4.00	4.25	4.50	4.75	5.00	5.25	5.50	5.75	6.00	6.25		6.50	6.75	7.00	
1.250	1.25	.625-1.2499	.282-1.2500																					J12	
1.500		.750-1.4999	.300-1.5000																						J12
1.750		1.000-1.7499	.350-1.7500	1021	1122	1223	1330	2031	2132	2233	2340	3041	3142	3243	3350	4051	4152	4253	4360	5061	5162	5263	5370	J12	
2.000		1.187-1.9999	.400-2.0000																						J12
2.250		1.375-2.2499	.450-2.2500																						J12
2.500		1.625-2.4999	.500-2.5000																						J12
1.250	1.50	.625-1.2499	.282-1.2500																					J12	
1.500		.750-1.4999	.300-1.5000																					J12	
1.750		1.000-1.7499	.350-1.7500		1022	1123	1230	1331	2032	2133	2240	2341	3042	3143	3250	3351	4052	4153	4260	4361	5062	5163	5270	J12	
2.000		1.187-1.9999	.400-2.0000																					J12	
2.250		1.375-2.2499	.450-2.2500																					J12	
2.500		1.625-2.4999	.500-2.5000																					J12	

*See p.30 for more details.

Surface Coatings

Code / Delivery	Material
XN —DayTride® + 4 days	M2 & PS4
XNT —DayTiN® + 3 days	M2 & PS4
XAN —DayTAN™ + 4 days	M2 & PS4
XCN —TiCN + 3 days	M2 & PS4
XNM +12 days	M2 & PS4
XNP + 8 days	M2 & PS4
XCR —DayKool™ + 1 day	M2 & PS4
CRN + 7 days	M2 & PS4
XNA —ZertonPlus™ + 7 days	M2 & PS4
XNAP—XNAPProgress +12 days	M2 & PS4
XCD +8 days	M2 & PS4

For more information on Dayton Progress surface coatings, see the back of the pullout tab on p. 5.

© DayTride and DayTiN are registered trademarks of Dayton Progress.
 ™DayTAN and DayKool are trademarks of Dayton Progress.

Shear Angles

Shear Angles can be applied to all punch points. These angles are used primarily to reduce slug pulling. Single and Double Shears can be used to reduce the punching force as well as minimize slug pulling. These alterations are prepriced and do not add to the standard delivery of the product.

Shear Angles are also available on Classified Shapes, but are available as special order only.

Standard head flat and dowel locations are at 0°.

Simply add the alteration code shown next to the drawings, and the angle desired, to your punch catalog number. Tolerance on all angles is ± 15 minutes.

LL not available on XS19, XS21, XS22, and XS23.

HOW TO ORDER

Type	Code	L	P (or P&W)	Steel	Alteration
VPO	50	2332	P.400, W.300	A2	XS23 A3°

For Round Punches Only

XS19 Nail Point

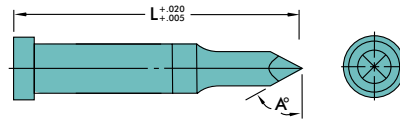

XS20 Chamfer

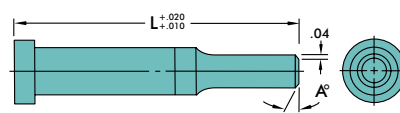

For Round & Shape Punches

Shown as reflected view.

XS21 Conical

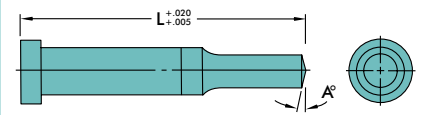

XS22 Double Shear

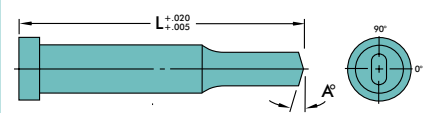

XS23 Single Shear

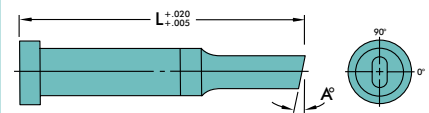

XS24 Single Shear Angle with Flat

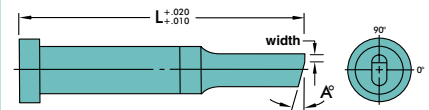

Locking Devices—Ordering Information

Orientation

The standard location for all locking devices is at 0°, and is always on the long side (P) of the shape. Custom locations are measured counterclockwise from 0°. (See drawing below.)

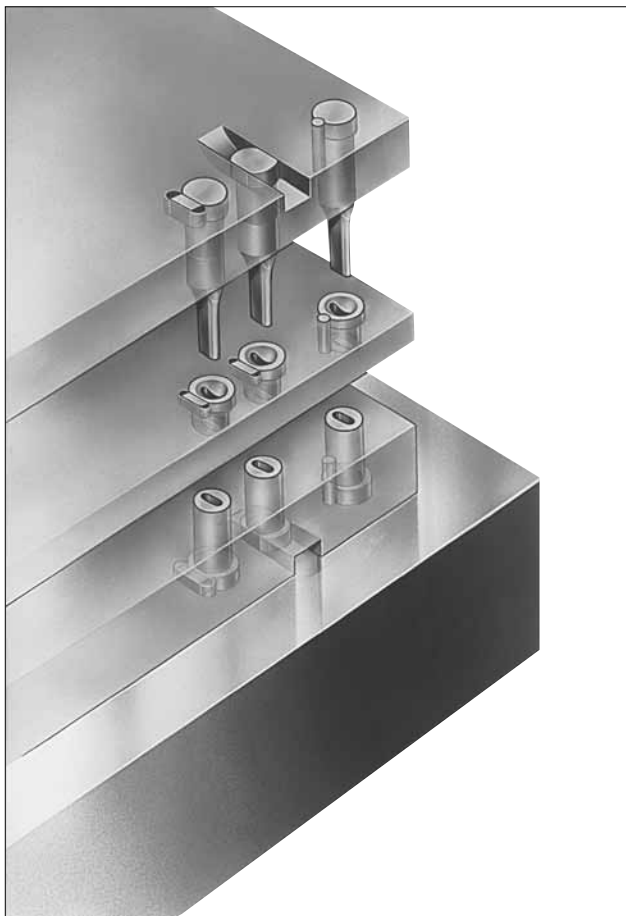
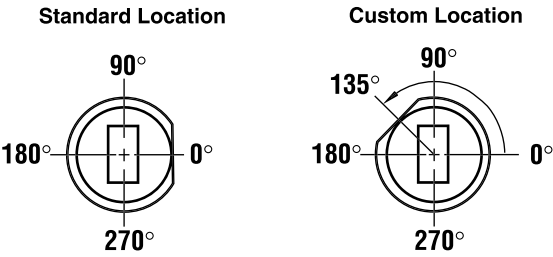

Views

A Plan View is used for the die button, and a Reflected View is used for the punch or guide. The Reflected View, a mirror image, simplifies orientation—locking devices are all in the same position.

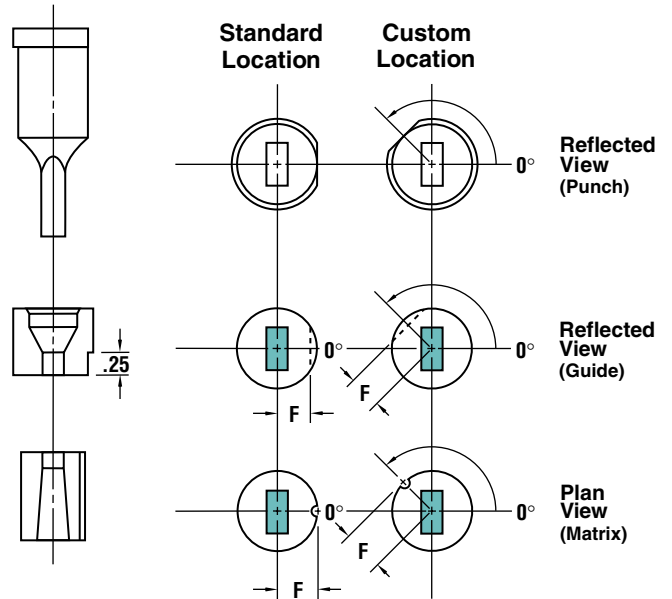
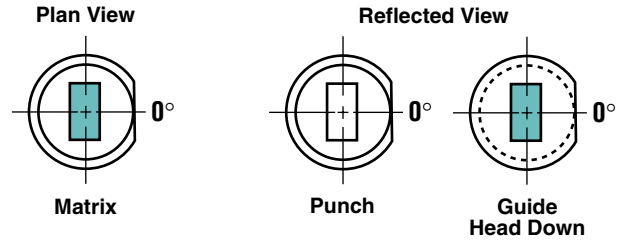

How To Specify

The most common locking devices—flat, double flat, and dowel—are available. Simply select the type, then add the code to the component description shown on p. 31.

HOW TO ORDER

Specify:	Qty.	Type	Code	L	P (or P&W)	Steel
Example:	1	VJJ	37	312	P.321, W.189	A2, X2
	3	VRO	50	137	P.3125, W.1562	A2, X2

Location Tolerance

Flat		Dowel	
F	Radial	F	Radial
+ .0002	.0005/ inch	+ .0002	0°2'
- .0000		- .0000	

Locking Devices—Flats vs. Dowel Slots

Flats

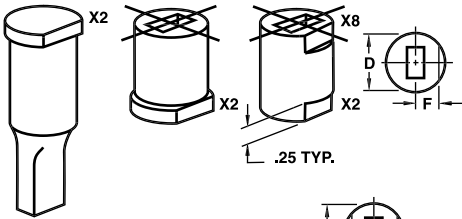

F Dimension
(.5D on Headed Products)
Headless Die Buttons and Guides

Body Dia.	18	25	31	37	43	50
F	.080	.110	.135	.165	.190	.220
Body Dia.	62	75	87	100	125	150
F	.270	.325	.380	.435	.540	.650
Body Dia.	175	200	225	250	275	
F	.775	.900	1.025	1.150	1.275	

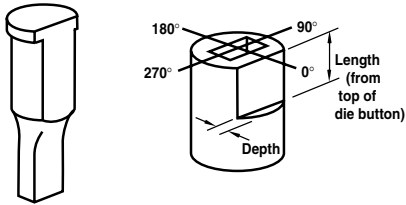

The depth of the flat is taken from the shank, not the head, on punches.

Key Flats vs. Dowel Slots

Maximum hole dimensions in die buttons were designed with key flats in mind. There are instances where, if using a dowel slot in a headless die button, the dowel hole could break into the relief. For this reason, there are two ways to specify the location of the dowel. **X0** (standard/alternate location) and **X1** (custom location) are located .5D from centerline. However, when hole dimensions are approaching the high limit of "P," **X4** (standard/alternate location) or **X7** (custom location) may be specified. This relocates the dowel outward to assure no interference between the dowel and the relief hole. Note: When the die button diameter is over .5000, the centerline dimension is .5D on all dowels.

To determine if you have an interference problem, see pp. 18-19 for information on Die Button construction.

Dowel Slots

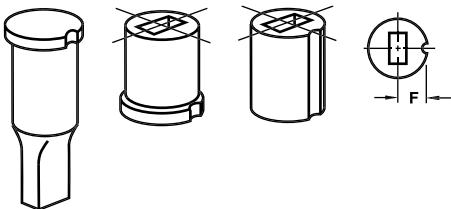

Standard & Alternate Locations

Standard Location is at 0°.
Alternate Location is 90°, 180°, or 270°.
Alternate Locations are available at no additional charge.

Single Flats: X2 & X8

Locking Devices	Punches	Die Buttons
X2	Top	Bottom
X8	N/A	Top

Order Example:
X2 — 90°

Double Flats: X3

Locking Devices	Punches	Die Buttons
X3	Top	Bottom

Order Example:
X3 — 90°

Second Flat is *always parallel* to the first flat.

Additional Flats (From Top)

Code	Depth	Length
X81*	.060	.500
X82*	.060	.625
X83*	.060	.750
X84	.060	Full Length
X85*	.093	.500
X86*	.093	.625
X87*	.093	.750
X88	.093	Full Length
X89*	Specify Dimensions	

* not available on headed die buttons (X89 available only if flat is full length).

Dowel Slots: X0**, X4, X41 & X43

Locking Devices	Dowel Diameter
X0**	.1250
X4	.1250
X41	.1875
X43	.2500

Order Example: X0 — 180°

**available on headless die buttons only

Custom Locations

Custom Location is *any angle other than:* 0°, 90°, 180°, or 270°.

Single Flats: X5 & X9

Locking Devices	Punches	Die Buttons
X5	Top	Bottom
X9	N/A	Top

Order Example:
X5 — 135°

Double Flats: X6

Locking Devices	Punches	Die Buttons
X6	Top	Bottom

Order Example:
X6 — 135°

Additional Flats (From Top)

Code	Depth	Length
X91*	.060	.500
X92*	.060	.625
X93*	.060	.750
X94	.060	Full Length
X95*	.093	.500
X96*	.093	.625
X97*	.093	.750
X98	.093	Full Length
X99*	Specify Dimensions	

* not available on headed die buttons (X99 available only if flat is full length).

Dowel Slots: X1**, X7, X71 & X73

Locking Devices	Dowel Diameter
X1**	.1250
X7	.1250
X71	.1875
X73	.2500

Order Example: X71 — 135°

F Dimension for Headed Punches and Die Buttons

$$F = .5D + .5 \text{ Dowel Dia.}$$

F Dimension for Headless Die Buttons Only

Body Diameter		25	31	37	43	50	62	75	87	100	125-400
X0, X1	F	.1250	.1562	.1875	.2188	.2500	.5D	.5D	.5D	.5D	.5D
X4, X7		.1625	.1875	.2125	.2375	.2625	.5D	.5D	.5D	.5D	.5D
X41, X71		.1938	.2188	.2438	.2688	.2938	.5D	.5D	.5D	.5D	.5D
X43, X73		.2250	.2500	.2750	.3000	.3250	.3438	.4063	.4688	.5313	.5D

Form Punch Shapes

Dayton Progress Form Punches are available on round punches (i.e., those designated as standard "X" shaped punches).

When ordering, change the "X" designator to a "W." In addition, specify other dimensions, as shown in

the example below. Specify alterations, if applicable. The shapes shown below are standard, but are not the only shapes Dayton provides. Others are available with a detailed drawing attached to the order.

Form Punches are also available on standard punch blanks. Form Punches other than those are available as specials.



FDS
FIRM DELIVERY SCHEDULE
1-19, 5 Days

HOW TO ORDER

Specify: Qty. Type Code L Steel W Shape P PP LA Alterations
Example: 2 VPW 37 1322 PS W201 P.1875 PP.1250 LA2.235 XNT

"P" is the point dimension of the product. The "P" dimensions are not shown below. When "P" = "D," shank tolerance applies.

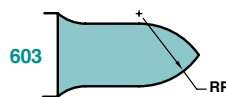
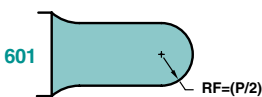
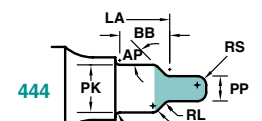
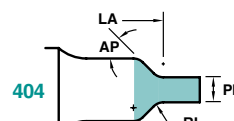
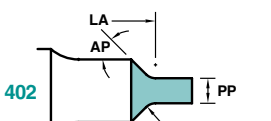
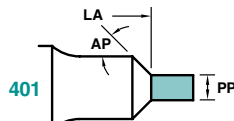
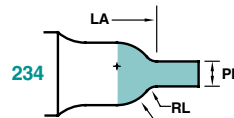
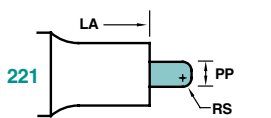
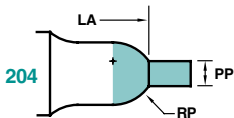
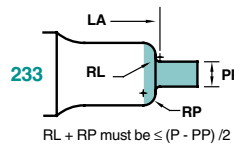
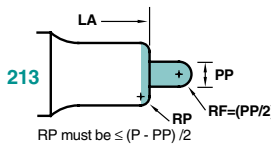
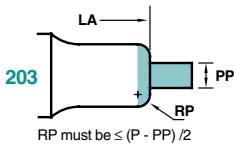
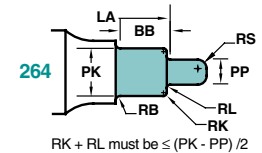
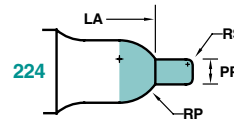
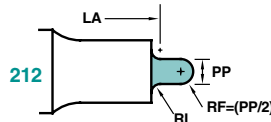
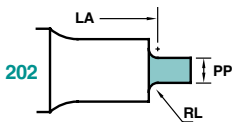
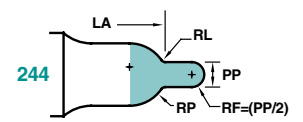
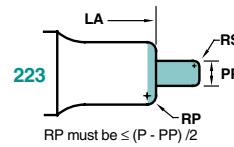
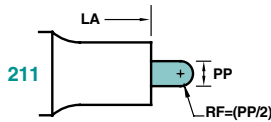
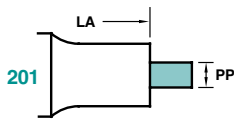
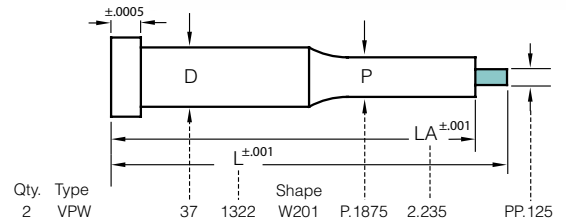

Form Punch Shapes

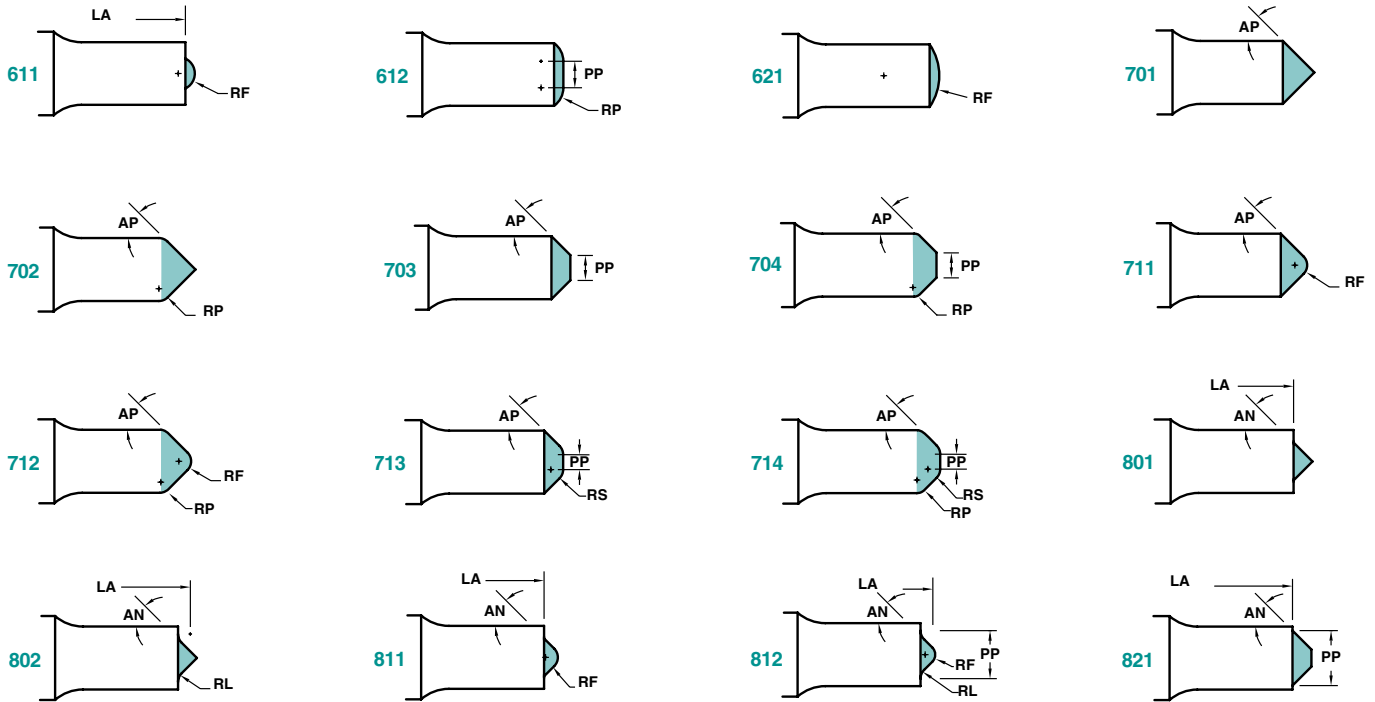

Form Die Button Shapes

Dayton Die Buttons are available for all the Form Punches shown here, i.e., round punches designated as standard "X" shaped punches. When ordering, please

change the "X" designator to a "W." Die Buttons are available as headed or headless with a counterbore relief, or as headed or headless with a tapered relief.



*B (Land Length) will be per catalog standard, unless XB is ordered. O.A.L. will be held to LL tolerance, i.e., ±.001.

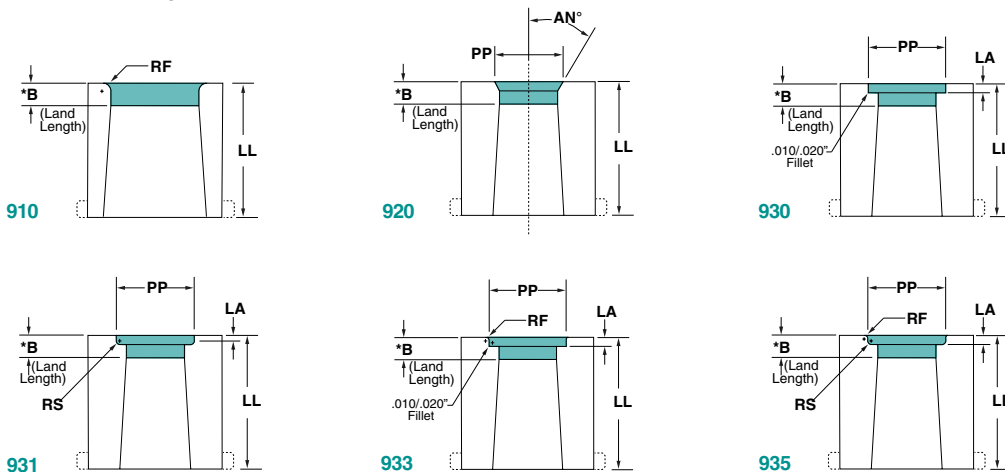

HOW TO ORDER

Specify:	Qty.	Type	Code	LL	Steel	W Shape	P	PP	LA	RS	RF	AN°	Alterations
Example:	4	VNW	100	100	M2	W935	.50	.625	.15	.05	.03		XNT

FDS
FIRM DELIVERY SCHEDULE
1-19, 5 Days

Jektole® Data

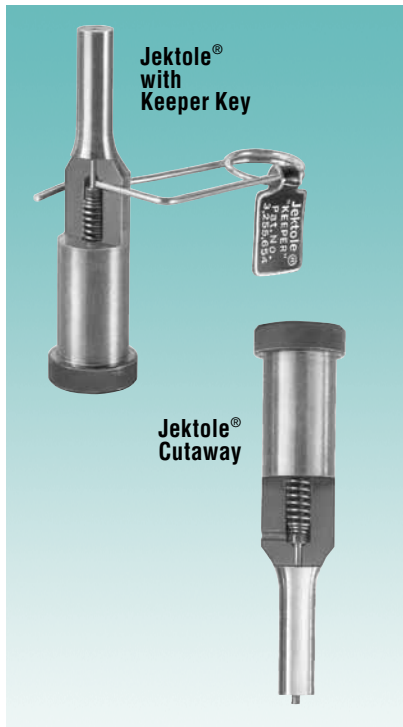

The Engineered Clearance

Perforating punch-to-die button clearances in metal stamping dies has been universally expressed as a percentage of stock thickness, and for clarity should be articulated as percent per side (Δ = clearance per side).

Standard practice has called for Δ 5%, and is commonly known as “regular clearance.” Regular clearance has been applied almost universally to all applications involving the perforation of ferrous materials.

Jektole®, the *Engineered Clearance*, is approximately twice regular clearance, i.e., Δ 10-12%. This means greater productivity, improved maintenance, and a better return on your tooling investment.

In addition, clearances of up to Δ 50% are not uncommon with some hard materials. Clearance tests have been performed by Dayton Progress to prove that increasing the clearance does not lessen hole quality—a common thought by some designers and engineers. Dayton clearance tests do, in fact, prove that the Jektole® *Engineered Clearance* provides many advantages and benefits.

Jektole® In Production

- Requires less press tonnage
- Reduces the pressure required to strip the punch, which, in turn, reduces punch wear
- Produces minimal burr
- Doubles—often triples—piece output per grind
- Reduces total punch costs

Jektole® In Maintenance

- Keeper Key holds pin in retracted position (see photo at left)
- Eliminates the need for disassembly before grinding
- Helps maintain proper pin extension
- Reduces downtime for regrinding

Standard Jektole® Data

DIMENSION	J2	J3	J4	J6	J9	J12
Std. Shank Diameter	D .1875	.2500	.3125	.3750 .4375 .5000	.6250 .7500 1.000	1.250 and larger
Point Hole Diameter	C .020	.032	.046	.063	.094	.125
Shank Hole Diameter	E .086	.109	.141	.172	.221	.275
Pin Extension	.03	.03	.06	.06	.06	.06
Keeper Key Number	920045			920053		*

* Keeper Key not available

Jektole® Design Limits

DIMENSION	J2	J3	J4	J6	J9	J12
Min. Shank Dia.	D .172	.218	.282	.344	.442	.552
Min. Point Dia.	P .040	.064	.092	.126	.188	.250
Max. Point Lgth.	B 1.25	1.50	1.62	1.62	1.62	1.62

Jektole® Components

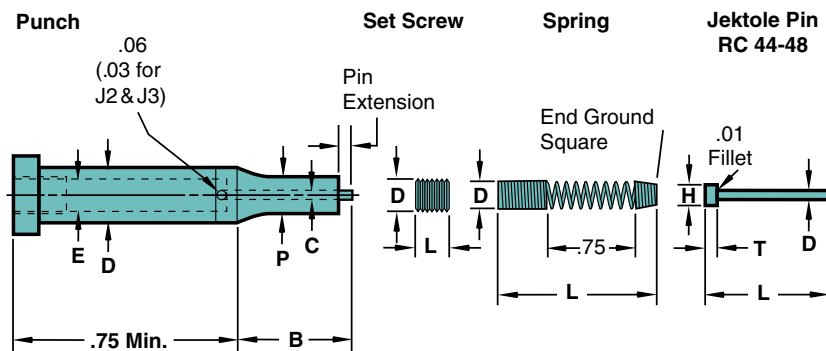

Universal Jektole® Components

EJECTOR PINS	J2	J3	J4	J6	J9	J12
Overall Length	L 1.11	1.38	1.94	1.94	2.22	2.22
Pin Diameter	D .017	.027	.041	.058	.089	.120
Head Diameter	H .048	.073	.094	.120	.156	.188
Hd. Thickness	T .031	.047	.062	.062	.094	.094
SPRINGS	J2	J3	J4	J6	J9	J12
Outside Dia.	D .081	.104	.136	.167	.216	.270
Free Length	L 2.38	2.38	3.19	3.00	3.03	2.56
Pressure (.12" Pre-load)	lbs. .5	.75	1	1.5	2	2.5
SCREWS	J2	J3	J4	J6	J9	J12
Screw Size	D #3-48	#5-40	#8-32	#10-32	1/4-28	5/16-24
Screw Length	L .19	.19	.19	.19	.25	.25

Commitment to Quality & Customer Satisfaction

Dayton Lamina is a leading manufacturer of tool, die and mold components for the metal-working and plastics industries. As a customer-focused, world-class supplier of choice, we provide the brands, product breadth, distribution network and technical support for all your metal forming needs.

Our goal is to give our customers the most innovative and value-added products and services.



DAYTON Lamina™

a MISUMI Group Company



IEM®



Lamina® LEMPCO®

*Dayton Lamina's line of Danly products is available only to North America.

www.daytonlamina.com