

GN 851.2 Latch Type Toggle Clamps

Steel, Vertical Mounting Base, Horizontal Clamping Arm

Photo



Product description

Information

The stroke of GN 851.2 latch type toggle clamps can be adjusted within its range.

In the clamped position the U-bolt latch and the clamping arm are horizontal to the vertical mounting plane.

In addition to the standard lengths of the U-bolt latches shown in the table, a variety of other lengths are also available under the GN 951.1 series.

Specification

Toggle clamp
Case-hardened steel C10
Zinc plated, blue passivated finish

U-bolt latch

- Steel St. 37
- Zinc plated, blue passivated finish

All moving parts lubricated with special grease

Hand grip
High quality, oil resistant, red plastic

RoHS compliant



Type: T4 - With U-bolt latch, with catch



Technical drawing

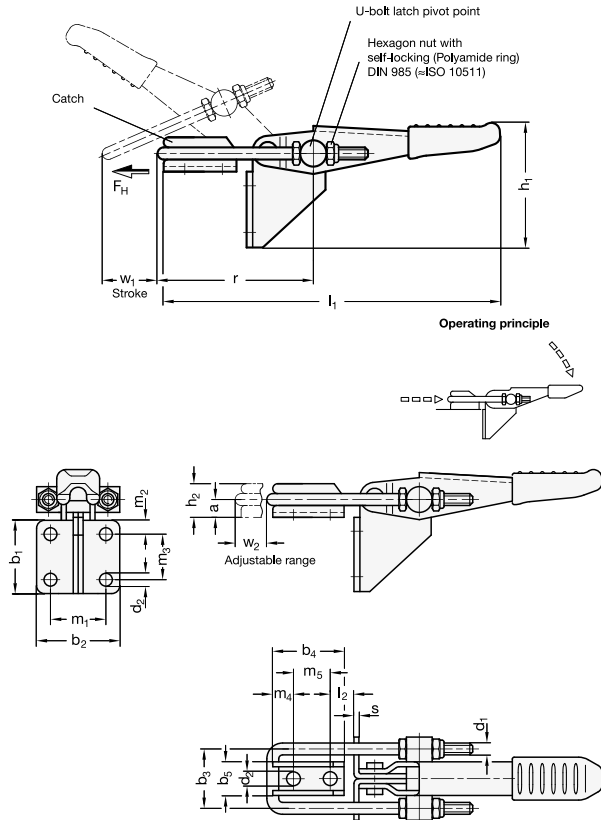

Part Options / Table

Type

T4	With U-bolt latch, with catch
T	Without U-bolt latch, with catch

Metric

Size	FH Holding capacity	a	b ₁	b ₂	b ₃	b ₄	b ₅	d ₁ Thread	d ₂	h ₁ ≈	h ₂
160	360 lbf (1600 N)	.20	1.02	1.38	.83	1.00	.55	M 4	.17	1.57	.39
320	719 lbf (3200 N)	.31	1.42	1.73	1.26	1.46	.87	M 6	.26	2.26	.59
700	1686 lbf (7500 N)	.51	2.05	2.13	1.50	1.91	1.02	M 8	.33	3.23	.91

Size	l ₁ ≈	l ₂ min.	m ₁	m ₂	m ₃	m ₄	m ₅	r ≈ at w ₂ = 0	s	W ₁ Stroke	W ₂ Adjustable range
160	4.09	.18	.87	.26	.51	.26	.56	1.97	.08	1.26	.47
320	6.26	.24	1.00	.33	.75	.41	.81	3.07	.12	2.09	.83
700	8.86	.31	1.44	.39	1.26	.53	1.06	3.86	.14	2.52	1.18