

GN 851 Horizontal Latch Type Toggle Clamps

Steel

Photo



Product description

Information

The stroke of the U-bolt latch of GN 851 latch type toggle clamps can be adjusted within its range.

The circular movement of the handle is transformed into linear action of the latch. These clamps are mostly used to fasten hinged lids on containers.

In the clamped position the U-bolt latch with clamping arm is parallel to the plane of the operating handle.

In addition to the standard lengths of the U-bolt latches shown in the table, a variety of other lengths are also available under the GN 951.1 series.

Specification

Toggle clamp
Case-hardened steel C10
Zinc plated, blue passivated finish

U-bolt latch steel St. 37
Zinc plated, blue passivated finish

All moving parts lubricated with special grease

Handle grip
High quality, oil resistant, red plastic

RoHS compliant



Type: T2 - With U-bolt latch, with catch



Technical drawing

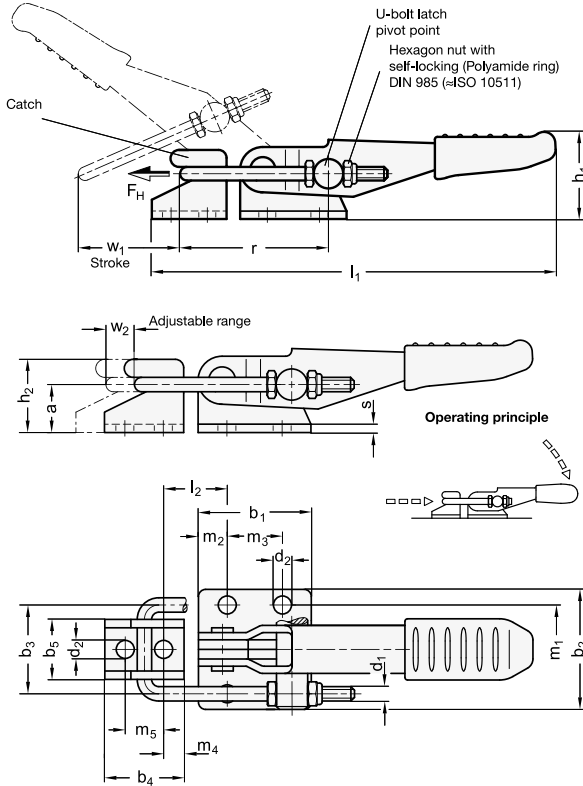

Part Options / Table

Type

T2	With U-bolt latch, with catch
T	Without U-bolt latch, with catch

Metric

Size	F_H Holding capacity	a	b_1	b_2	b_3	b_4	b_5	d_1 Thread	d_2	$h_1 =$	h_2
160	360 lbf (1600 N)	.47	1.02	1.10	.83	.79	.55	M 4	.17	1.02	.71
320	719 lbf (3200 N)	.63	1.57	1.73	1.26	1.10	.87	M 6	.26	1.18	.98
700	1686 lbf (7500 N)	.94	2.36	2.13	1.50	1.50	1.02	M 8	.33	1.65	1.42

Size	$l_1 =$	l_2 min.	m_1	m_2	m_3	m_4	m_5	$r =$ at $W_2 = 0$	s	W_1 Stroke	$W_2 =$ Adjustment Length
160	3.86	.43	.75	.20	.63	.20	.39	1.38	.08	.98	.43
320	5.98	.75	1.26	.41	.75	.28	.56	2.24	.12	1.89	.39
700	8.66	.83	1.50	.37	1.63	.37	.75	2.91	.14	2.28	.87