

2 Type
T With draw axle
TF With draw hook

Metric table



Dimensions in: millimeters - inches

Size	F _H Holding capacity	a ₁	a ₂	b ₁	b ₂	b ₃	d ₁	d ₂	d ₃	h ₁ ≈	h ₂
200	2000 N 450 lbf	37 1.46	29 1.14	35 1.38	45 1.77	18 .71	10 .39	8 .31	6.5 .26	49 1.93	16 .63
300	3000 N 674 lbf	35 1.38	25 .98	48 1.89	60 2.36	21 .83	10 .39	10 .39	8.5 .33	49 1.93	18 .71
400	4000 N 899 lbf	43 1.69	30 1.18	54 2.13	84 3.31	26 1.02	14 .55	12 .47	10.5 .41	60.5 2.38	25 .98

Size	l ₁ ≈	l ₂ ≈	l ₃ ≈	m ₁	m ₂	m ₃	r ₁ ≈	r ₂	s	w ₁ Stroke	w ₂ ≈ Adjustable range
200	202 7.95	51 2.01	93 3.66	32 1.26	8 .31	19 .75	102 4.02	5 .20	3 .12	100 3.94	20 .79
300	225 8.86	51 2.01	98 3.86	45 1.77	8 .31	32 1.26	105 4.13	6 .24	3 .12	104 4.09	20 .79
400	278 10.94	58 2.28	117.5 4.63	60 2.36	12.5 .49	28.5 1.12	138 5.43	7 .28	5 .20	160 6.30	20 .79

Specification

- Toggle clamp
Case hardened steel C10
Zinc plated, blue passivated finish
- Draw hook
Steel St 37
Zinc plated, blue passivated finish
- All moving parts lubricated with special grease
- Hand grip
High quality, oil resistant, red plastic
- RoHS compliant

Information

The draw hook of the GN 850 hook type toggle clamps can be adjusted within the stroke.
The circular movement of the handle is transformed into linear action of the latch. These clamps are mostly used to fasten hinged lids on containers.

see also...

- *General Information for Toggle Clamps*

<p>How to order</p> <p>GN 850-300-TF</p>	1 Size
	2 Type

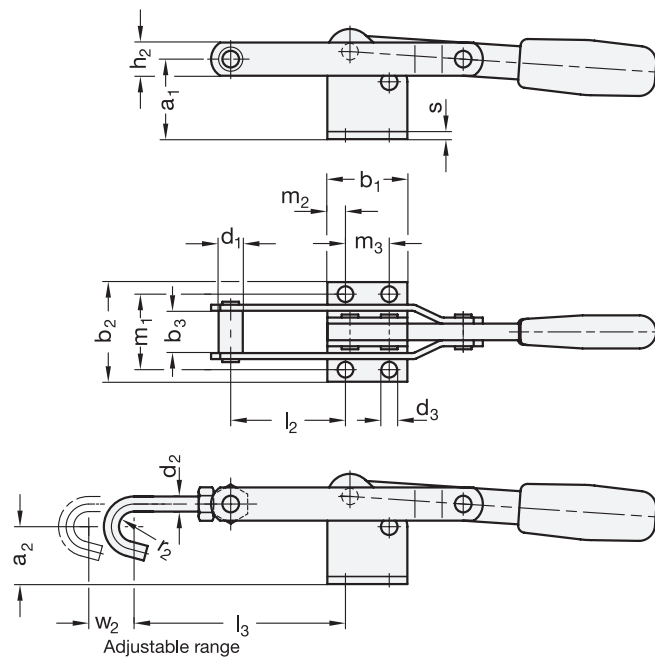

1.1

1.2

1.3

1.4

2.1

2.2

2.3

2.4

