

# GN 810

Steel / Stainless Steel

# Vertical Acting Toggle Clamps

with Horizontal Mounting Base



**JW WINCO**  
A Ganter Company

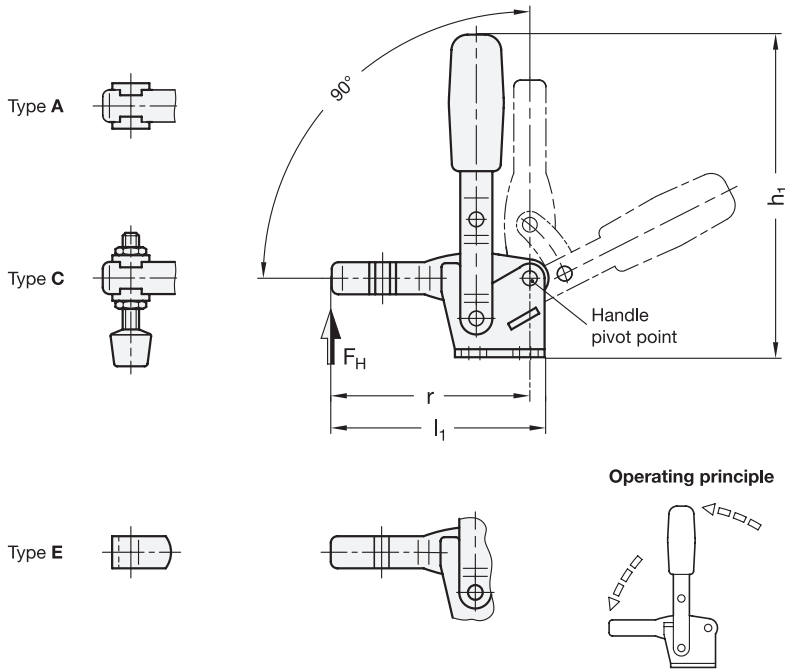

**SS** Stainless Steel

**2 Type**

- A** U-bar version, with two flanged washers
- C** U-bar version, with two flanged washers and GN 708.1 spindle assembly
- E** Solid bar version, with clasp

## Specification

- Toggle clamp  
Steel —
- Case hardened steel C10
- Zinc plated, blue passivated finish
- Tempered bearing pins
- Case hardened bearing rivets (for size 230 and up)
- Stainless steel **NI**  
European Standard No. 1.4301 (AISI 304)
- All moving parts lubricated with special grease
- Hand grip  
High quality, oil resistant red plastic
- Spindle assembly GN 708.1
  - Threaded stud  
Steel, zinc plated, blue passivated finish / Stainless steel  
European Standard No. 1.4301 (AISI 304)
  - Flat spindle tip (Type A)  
Black neoprene rubber (CR),  
85° shore A, vulcanized
- Mounting holes accommodate inch or metric size screws
- RoHS compliant

**3**

## Information

GN 810 vertical acting toggle clamps work according to the toggle principle: lever and clamping bar move in the same direction. In the clamped position the operating lever is in its vertical position.

Vertical acting toggle clamps in the U-bar version with two flanged washers (Type A) can accommodate an application specific clamping screw. A spindle assembly with neoprene rubber tip is also included for Type C.

Type E version can either be utilized by welding the clasp which can then accommodate an application specific hold-down fastener component, or by utilizing the bar in conjunction with the GN 809 clamp mounts to hold the work piece in place.

see also...

- *General Information for Toggle Clamps*
- *Heavy Duty Vertical Acting Toggle Clamps GN 910*
- *Vertical Acting Toggle Clamps GN 810.1 (with Vertical Mounting Base)*

## Accessory

- Spindle assemblies
- GN 801 clamp mounts (for Type A)
- GN 809 clamp mounts (for Type E)

How to order (Steel)	<b>1</b> Size
<b>GN810-75-E</b>	<b>2</b> Type

How to order (Stainless steel)	<b>1</b> Size
<b>GN810-75-A-NI</b>	<b>2</b> Type
	<b>3</b> Material

## Universal table



Dimensions in: millimeters - inches

Size	Steel	Stainless steel	F <sub>H</sub> Holding capacity	a ≈	b <sub>1</sub>	b <sub>2</sub>	b <sub>3</sub>	d <sub>1</sub> Thread	d <sub>2</sub> ≈	h <sub>1</sub> ≈	h <sub>2</sub>	h <sub>3</sub>	h <sub>4</sub>	h <sub>5</sub>
75	75	75	750 N 169 lbf	20 .79	29 1.14	34 1.34	5.2 .20	M 5	4.5 .18	98 3.86	20.5 .81	11 .43	19 .75	5.5 .22
130	130	130	1050 N 236 lbf	28 1.10	35 1.38	42 1.65	6.2 .24	M 6	5.5 .22	142 5.59	28 1.10	16 .63	25.5 1.00	11.3 .44
230	230	230	2000 N 450 lbf	40 1.57	43 1.69	45 1.77	8.5 .33	M 8	6.5 .26	168 6.61	33.5 1.32	18 .71	30 1.18	9.5 .37
330	-	-	2400 N 540 lbf	43 1.69	50 1.97	65 2.56	10.5 .41	M 10	8.5 .33	195 7.68	43 1.69	22 .87	37 1.46	15 .59
430	-	-	2800 N 629 lbf	64 2.52	58 2.28	65 2.56	12.5 .49	M 12	8.5 .33	247 9.72	55.5 2.19	26 1.02	43 1.69	23 .91
530	-	-	4500 N 1012 lbf	90 3.54	80 3.15	95 3.74	12.5 .49	M 12	12.5 .49	303 11.93	84.5 3.33	32 1.26	49 1.93	52 2.05

Size	Steel	Stainless steel	l <sub>1</sub> ≈	Type A Type C	Type E	l <sub>2</sub> ≈	l <sub>3</sub> max.	l <sub>4</sub>	m <sub>1</sub>	m <sub>2</sub>	m <sub>3</sub>	m <sub>4</sub>	r ≈	s <sub>1</sub>	s <sub>2</sub>	w	Adjustable range
75	75	75	66.5 2.62	67 2.64	67 2.64	31.5 1.24	41 1.61	45 1.77	15 .59	16 .63	24 .94	24 .94	62.5 2.46	2 .08	4 .16	15 .59	15 .59
130	130	130	85 3.35	86 3.39	86 3.39	42 1.65	54 2.13	55 2.17	12.5 .49	19 .75	27 1.06	29 1.14	79.5 3.13	2.5 .10	5 .20	17.5 .69	17.5 .69
230	230	230	110.5 4.35	112 4.41	112 4.41	58 2.28	73 2.87	68 2.68	19 .75	20 .79	32 1.26	32 1.26	104 4.09	3 .12	6 .24	20 .79	20 .79
330	-	-	129 5.08	130.5 5.14	130.5 5.14	66 2.60	86 3.39	77 3.03	29 1.14	32 1.26	45 1.77	46 1.81	122 4.80	3.5 .14	7 .28	19 .75	19 .75
430	-	-	164 6.46	166 6.54	166 6.54	88 3.46	114 4.49	100 3.94	32 1.26	32 1.26	45 1.77	45 1.77	156 6.14	4 .16	10 .39	33 1.30	33 1.30
530	-	-	223 8.78	225 8.86	225 8.86	125 4.92	152 5.98	100 3.94	50 1.97	51 2.01	70 2.76	70 2.76	212 8.35	7 .28	10 .39	27 1.06	27 1.06

