

GN 537 Fluid Level Sight Glasses

Aluminum, with Limit Indicator

Photo

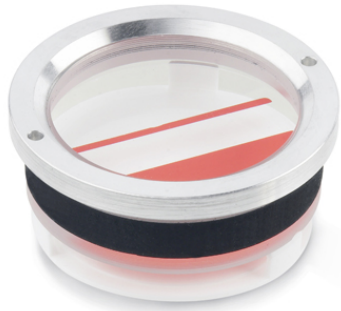

Product description

Information

No thread is required for installing the GN 537 fluid level sight glasses.

The fluid level sight glass is inserted into the bore d2, tolerance H11. By simply tightening the ring nut using the pin key, the seal is pressed against the contact surface which, at the same time, holds the sight glass in position.

For removal, reverse the procedure.

Application is limited to non-pressurized or slightly pressurized tanks.

Specification

Sight glass body

- Aluminum
-

Sight glass

- Plexiglas (PMMA)
 - temperature resistant up to 176° F (80° C)
-

Seal

- NBR synthetic rubber
-

Reflector

- White plastic with red fluid level limit indicators
-

Mounting

- Push-fit; use pin key for installation
-

RoHS compliant

Accessory

GN 537.1 Pin key

On request

Pin key for installation GN 537.1
(see table)

Technical drawing

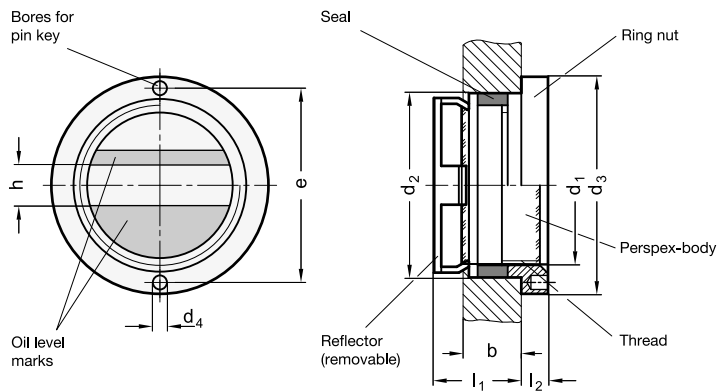

Part Options / Table

Type

A	without max. / min. oil level marks
B	with max. / min. oil level marks

Metric

d_1 Window glass	d_2 Bore-Ø	b min.	d_3	d_4	$e \pm 0.004$	h	l_1	l_2	Code no. Pin key for installation
.63	.79	.35	.98	.09	.83	.20	.59	.14	<u>21DRD0</u>
.87	1.10	.39	1.38	.12	1.18	.24	.59	.18	<u>30DRD0</u>
1.26	1.50	.47	1.77	.12	1.57	.31	.71	.22	<u>40DRD0</u>
1.97	2.28	.55	2.52	.12	2.30	.39	.87	.22	<u>59DRD0</u>