

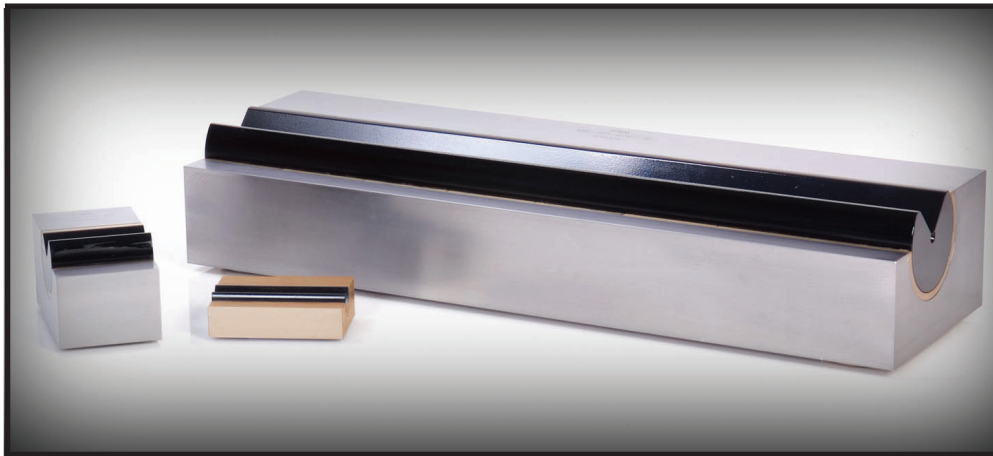

ACCU-BEND[™]

ACCU-BEND™

ACCU-BEND™ DESIGN AND MAINTENANCE RECOMMENDATIONS



INSIST ON AN ACCU-BEND™

To protect your Accu-Bend™ and for optimal performance, please remember the following:

- Use light oil (20W) before the first start-up.
- Clean and inspect the unit every 125k cycles. Re-lubricate with light oil (20W) before returning to service. NOTE: The 125k interval is a general service recommendation, and certain applications may require more or less maintenance.
- Clean the setscrew and use Loctite® 222 when reinstalling the set screw.
- Provide backup key to saddle.
- Use the proper method to modify a rocker for more over-bend (consult Anchor Lamina if assistance is needed). NEVER shim the Bender downward when attempting to create more over-bend.
- Provide over-bend back taper allowance in anvil.
- The groove in the anvil for the dart must allow for material thickness.
- The groove in the anvil for the dart must line up with the bender.
- Provide proper land for Z bend.
- Allow for material thickness tolerance when locating the saddle.
- Don't overstroke.

ACCU-BEND™ CONTENTS

	PAGE NUMBER
The Accu-Bend™ Advantage	1
How Accu-Bend™ Works	2
Standard Bender Specifications	3
Compact Bender Specifications	6
Bender Design Information	7
Modified Bends	8
Available Options	10
Accu-Bend™ Quotation Form	13

Accu-Bend™ Rotary Benders are manufactured in the USA.

Accu-Bend™ – Simplifying Your Bending Process!

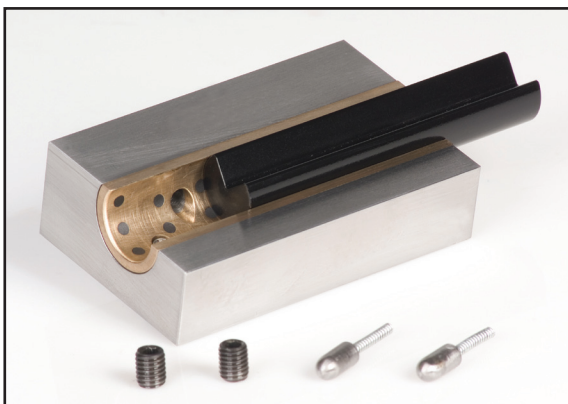

Product Features You Will Appreciate

The Accu-Bend™ is manufactured with the same precise methods and processes you put into your own designs. The saddle liner is a bronze alloy chosen for the ability to hold up to a bearing load with little to no wear.

The Flexibility To Handle Custom Orders

Having a wide range of standard sizes is never enough. When you have an application that calls for something special, call us. Our team of engineering specialists are waiting to tackle your job head-on. They will work with you to quickly find solutions that fit your specific application.

Once designed, making your custom order(s) will be quick and efficient, using our extensive production resources which utilize the latest in tooling.

How Accu-Bend™ Works

Product Features

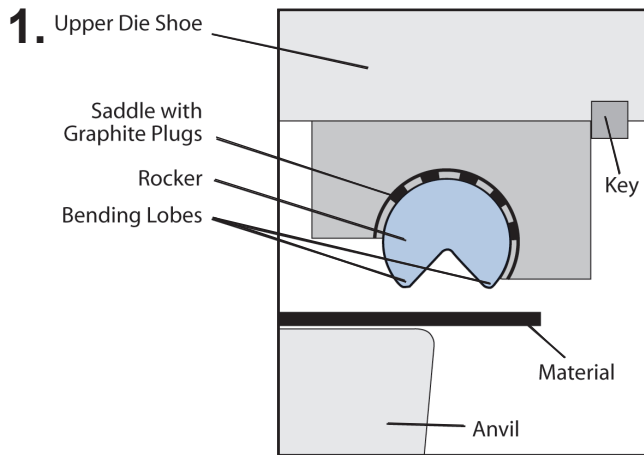

START POSITION

Downward pressure of the press clamps the part with the rocker's bending lobes before the bending action starts.

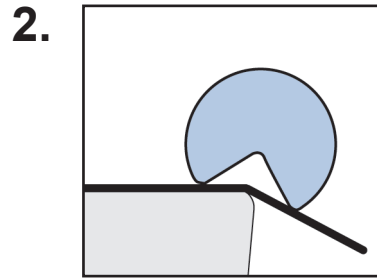

BEND

The rocker's rotation forms the material around the anvil with less pressure and material distortion than wipe bending.

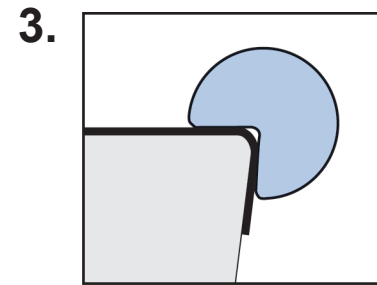

OVERBEND by 3°

Bending action continues to form the material around the anvil until desired angle is completed. The anvil should have 5° relief to allow for the 3° overbend.*

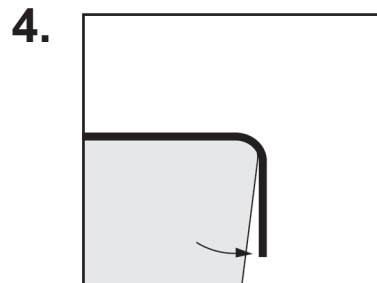

MATERIAL SPRINGBACK

Rocker bends past 90° to compensate for material springback, leaving a 90° bent part ($\pm 1/2^\circ$).

**The 3° overbend applies to cold rolled steel only.*

CUSTOM ORDERS:

- ◆ Requests for custom orders can be made by completing a Special Request Quote Form (page 13) or contacting Customer Service.
- ◆ Shorter lengths or segmenting are possible.
- ◆ Pressure pads can be ordered with Accu-Bend™ units.

FEATURES:

- ◆ 87° rocker for 90° bends. This allows a 3° overbend for material spring back.
- ◆ Rockers and saddles are precision machined.
- ◆ Graphite plugs are included in the bronze saddle liner to provide lubrication.

MATERIALS THAT CAN BE BENT:

- ◆ Hot Rolled Steel
- ◆ Cold Rolled Steel
- ◆ Dual Phase Steel (DP590, DP780, DP980)
- ◆ High Strength Low Alloy Steel
- ◆ Advanced High Strength Steel
- ◆ Ultra High Strength Steel
- ◆ Stainless Steel
- ◆ Galvanized Steel
- ◆ Aluminum
- ◆ Pre-painted Aluminum
- ◆ Brass
- ◆ Copper
- ◆ And Much More!

Standard Bender Specifications

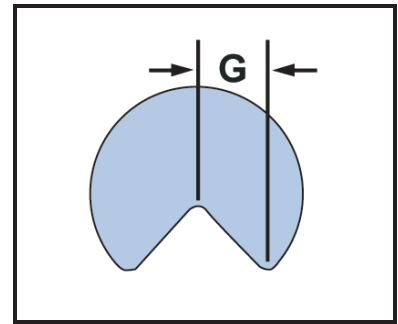
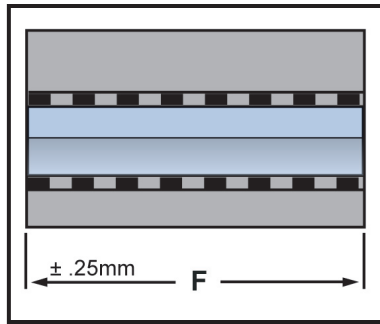
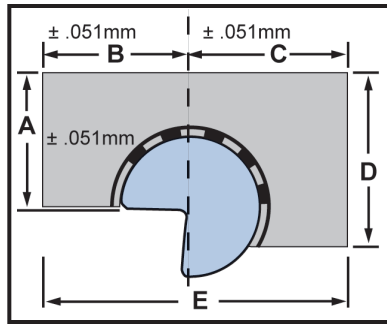

Model Number	Max. Part Thickness mm (in)	Minimum Part Height mm (in)	A mm (in)	B mm (in)	C mm (in)	D mm (in)	E mm (in)	F mm	F (in)	G mm (in)	Bolt for Mounting
MB-20-50	1.2 (0.05)	8.5 (0.33)	24 (0.94)	25 (0.98)	35 (1.38)	30 (1.18)	60 (2.36)	50	1.97	6.5 (0.26)	M6
MB-20-100								100	3.94		
MB-20-150								150	5.91		
MB-20-200								200	7.87		
MB-20-250								250	9.84		
MB-20-300								300	11.81		
MB-20-400								400	15.75		
MB-20-500								500	19.69		
MB-25-75	2 (0.08)	10 (0.39)	30 (1.18)	30 (1.18)	45 (1.77)	38 (1.50)	75 (2.95)	75	2.95	8.5 (0.33)	M6
MB-25-150								150	5.91		
MB-25-225								225	8.86		
MB-25-300								300	11.81		
MB-25-375								375	14.76		
MB-25-450								450	17.72		
MB-25-525								525	20.67		
MB-25-600								600	23.62		
MB-35-75	3 (0.12)	14 (0.55)	40 (1.57)	38 (1.50)	60 (2.36)	51 (2.01)	98 (3.86)	75	2.95	11.5 (0.45)	M8
MB-35-150								150	5.91		
MB-35-225								225	8.86		
MB-35-300								300	11.81		
MB-35-375								375	14.76		
MB-35-450								450	17.72		
MB-35-525								525	20.67		
MB-35-600								600	23.62		
MB-40-75	3.5 (0.14)	17 (0.67)	48 (1.89)	40 (1.58)	58 (2.28)	60 (2.36)	98 (3.86)	75	2.95	12.9 (0.51)	M8
MB-40-150								150	5.91		
MB-40-225								225	8.86		
MB-40-300								300	11.81		
MB-40-375								375	14.76		
MB-40-450								450	17.72		
MB-40-525								525	20.67		
MB-40-600								600	23.62		

NOTES:

- ◆ Dimension A is to center of rocker. Saddle is 0.10 – 0.15mm above.
- ◆ The MB-20 and MB-25 series benders have an S7 rocker that sits in a self-lubricating, bronze saddle.
- ◆ Material thickness capacity is based on 50KSI yield strength.
- ◆ All Accu-Bend™ units are made-to-order

Standard Bender Specifications *(continued)*

Model Number	Max. Part Thickness mm (in)	Min. Part Height mm (in)	A mm (in)	B mm (in)	C mm (in)	D mm (in)	E mm (in)	F mm	F (in)	G mm (in)	Bolt for Mounting
MB-50-75	4.5 (0.18)	20 (0.79)	55 (2.17)	50 (1.97)	76 (2.99)	70 (2.76)	126 (4.96)	75	2.95	16.5 (0.65)	M10
MB-50-150								150	5.91		
MB-50-225								225	8.86		
MB-50-300								300	11.81		
MB-50-375								375	14.76		
MB-50-450								450	17.72		
MB-50-525								525	20.67		
MB-50-600								600	23.62		
MB-50-750								750	29.53		
MB-65-75	6 (0.24)	25.5 (1.00)	70 (2.76)	60 (2.36)	92 (3.62)	90 (3.54)	152 (5.98)	75	2.95	21.5 (0.85)	M12
MB-65-150								150	5.91		
MB-65-225								225	8.86		
MB-65-300								300	11.81		
MB-65-375								375	14.76		
MB-65-450								450	17.72		
MB-65-525								525	20.67		
MB-65-600								600	23.62		
MB-65-750								750	29.53		
MB-65-900	900	35.43									
MB-80-75	7.5 (0.30)	31.5 (1.24)	80 (3.15)	70 (2.76)	105 (4.13)	105 (4.13)	175 (6.89)	75	2.95	26.5 (1.04)	M12
MB-80-150								150	5.91		
MB-80-225								225	8.86		
MB-80-300								300	11.81		
MB-80-375								375	14.76		
MB-80-450								450	17.72		
MB-80-525								525	20.67		
MB-80-600								600	23.62		
MB-80-750								750	29.53		
MB-80-900	900	35.43									
MB-100-100	8.5 (0.33)	47 (1.85)	96 (3.77)	85 (3.34)	120 (4.72)	126 (4.96)	205 (8.07)	100	3.94	32.8 (1.29)	M12
MB-100-200								200	7.87		
MB-100-300								300	11.81		
MB-100-400								400	15.75		
MB-100-500								500	19.69		
MB-100-600								600	23.62		
MB-100-700								700	27.56		
MB-100-800								800	31.50		
MB-100-900								900	35.43		
MB-115-100	9.5 (0.37)	52 (2.04)	100 (3.93)	90 (3.54)	127 (5.00)	135 (5.31)	217 (8.54)	100	3.94	37.1 (1.46)	M12
MB-115-200								200	7.87		
MB-115-300								300	11.81		
MB-115-400								400	15.75		
MB-115-500								500	19.69		
MB-115-600								600	23.62		
MB-115-700								700	27.56		
MB-115-800								800	31.50		
MB-115-900								900	35.43		

NOTES:

- ◆ Dimension A is to center of rocker. Saddle is 0.10 – 0.15mm above.
- ◆ The MB-20 and MB-25 series benders have an S7 rocker that sits in a self-lubricating, bronze saddle.
- ◆ Material thickness capacity is based on 50KSI yield strength.
- ◆ All Accu-Bend™ units are made-to-order

Standard Bender Specifications *(continued)*

Bender Load Capacity

Bender Diameter mm	LBS. per Inch Length	KGS per 25mm Length
20	750	340
25	1450	660
35	2300	1050
40	2750	1250
50	3600	1650
65	4800	2200
80	6000	2750
100	6400	2860
115	7100	3170

NOTES:

- ◆ Use formula on pg.7 to match bender size to other material strength and thickness.

Compact Bender Specifications

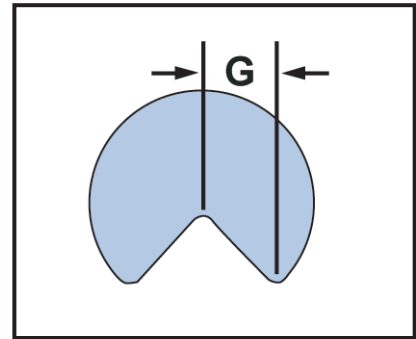
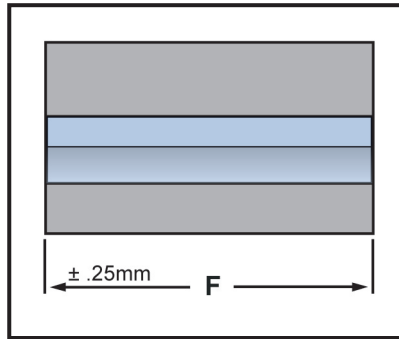
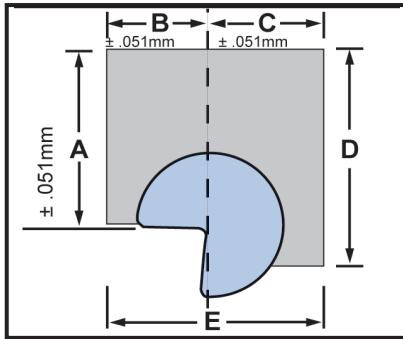

Model Number	Max. Part Thickness mm (in)	Minimum Part Height mm (in)	A mm (in)	B mm (in)	C mm (in)	D mm (in)	E mm (in)	F mm	F (in)	G mm (in)	Bolt for Mounting
CMB-20-50	1.2 (0.05)	8.5 (0.33)	48 (1.89)	18 (0.71)	18 (0.71)	54 (2.13)	36 (1.42)	50	1.97	6.5 (0.26)	M6
CMB-20-100								100	3.94		
CMB-20-150								150	5.91		
CMB-25-50	2 (0.08)	10 (0.39)	60 (2.36)	20 (0.79)	20 (0.79)	68 (2.68)	40 (1.57)	50	1.97	8.5 (0.33)	M6
CMB-25-100								100	6.94		
CMB-25-150								150	5.91		
CMB-35-50	3 (0.12)	14 (0.55)	74 (2.91)	25 (0.98)	25 (0.98)	85 (3.35)	50 (1.97)	50	1.97	11.5 (0.45)	M8
CMB-35-100								100	3.94		
CMB-35-150								150	5.91		
CMB-50-50	4.5 (0.18)	20 (0.79)	85 (3.35)	35 (1.38)	35 (1.38)	100 (3.94)	70 (2.76)	50	1.97	16.5 (0.65)	M10
CMB-50-100								100	3.94		
CMB-50-150								150	5.91		
CMB-65-50	6 (0.24)	26 (1.02)	100 (3.94)	45 (1.77)	45 (1.77)	120 (4.72)	90 (3.54)	50	1.97	21.5 (0.85)	M12
CMB-65-100								100	3.94		
CMB-65-150								150	5.91		

NOTES:

- ◆ Dimension A is to center of rocker. Saddle is 0.10 – 0.15mm above.
- ◆ All compact (CMB) series benders have an S7 rocker that sits in a self-lubricating, bronze saddle.
- ◆ Material thickness capacity is based on 50KSI yield strength.
- ◆ All Accu-Bend™ units are made-to-order

Bender Design Information

Bender Location

- ◆ Use the formula for setting the “K” dimension for a 90° bend using a standard 87° rocker. Proper setting of the rocker centerline in relation to the anvil radius centerline is important for dimensioning the key slots needed to hold the backup key.

$$K = \frac{(PT + R)}{\tan(43.5^\circ)}$$

The “K” dimension for over bend or under bend applications is best determined by doing a CAD layout.

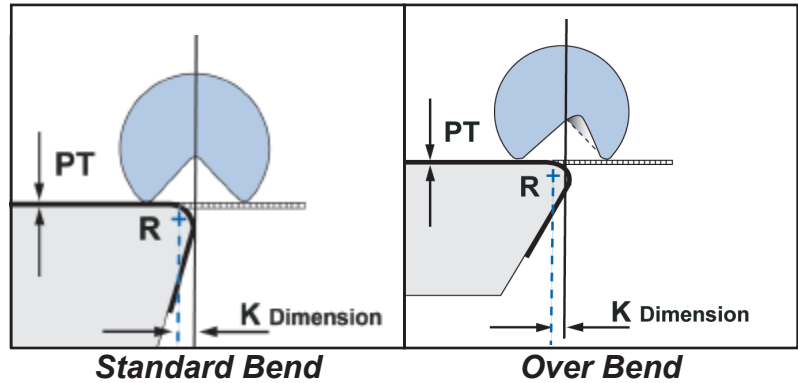

Force Formula for the Accu-Bend™

- F = Force Required (Pounds)
- UTS = Ultimate Tensile Strength
- W = Width of Bend, inch
- PT = Part Thickness, inch
- G = Rocker Dimension, inch
- R = Part Radius (inside), inch

$$F = 2.25 \times \frac{UTS \times W \times (PT)^2}{G + PT + R}$$

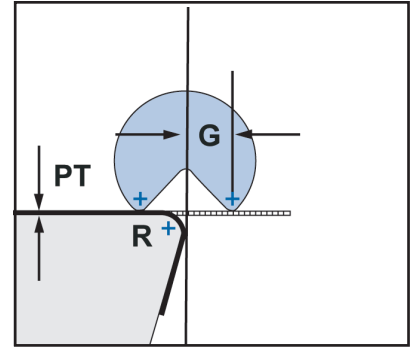

General Bend Allowance

The smooth rotary action of a bender requires a greater bend allowance than is typical with a coining or wipe bending operation. The formula for the bend allowance is:

$$BA = 0.01745 \times (180 - PA) \times [R + (PT \times .43)]$$

Important: Variances in material specifications and tolerances may require a change in the bend allowance when changing coils of the same material or changing material type altogether.

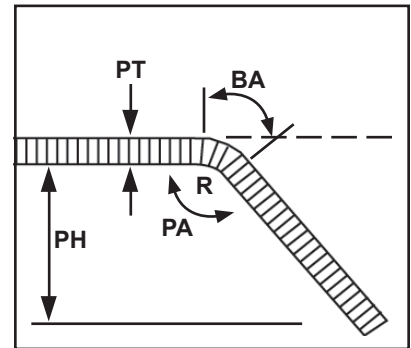

Pad Functions

- ◆ Eliminates contact marks on clamped surfaces.
- ◆ Protects cutout or hole from distortion.
- ◆ Matches preformed shape.
- ◆ Used for extreme overbend.
- ◆ Prevents humping of material when using an over sized bender.
- ◆ Used to match a standard rocker radius to Zee Bend dimension.
- ◆ Pad can usually be integral to the bender.

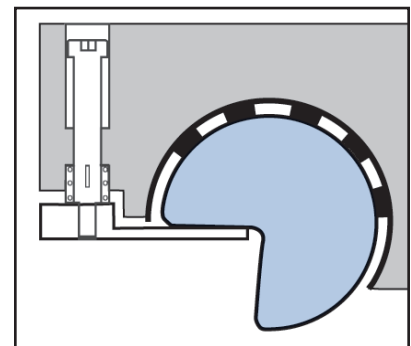

Modified Bends

Channel Bend and Hat Bends – Paired Units

- ◆ Channel bends can be accomplished in one press stroke by pairing two benders face-to-face.
- ◆ In order to use standard benders, the spread or part channel must be greater than 2 times the (B) dimension.
- ◆ The rocker inside radius can be specially matched if required. Use a set of interlaced benders for a channel less than $2 \times B$.
- ◆ A pressure pad may be required to hold the part to keep the material from humping at the bend radius and in place.
- ◆ Hat bends can be handled with a two Zee Bend setup.

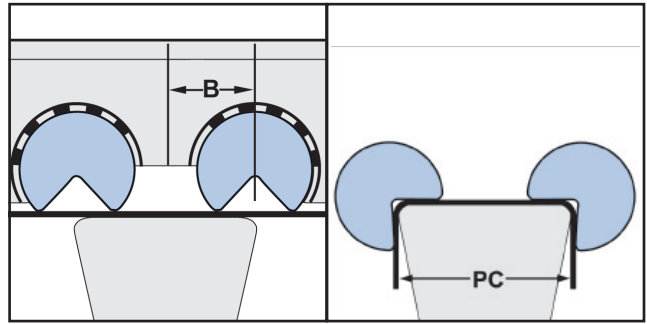

Channel Bend and Hat Bends

- ◆ For narrow channel and hat bends in one hit.
- ◆ Each unit has an integral pad.

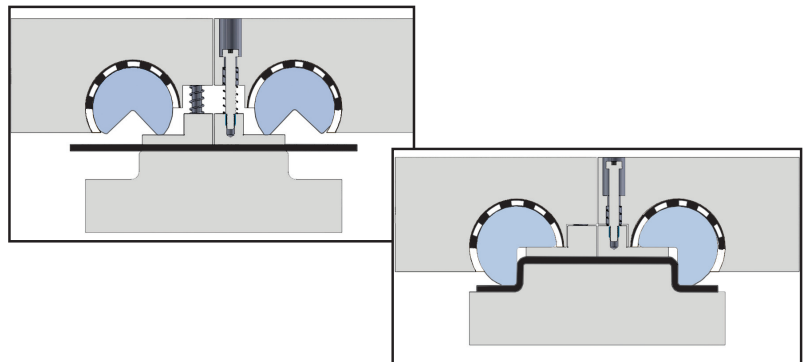

Interlaced Benders

- ◆ Custom interlacing to channel dimension.
- ◆ Forms a narrow channel in one hit.

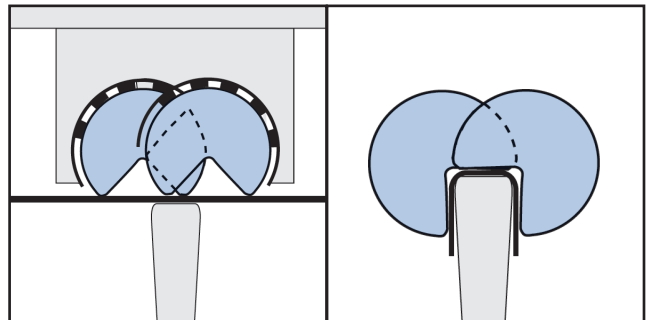

Large Radius

- ◆ A bend radius exceeding 3 times part thickness is considered a large radius bend.
- ◆ Large radius bends can be accomplished by using a larger size rocker.
- ◆ Adding a few extra degrees of over bend is required to compensate for material spring back.
- ◆ Under certain circumstances, the rocker's inside radius can be specifically matched to the part radius.

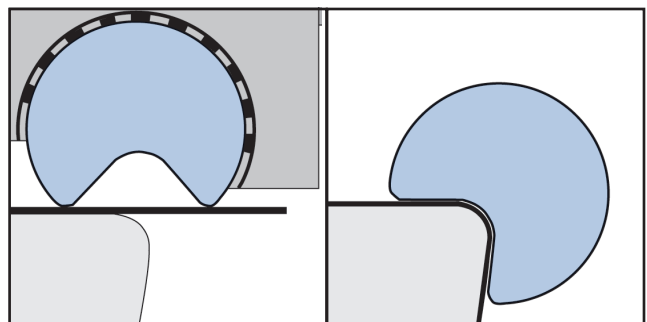

Modified Bends *(continued)*

Short Leg

- ◆ Short leg bends require a recessed step in the bending lobe of the rocker to accommodate the shorter part height.
- ◆ Tonnage requirements will increase as compared to a standard bend.
- ◆ The formula to determine the shortest leg possible is:
 $2.6 \times (\text{part thickness}) + (\text{part radius})$.

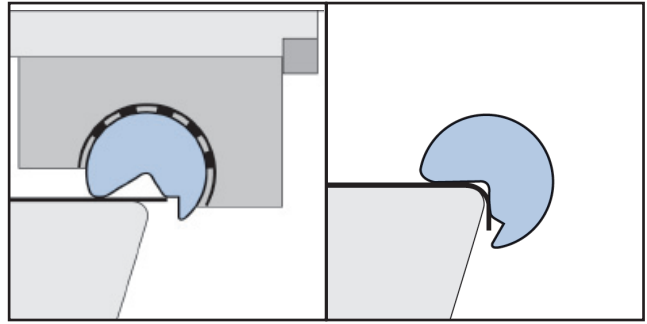

Over Square (up to 120°)

- ◆ Over square bends require a modification of the rocker angle while maintaining a constant bending lobe radius.
- ◆ The use of a pressure pad is suggested for over square bends over 110° to keep the rocker from sticking to the part.

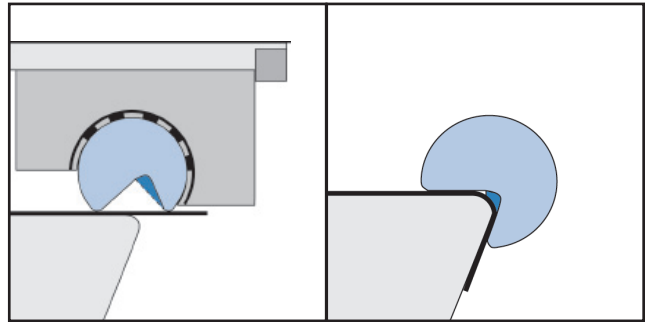

Under Square

- ◆ Part angle over 105°, bender centerline above part.
- ◆ Part angle up to 105°, bender centerline on part.

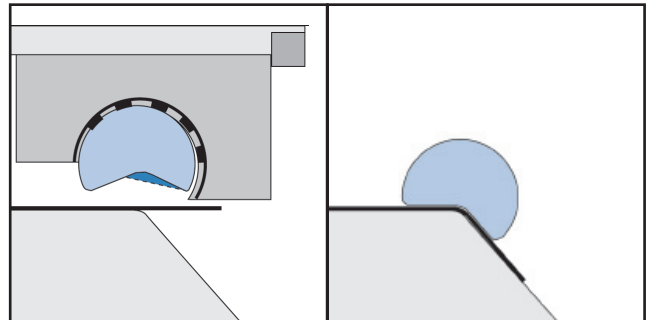

Zee Bend

- ◆ A true 90° rocker is used in Zee Bend applications.
- ◆ A pressure pad is usually required to make up the difference between the part height and the (I) dimension of the rocker.
- ◆ A slight modification to the bending lobe at the time of production of the bender may be required to obtain the desired part radius on the lower bend.

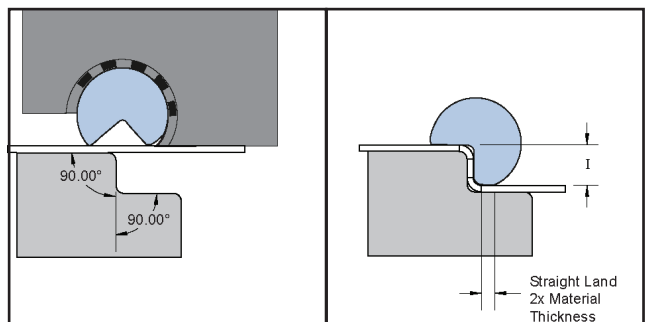

Available Options

Counter Bored Mounting Holes – Standard

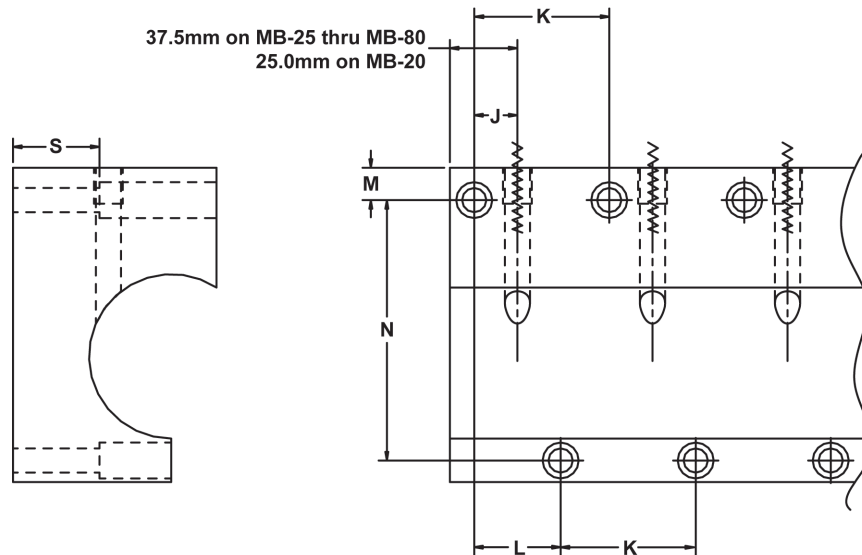

COUNTER BORED MOUNTING HOLES

	Model Number	Bolt	S mm in	J mm in	K mm in	L mm in	M mm in	N mm in
METRIC	MB-20	M6	16	16	50	32	9	45
	MB-25	M6	24	18	75	36	9	59
	MB-35	M8	30	22	75	44	12	78
	MB-40	M8	38	22	75	44	12	78
	MB-50	M10	40	22	75	44	15	101
	MB-65	M12	25	24	75	48	18	123
	MB-80	M12	40	24	75	48	18	145
	MB-100	M12	82.5	30	100	60	20	170
INCH	MB-115	M12	86.5	30	100	60	20	185
	MB-20	1/4	0.625	0.75	2	1.5	0.25	1.875
	MB-25	1/4	.75	0.75	2.875	1.5	0.3125	2.375
	MB-35	5/16	1.125	0.875	2.875	1.75	0.5	3.0
	MB-40	5/16	1.5	0.875	2.875	1.75	0.55	3.0
	MB-50	3/8	1.5	0.875	2.875	1.75	0.6875	3.875
	MB-65	1/2	1.0	1.0	2.875	2.0	0.8	4.75
	MB-80	1/2	1.5	1.0	2.875	2.0	0.75	5.625
MB-100	1/2	3.875	1.25	3.875	2.5	0.75	6.75	
MB-115	1/2	3.375	1.25	3.875	2.5	0.75	7.25	

NOTES:

- ◆ When ordering with mounting holes, specify Metric, Inch or Customer specified on the Accu-Bend™ quotation form, located in the back of the catalog.

Available Options *(continued)*

Threaded Mounting Holes – Compact

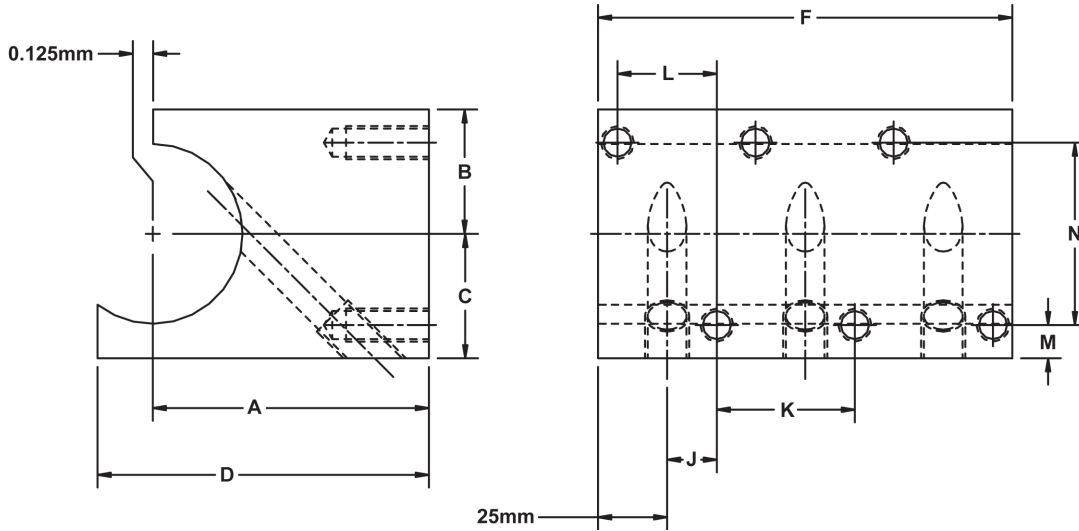

THREADED MOUNTING HOLES

	Model Number	Bolt	Depth of Tap mm in	J mm in	K mm in	L mm in	M mm in	N mm in	Bolts for Mounting
METRIC	CMB-20	M6	15	15	50	30	6	24	M6 x 1
	CMB-25	M6	15	15	50	30	6	28	M6 x 1
	CMB-35	M8	20	18	50	36	8	34	M8 x 1.25
	CMB-50	M10	25	18	50	36	10	50	M10 x 1.5
	CMB-65	M12	30	18	50	36	12	66	M12 x 1.75
INCH	CMB-20	1/4	0.625	0.5	2	1.125	0.25	0.875	1/4 – 20
	CMB-25	1/4	0.625	0.5	2	1.125	0.25	1.125	1/4 – 20
	CMB-35	5/16	0.75	0.5	2	1.125	0.375	1.375	5/16 – 18
	CMB-50	3/8	1	0.5	2	1.125	0.4	2	3/8 – 16
	CMB-65	1/2	1.125	0.5	2	1.125	0.5	2.625	1/2 – 13

NOTES:

- ◆ When ordering with mounting holes, specify Metric, Inch or Customer specified on the Accu-Bend™ quotation form, located in the back of the catalog.

Available Options *(continued)*

Composite Insert

- ◆ The composite material is a hard, low-friction polymer used as a contact material for stainless or pre-painted steel where slight tool marks are not acceptable.
- ◆ Tool marks can be eliminated by using a composite insert in combination with a pressure pad positioned between the part surface and the bending lobe of the rocker.
- ◆ Composite inserts are not available in the MB-20 and CMB-20 models.

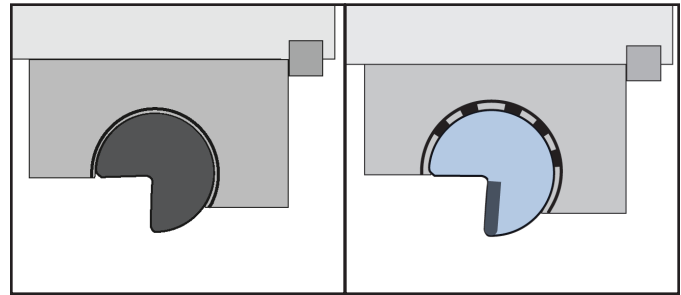

Dart Stiffener

- ◆ Dart Stiffeners are an easy way to add strength to any part and are formed using less tonnage with the rotary action of the Accu-Bend™.
- ◆ You can specify the size of the dart and a rocker with built-in dowel(s) will be made to fit your application.
- ◆ A relief in the anvil is necessary to accommodate each dart.

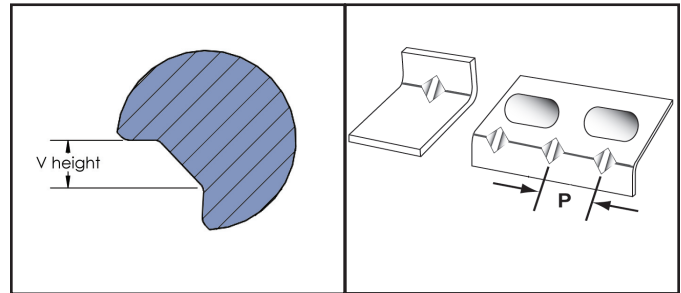

Standard "V"

Bender Diameter mm	Dowel Diameter mm	Gusset Height mm
20	3	5
25	4	8
35	6	10
40	7	11
50	8	12
65	10	12
80	12	12

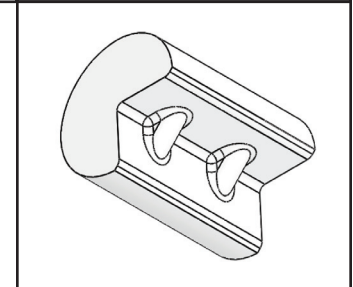

ACCU-BEND™ QUOTATION FORM

Quote Number _____ Date: _____

COMPANY INFORMATION







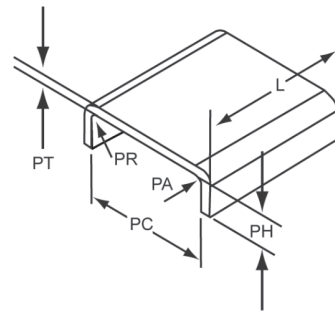

Company Name: _____
 Contact: _____ Title: _____
 Address: _____
 City: _____ State: _____ Zip: _____
 Phone: _____ Fax: _____
 E-mail Address: _____

APPLICATION INFORMATION

Production Method:¹ Stamping Press Press Brake
 Order Quantity: _____ Material Type & Grade: _____
 Material Yield Strength: _____ Ann. Prod. Volume: _____
 L = Length of Bend (bender length): _____ PT = Part Material Thickness: _____
 PH = Part Height (bent leg): _____ PR = Part Radius (inside):³ _____
 PC = Part Channel (inside): _____ PA = Part Angle (inside): _____
 Over Bend required (30° max):² _____
 Check here if you are interested in test bending this part
 No. of drawings attached: _____
 Check here if tool marks are not acceptable
 Mounting hole options: Metric Inch Customer specified



Type of Bend (check one)

Square		<input type="checkbox"/>	Zee Bend		<input type="checkbox"/>
Over Square		<input type="checkbox"/>	Short Leg		<input type="checkbox"/>
Channel		<input type="checkbox"/>	Under Square		<input type="checkbox"/>
Hat Bend		<input type="checkbox"/>	"J" Bend (requires two hits)		<input type="checkbox"/>

1. Press brake application will require special mounting plates and special heeling to secure the Accu-Bends™.
2. If the over bend angle is not specified by the customer, we will recommend the over bend required. However, this recommendation is not a guarantee. A variety of test bending can be performed. Please contact Customer Service regarding our test bending service. Send CAD data to info@anchorlamina.com.
3. Due to material characteristics, it is recommended that the part radius should be at least equal to the material thickness. The final part radius is a result of anvil geometry and material behavior.

FAX: 248-553-6842 or 800-406-4410

Commitment to Quality & Customer Satisfaction

Dayton Lamina is a leading manufacturer of tool, die and mold components for the metal-working and plastics industries. As a customer-focused, world-class supplier of choice, we provide the brands, product breadth, distribution network and technical support for all your metal forming needs.

Our goal is to give our customers the most innovative and value-added products and services.



DAYTON Lamina™

a MISUMI Group Company



Lamina® LEMPCO

*Dayton Lamina's line of Danly products is available only to North America.

www.daytonlamina.com