

## LAMCAM<sup>™</sup> VERSION 6



- More Spring Return Options
- Higher Pressure for Stripping

 **LamCam**<sup>®</sup> – Diemount Cams

[www.daytonlamina.com](http://www.daytonlamina.com)  
Check our website for the  
latest technical information.

## TABLE OF CONTENTS

Introduction.....	2
General Information.....	3
SlimCam™ NLD Series.....	4
50 Series Cams.....	8
75 Series Cams.....	12
125-150 Series Cams.....	16
175-200 Series Cams.....	20
250-300 Series Cams.....	24
Installation Instructions.....	28

Anchor Lamina has made a commitment to the metal stamping industry by manufacturing and distributing a comprehensive collection of high quality products.

Lamina has long been known for expertise in producing precision products and has applied that knowledge into the design and production of cams with truly interchangeable parts. LamCams maintain consistency throughout standard lines available from bump cams to Aerial and Diemount cams to large Modular Style Cams.

Input from our customers has been and continues to be an important part of cam development and maintenance which assures Lamina's leadership position.

No other company surpasses our obligation to you, our customer, in supporting cam products. We listen to your needs and respond when you require our assistance.

- Ease of spring replacement from back of cam; the cam base incorporates a safety restraint system to retain the slide during spring removal
- High quality materials used throughout, including high-strength steel castings for major components
- All wear areas are double-plated with self-lubricated wear plates to reduce maintenance and accommodate high production volumes
- Four Return Spring Kit Options are available: mechanical ISO spring, combination mechanical/nitrogen springs, nitrogen spring and high force nitrogen
- Pentahedron design ensures smooth and stable slide movement on 125 through 300 Series Cams
- Dual external positive return system; Urethane bumper cushion on slide return
- Mounting/locating provisions include both square keys and dowel holes
- Meets or exceeds all of "NAAMS" cam requirements
- Lock-out kit installed, ready for cam installation and set up
- Safety backup provisions for retaining keeper plates
- *Improved, super-duty* accelerator system standard on 0° through 30° angles
- Optional hydraulic shock absorber available

## SLIDE RETURN SYSTEM OPTIONS

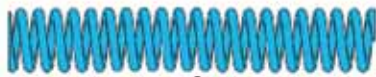

Mechanical Spring



Mechanical & Nitrogen Spring\*



Nitrogen Spring &  
Higher Force Nitrogen Spring

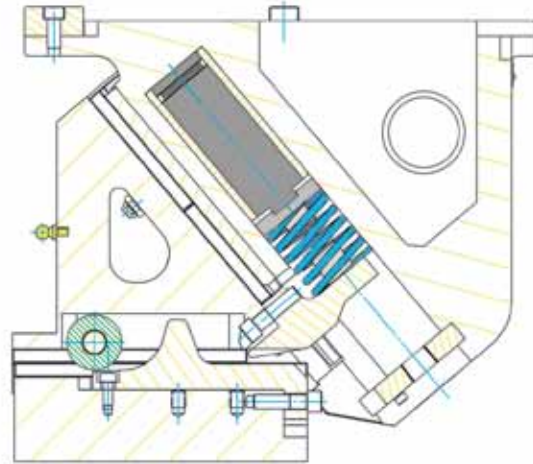

Recognizing that different cam applications have different requirements, Lamina offers four Return Spring Kit Options.

1. **Mechanical** – Employs a conventional ISO Die Spring, used in cam applications where additional stripping force is not required.
2. **Combination Mechanical/Nitrogen** – This unique Lamina design employs an ISO Die Spring in series combination with a Nitrogen Spring. This return system utilizes the mechanical spring for preload, keeping the initial contact forces low, while providing high final loads from the nitrogen spring for part stripping.
3. **Nitrogen** – This return system provides high return spring forces for stripping. By nature of the nitrogen spring, it also has a higher initial contact force than other return spring options. This higher contact force may result in greater wear on the cam and its accelerator system (where applicable).
4. **Higher Force Nitrogen** – Fits the standard gas spring envelope, and delivers more force for stripping.

**\*Lamina also offers the Nitrogen Cylinder/Mechanical Spring Combination System for the slide return function of all Aerial and Diemount cam units.**

**The possible benefit of using the Combination System is twofold:**

1. The force developed in the slide return system is low when the accelerator function is active (because only the mechanical spring is operative at that point), thus, wearing of the accelerator components is greatly reduced.
2. The total developed slide return force at the cam's shut height position is greater with the Combination System than it is with the Nitrogen-only option. The result is more on-board capability for part stripping.

### PART NUMBER KEY

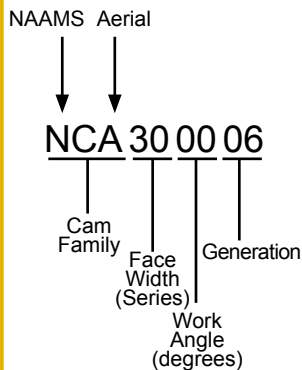

### OPTIONAL SHOCK ABSORBERS

Optional shock absorbers are available and should be used in the absence of an accelerator system on low-angle cams (i.e., less than 25°) to ensure a gentle return of the slide to its home position.



Shock Absorber

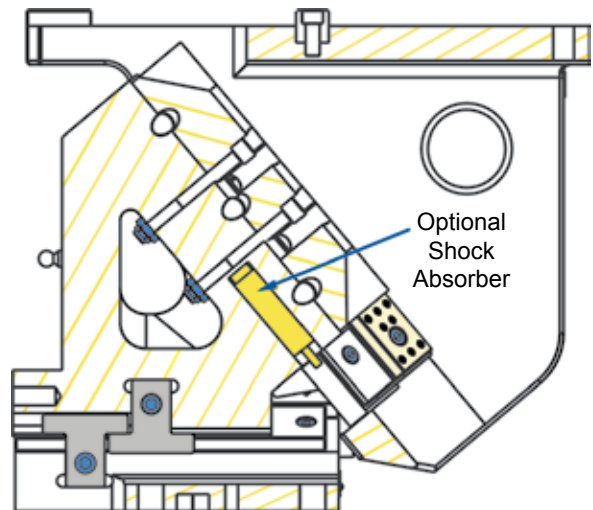

Optional Shock Absorber

## SLIMCAM™ NLD SERIES CAM

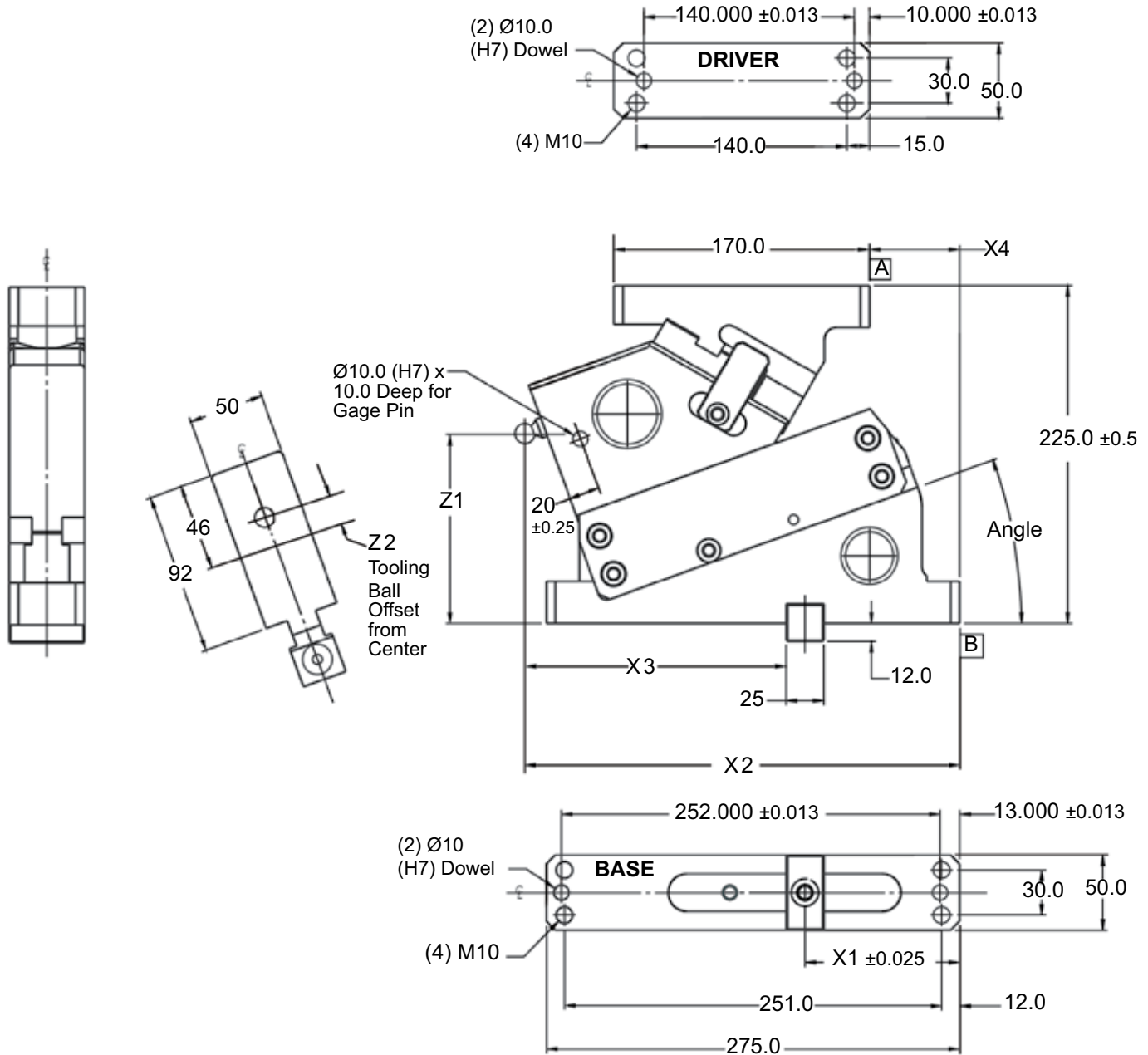

## SLIMCAM™ NLD SERIES CAM

### DIEMOUNT CAM DIMENSIONS AND WEIGHTS

CAM PART NUMBER	WEIGHT		CAM ANGLE	X1	X2	X3	X4	Z1	Z2
	KG	LBS.		Class of Key		Ref.	Base to Driver Datum	NAAMS A	Ref.
NLD050006_	20	44	0°	93.4	262.0	156.1	28.0	160.0	11.0
NLD050506_	19	42	5°	93.7	275.0	158.9	35.0	150.0	9.8
NLD051006_	20	43	10°	92.9	269.2	163.8	37.0	140.0	11.0
NLD051506_	18	40	15°	107.6	284.6	164.5	53.0	135.0	12.2
NLD052006_	18	40	20°	102.9	289.1	173.7	60.0	130.0	14.3
NLD052506_	18	40	25°	109.4	289.3	167.4	75.0	115.0	6.7
NLD053006_	18	40	30°	107.0	286.1	166.6	81.0	105.0	2.7

↑ Specify spring type

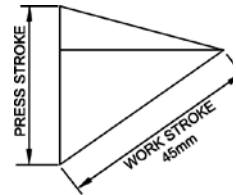

**CAM DIAGRAM**

ANGLE	PRESS STROKE	WORK STROKE
0	53.6	45
5	48.8	45
10	45.0	45
15	42.1	45
20	39.8	45
25	38.0	45
30	36.7	45

**SLIMCAM™ NLD SERIES CAM  
COMPONENT PARTS**

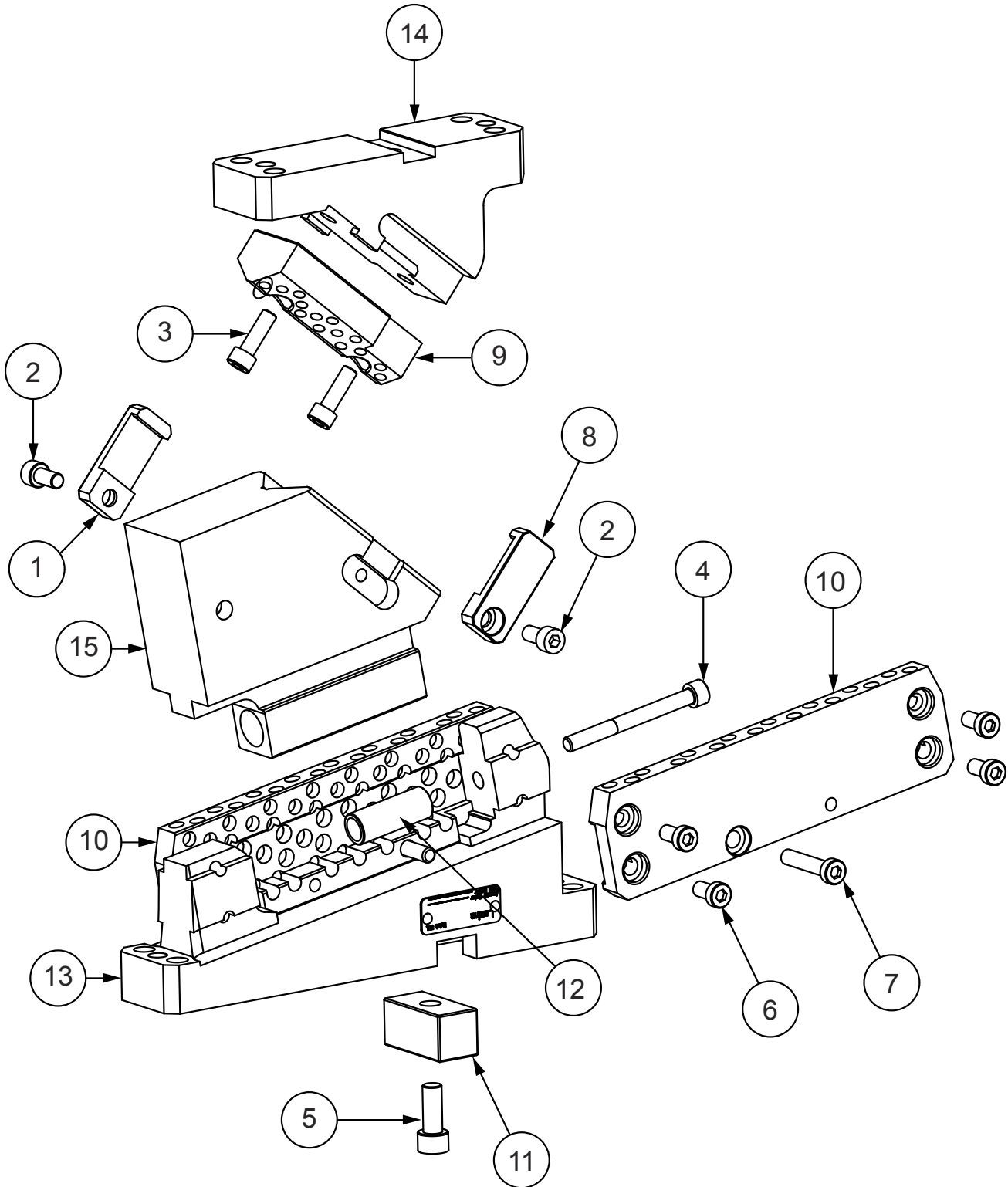

## SLIMCAM™ NLD SERIES CAM

SLIMCAM™ NDA SERIES DIEMOUNT CAMS REPLACEMENT PARTS			
ITEM NUMBER	DESCRIPTION	ITEM NUMBER	DESCRIPTION
1	RH Positive Return	9	V-Block NLA/NLD 50 Cam
2	M8 x 1.25 x 16 SHCS	10	NLA Keeper Plate
3	M8 x 1.25 x 25 SHCS	11	25 x 25 x 50mm NAAMS Key
4	M8 x 1.25 x 80 SHCS	12	Lockout Spacer
5	M10 x 1.5 x 25 SHCS	13	Body
6	M8 x 1.25 x 16 LHCS	14	Driver
7	M8 x 1.25 x 16 LHCS	15	Slide
8	LH Positive Return		

CAM SPECIFICATIONS – SLIMCAM™		
Tooling Allowance		
Size & Weight Parameters	Protrusion 125mm	Weight 4kg
Rated Capacity - kN		
Cycles	300,000	1,000,000
Load Rating	61kN	53kN

RETURN SPRING KIT OPTIONS – NITROGEN ONLY FOR SLIMCAM™					
VENDOR	CAM # SUFFIX	SPRING KIT PART #	QTY	INITIAL LOAD (N)	FINAL LOAD (N)
Dadco	D	<b>C.090.050</b>	1	890	1109
Dadco Ultra	U	<b>CLNA0050-0048</b>	1	1700	2550
Kaller	K	<b>R19-050Y</b>	1	900	1161
Kaller Powerline	P	<b>CLNA0050-0019</b>	1	1700	2550

## DIEMOUNT 50 SERIES CAM

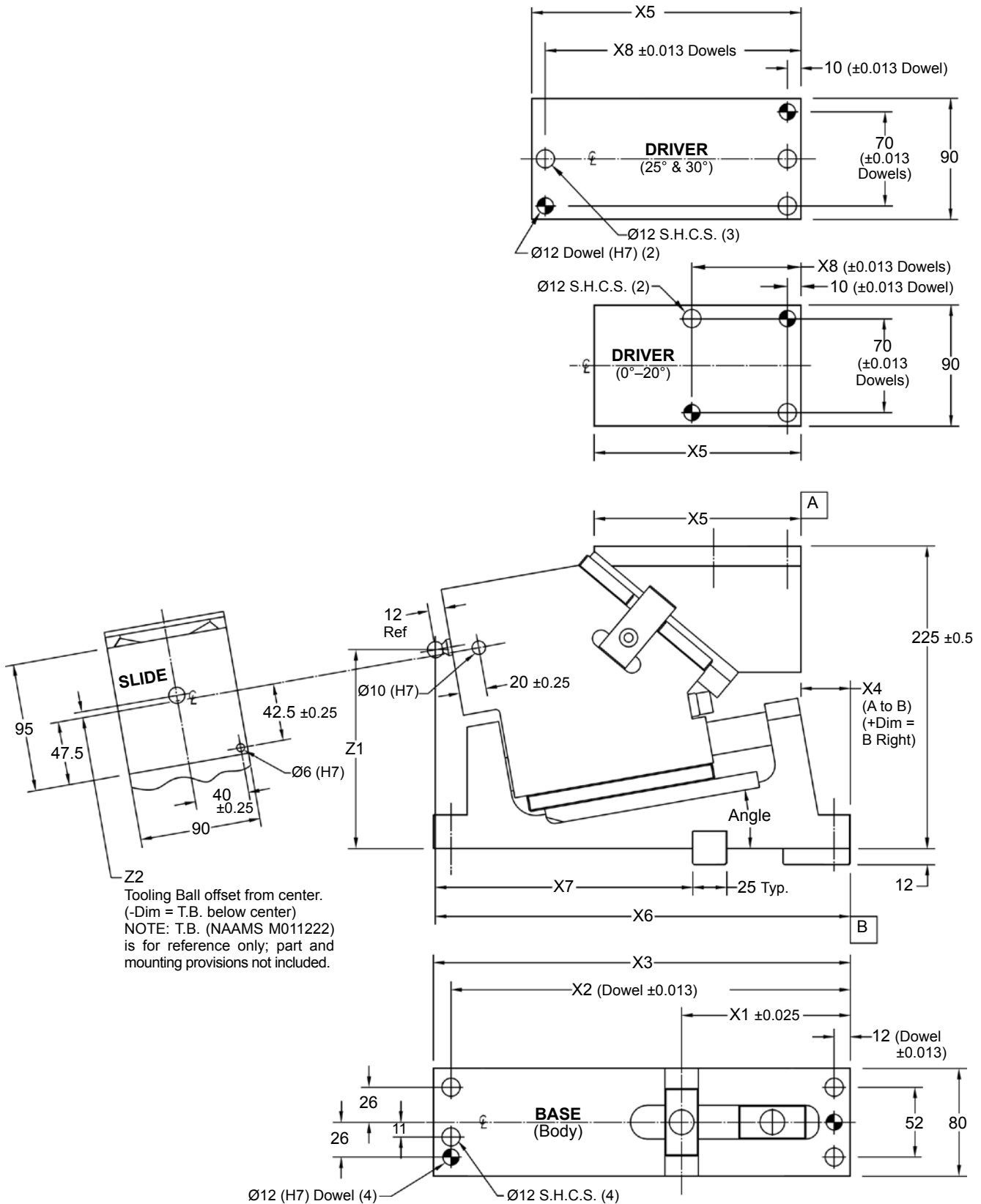

AUTOMOTIVE METRIC  
**NAAMS** STANDARD



## DIEMOUNT 50 SERIES CAM

### DIEMOUNT CAM DIMENSIONS AND WEIGHTS

CAM PART NUMBER	WEIGHT		CAM ANGLE	X1	X2	X3	X4	X5	X6	X7	X8	Z1	Z2
	KG	LBS.		Class of Key		Ref.	Base to Driver Datum	Ref.				NAAMS A	Ref.
NCD050006_	36	79	0°	100.50	288	300	21.9	130.9	283.0	170.0	50.0	160.0	-6.6
NCD050506_	37	81	5°	109.90	298	310	39.4	141.9	302.4	180.0	50.0	150.0	-1.8
NCD051006_	37	81	10°	104.64	297	310	36.8	153.5	307.1	190.0	65.0	140.0	-3.9
NCD051506_	38	83	15°	110.53	307	320	54.3	160.0	323.0	200.0	85.0	135.0	2.3
NCD052006_	37	81	20°	96.74	297	310	55.0	160.0	319.2	210.0	81.0	130.0	4.6
NCD052506_	37	81	25°	100.91	297	310	63.3	200.0	323.4	210.0	190.0	115.0	2.2
NCD053006_	36	79	30°	104.89	288	300	63.7	200.0	317.4	200.0	190.0	105.0	-2.0

↑ Specify spring type

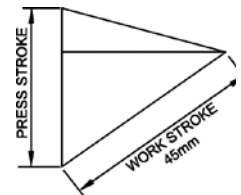

**CAM DIAGRAM**

ANGLE	PRESS STROKE	WORK STROKE
0	53.6	45
5	48.8	45
10	45.0	45
15	42.1	45
20	39.8	45
25	38.0	45
30	36.7	45

Take a look at our extensive line of LamCam™ products:

- Aerial NAAMS Cams
- Diemount NAAMS Cams
- Aerial Modular Cams
- Diemount Modular Cams
- 50mm SlimCams
- RollerCams
- Bump Cams

*This apparatus is covered by U.S. Patent No. 5,885,521, European Patent No. 1097010 in Austria, Belgium, Germany, Spain, France, united Kingdom, Ireland and Italy; other patents pending.*

## DIEMOUNT 50 SERIES CAM COMPONENT PARTS

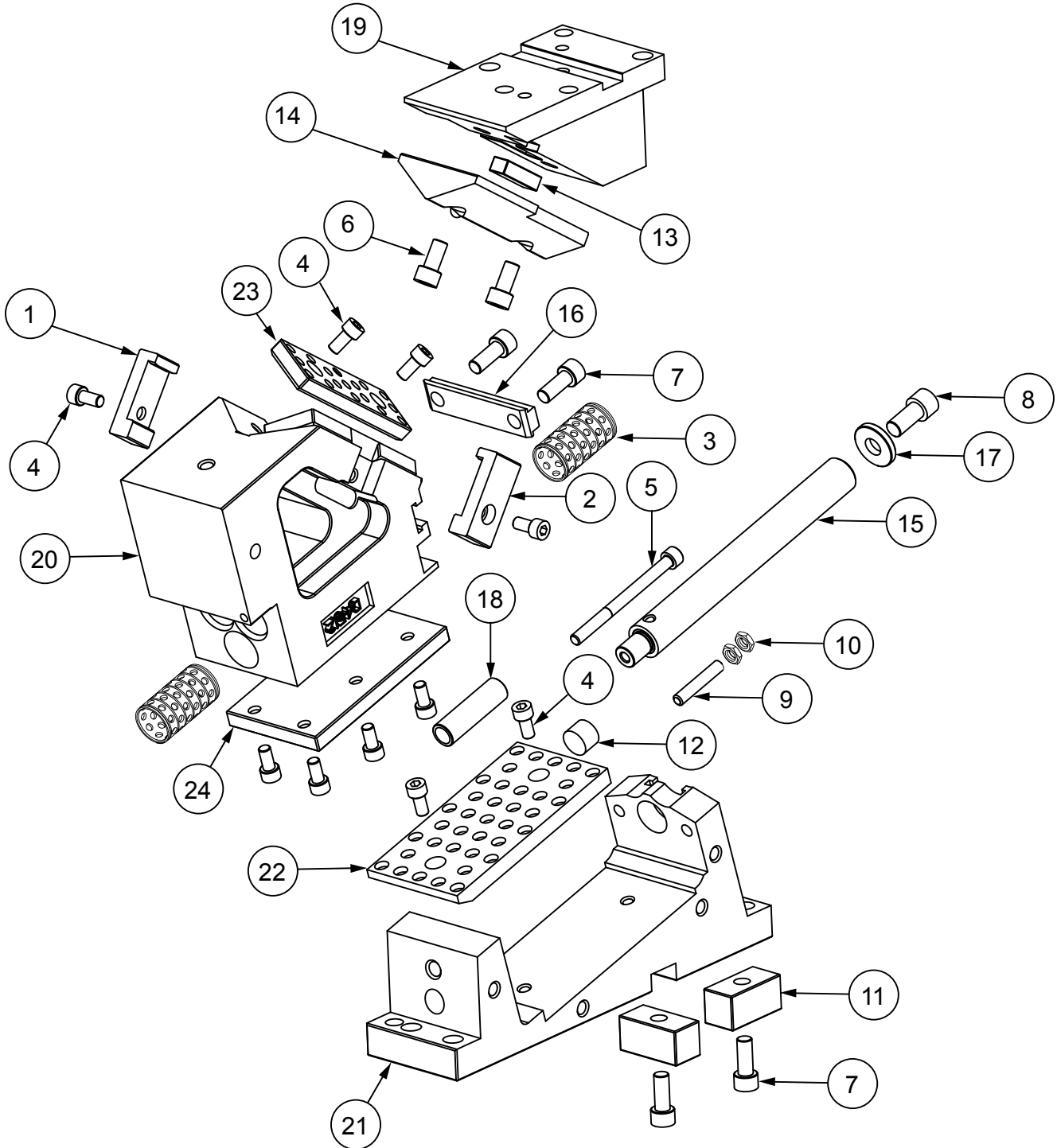

Refer to 50 Series Specification Table for Return Spring Options. See page 3 for more information.

## DIEMOUNT 50 SERIES CAM

50 SERIES DIEMOUNT CAMS REPLACEMENT PARTS			
ITEM NUMBER	DESCRIPTION	ITEM NUMBER	DESCRIPTION
1	RH Positive Return	13	Key 10 x 12.7 x 40mm
2	LH Positive Return	14	V-Block
3	Bronze Self Lube Bushing	15	Guide Pin
4	M8 x 1.25 x 16 SHCS	16	Spring Bracket
5	M8 x 1.25 x 100 SHCS	17	Disk Plate
6	M10 x 1.5 x 20 SHCS	18	Lockout Spacer x 59mm LG
7	M10 x 1.5 x 25 SHCS	19	Driver
8	M12 x 1.75 x 25 SHCS	20	Slide
9	M8 x 45mm LG Soc Set Screw	21	Body
10	M8 X 1.25 Jam Nut	22	12 x 80 x 160mm BRZ S/L WP
11	25 x 25 x 50mm NAAMS Key	23	12 x 40 x 122.5mm BRZ S/L WP
12	Bumper	24	12 x 80 x 145mm HD Steel WP

CAM SPECIFICATIONS – 50 Series Cam		
Tooling Allowance		
Size & Weight Parameters	Protrusion	Weight
	125mm	7kg
Rated Capacity - kN		
Cycles	300,000	1,000,000
Load Rating	174kN	152kN

RETURN SPRING KIT OPTIONS					
VENDOR	CAM # SUFFIX	SPRING KIT PART #	QTY	INITIAL LOAD (N)	FINAL LOAD (N)
Coil Spring	C	<b>SKC050001</b>	2	167	635
Dadco	D	<b>SKC050014</b>	2	4000	4933
Dadco Ultra	U	<b>CLNA0050-0050</b>	2	6400	8773
Dadco Coil/Nitrogen	CD	<b>SKC050012</b>	2	219	751
Kaller	K	<b>SKC050005</b>	2	4000	5272
Kaller Powerline	P	<b>CLNA0050-0036</b>	2	6400	8926
Kaller Coil/Nitrogen	CK	<b>SKC050002</b>	2	219	751

## DIEMOUNT 75 SERIES CAM

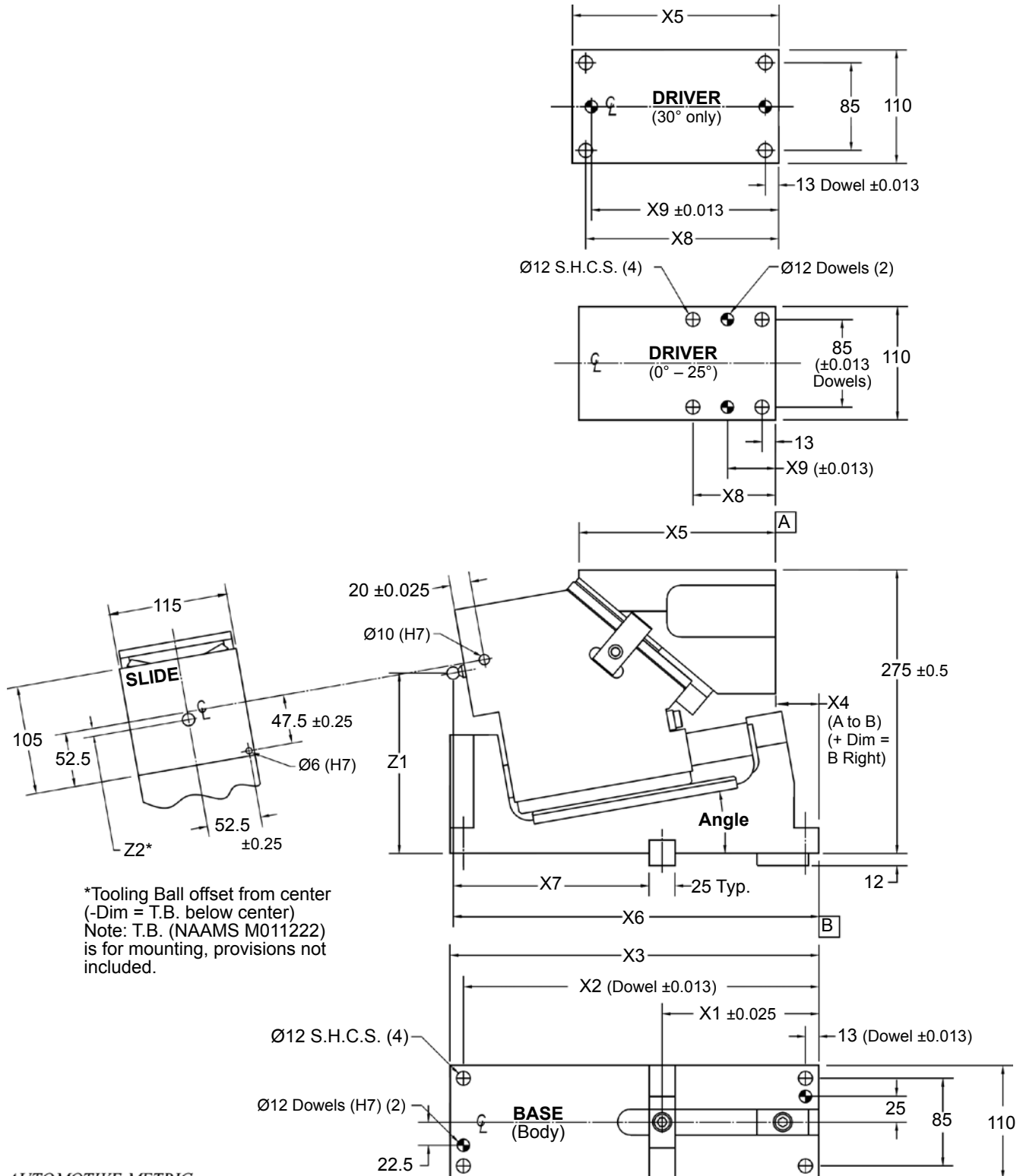

AUTOMOTIVE METRIC  
**NAAMS** STANDARD

## DIEMOUNT 75 SERIES CAM

### DIEMOUNT CAM DIMENSIONS AND WEIGHTS

CAM PART NUMBER	WEIGHT		CAM ANGLE	X1	X2	X3	X4	X5	X6	X7	X8	X9	Z1	Z2
	KG	LBS.		Class of Key		Ref.	Base to Driver Datum	Ref.					NAAMS A	Ref.
NCD070006_	49	108	0°	149.50	352.0	365.0	47.6	150	332.0	170.0	70.0	41.5	200.0	4
NCD070506_	51	112	5°	149.60	352.0	365.0	30.4	180	342.1	180.0	75.0	44.0	190.0	1
NCD071006_	51	112	10°	151.96	344.5	357.5	42.1	190	354.5	190.0	80.0	46.5	175.0	-8
NCD071506_	52	114	15°	147.50	332.0	345.0	45.6	200	360.0	200.0	105.0	80.0	165.0	-11
NCD072006_	51	112	20°	144.47	347.0	360.0	60.4	200	367.0	210.0	110.0	85.0	155.0	-13
NCD072506_	52	114	25°	137.48	333.0	346.0	68.0	200	365.0	215.0	115.0	94.0	145.0	-15
NCD073006_	51	112	30°	138.96	334.5	347.5	77.0	245	371.5	220.0	232.0	229.0	135.0	-7

↑ Specify spring type

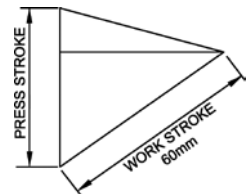

**CAM DIAGRAM**

ANGLE	PRESS STROKE	WORK STROKE
0	71.5	60
5	65.0	60
10	60.0	60
15	56.1	60
20	53.1	60
25	50.7	60
30	48.9	60

## DIEMOUNT 75 SERIES CAM COMPONENT PARTS

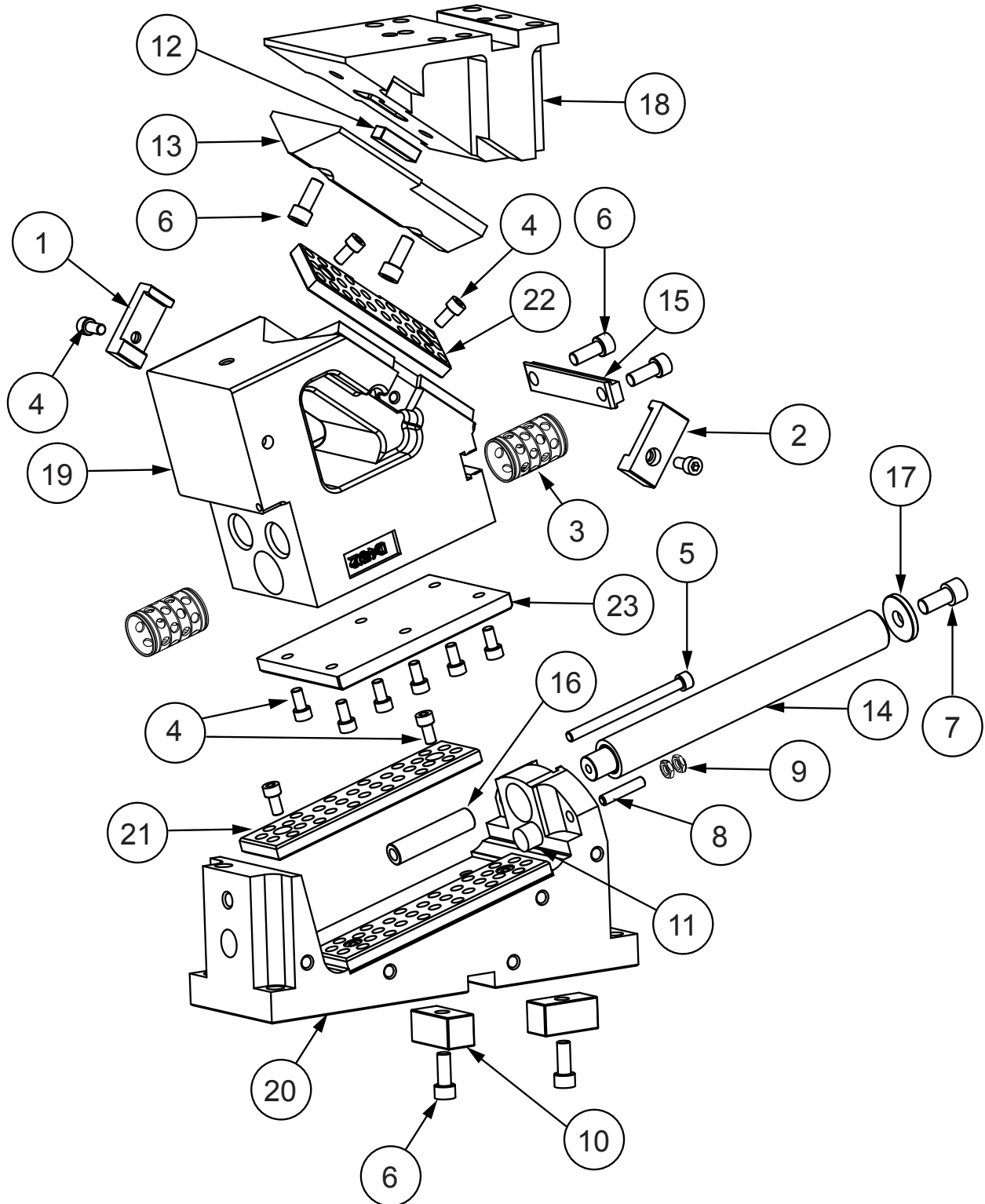

Refer to 75 Series Specifications Table for Return Spring Options. See page 3 for more information.

## DIEMOUNT 75 SERIES CAM

75 SERIES DIEMOUNT CAMS REPLACEMENT PARTS			
ITEM NUMBER	DESCRIPTION	ITEM NUMBER	DESCRIPTION
1	RH Positive Return	13	V-Driver
2	LH Positive Return	14	Guide Pin
3	Bronze Bushing	15	Spring Bracket
4	M8 x 1.25 x 16 SHCS	16	Lockout Spacer
5	M8 x 1.25 x 110 SHCS	17	Disk Plate
6	M10 x 1.5 x 25 SHCS	18	Driver
7	M12 x 1.75 x 25 SHCS	19	Slide
8	M8 x 40mm LG Soc Set Screw	20	Body
9	M8 X 1.25 Jam Nut	21	12 x 50 x 200mm BRZ S/L WP
10	25 x 25 x 50mm NAAMS Key	22	12 x 50 x 150mm BRZ S/L WP
11	Bumper	23	12 x 170 x 110mm HD Steel WP
12	Key 10 x 12.7 x 40mm		

CAM SPECIFICATIONS – 75 Series Cam		
Tooling Allowance		
Size & Weight Parameters	Protrusion	Weight
	140mm	10kg
Rated Capacity - kN		
Cycles	300,000	1,000,000
Load Rating	214kN	187kN

RETURN SPRING KIT OPTIONS					
VENDOR	CAM # SUFFIX	SPRING KIT PART #	QTY	INITIAL LOAD (N)	FINAL LOAD (N)
Coil Spring	C	<b>SKC070001</b>	2	372	2620
Dadco	D	<b>SKC070014</b>	2	4000	4933
Dadco Ultra	U	<b>CLNA0075-0023</b>	2	6400	9106
Dadco Coil/Nitrogen	CD	<b>SKC070012</b>	2	412	2824
Kaller	K	<b>SKC070015</b>	2	4000	5381
Kaller Powerline	P	<b>CLNA0075-0014</b>	2	6400	9106
Kaller Coil/Nitrogen	CK	<b>SKC070002</b>	2	412	2824

## DIEMOUNT 125 – 150 SERIES CAM

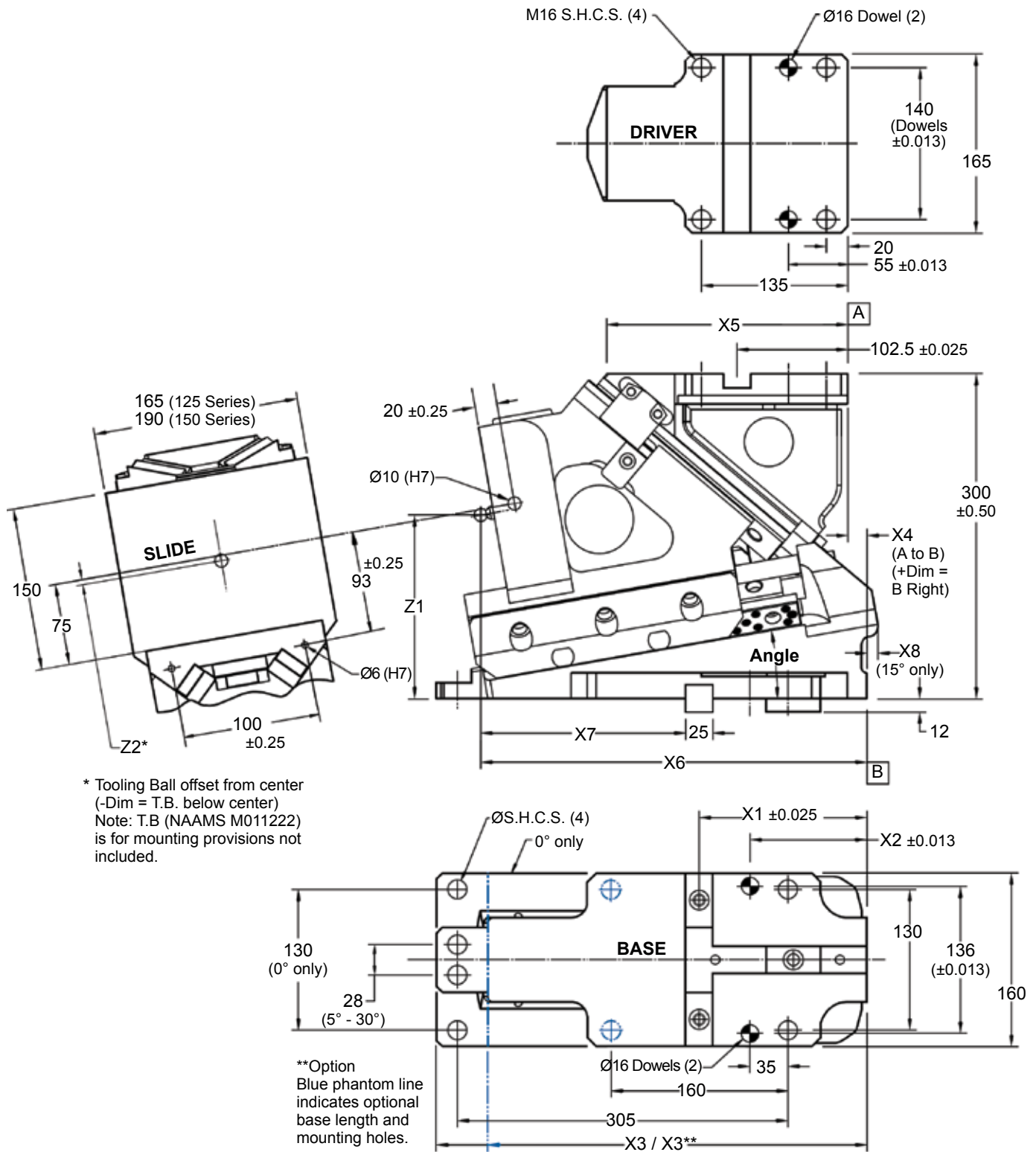

AUTOMOTIVE METRIC  
 NAAMS STANDARD



## DIEMOUNT 125 – 150 SERIES CAM

### DIEMOUNT CAM DIMENSIONS AND WEIGHTS

CAM PART NUMBER	WEIGHT		CAM ANGLE	X1	X2	X3	X3*	X4	X5	X6	X7	X8	Z1	Z2
	KG	LBS.		Class of Key		Ref.		Base to Driver Datum	Ref.				NAAMS A	Ref.
NCD120006_	83	183	0°	154.50	108	398	360	-22.0	223	337.0	170	-	200.0	3.0
NCD120506_	84	185	5°	157.46	108	398	365	-5.6	228	350.0	180	-	190.0	2.6
NCD121006_	86	189	10°	154.83	108	398	365	17.7	223	357.3	190	-	175.0	0.4
NCD121506_	85	187	15°	143.08	100	390	357	28.2	229	355.6	200	8	165.0	0
NCD122006_	86	189	20°	150.89	103	393	360	32.3	254	373.4	210	-	155.0	-1.6
NCD122506_	80	176	25°	115.07	65	355	320	35.3	226	337.6	210	34	145.0	-0.2
NCD123006_	83	183	30°	127.15	65	355	320	63.5	222	349.7	210	25	135.0	-2.9
NCD150006_	86	189	0°	154.50	108	398	360	-22.0	223	337.0	170	-	200.0	3.0
NCD150506_	87	191	5°	157.46	108	398	365	-5.6	228	350.0	180	-	190.0	2.6
NCD151006_	89	196	10°	154.83	108	398	365	17.7	223	357.3	190	-	175.0	0.4
NCD151506_	88	194	15°	143.08	100	390	357	28.2	229	355.6	200	8	165.0	0
NCD152006_	89	196	20°	150.89	103	393	360	32.3	254	373.4	210	-	155.0	-1.6
NCD152506_	83	183	25°	115.07	65	355	320	35.3	226	337.6	210	34	145.0	-0.2
NCD153006_	86	189	30°	127.15	65	355	320	63.5	222	349.7	210	25	135.0	-2.9

↑ Specify spring type

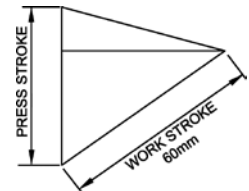

**CAM DIAGRAM**

ANGLE	PRESS STROKE	WORK STROKE
0	71.5	60
5	65.0	60
10	60.0	60
15	56.1	60
20	53.1	60
25	50.7	60
30	48.9	60

## DIEMOUNT 125 – 150 SERIES CAM COMPONENT PARTS

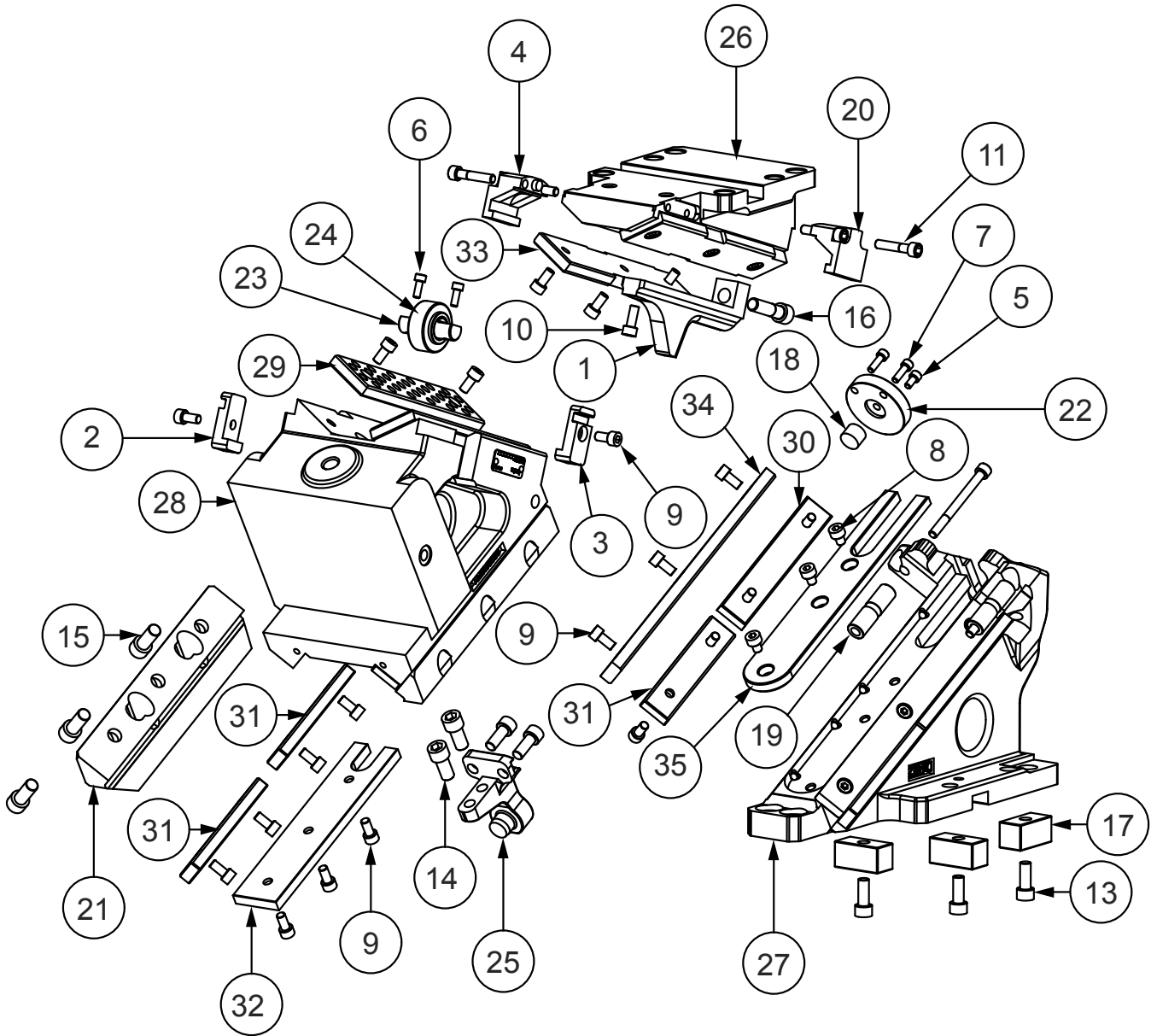

Refer to 125 – 150 Series Specifications Table for Return Spring Options. See page 3 for more information.

SHOCK ABSORBERS-OPTIONAL		
Qty	PART NUMBER	DESCRIPTION
2	MSC100028	Shock Absorber Assemblies

## DIEMOUNT 125 – 150 SERIES CAM

125 – 150 SERIES DIEMOUNT CAMS REPLACEMENT PARTS			
ITEM NUMBER	DESCRIPTION	ITEM NUMBER	DESCRIPTION
1	Accelerator Ramp 25° & 30° only	19	Lockout Spacer
2	RH Positive Return	20	LH Positive Return Bracket
3	LH Positive Return	21	Keeper Plate
4	RH Positive Return Bracket	22	Disk Plate
5	M6 x 1.0 x 12 SHCS	23	Roller Shaft 25° & 30° only
6	M6 x 1.0 x 16 SHCS	24	Roller 25° & 30° only
7	M6 x 1.0 x 20 SHCS	25	Spring Return Bracket
8	M8 x 1.25 x 10 SHCS	26	Driver
9	M8 x 1.25 x 16 SHCS	27	Body
10	M8 x 1.25 x 20 SHCS	28	Slide
11	M8 x 1.25 x 40 SHCS	29	12 x 50 x 200mm BRZ S/L WP
12	M8 x 1.25 x 90 SHCS	30	12 x 30 x 160mm BRZ S/L WP
13	M10 x 1.5 x 25 SHCS	31	12 x 30 x 125mm BRZ S/L WP
14	M12 x 1.75 x 25 SHCS	32	12 x 50 x 225mm BRZ S/L WP
15	M12 x 1.75 x 30 SHCS	33	12 x 48 x 225mm Steel WP
16	M12 x 1.75 x 45 SHCS	34	12 x 30 x 285mm Steel WP
17	25 x 25 x 50mm NAAMS Key	35	12 x 48 x 280mm Steel WP
18	Bumper		

CAM SPECIFICATIONS – 125–150 Series Cam		
Tooling Allowance		
Size & Weight Parameters	Protrusion	Weight
	150mm	20kg
Rated Capacity - kN		
Cycles	300,000	1,000,000
Load Rating	352kN	308kN

RETURN SPRING KIT OPTIONS					
VENDOR	CAM # SUFFIX	SPRING KIT PART #	QTY	INITIAL LOAD (N)	FINAL LOAD (N)
Coil Spring	C	SPG243811CAM	1	265	1559
Dadco	D	90.3.0300.080	1	3020	4010
Dadco Ultra	U	CLNA0125-0025	1	4619	5932
Dadco Coil/Nitrogen	CD	SKC120012	1	432	3540
Kaller	K	TU250-080Y	1	2650	3240
Kaller Powerline	P	CLNA0125-0016	1	4700	6355
Kaller Coil/Nitrogen	CK	SKC120002	1	432	3403

## DIEMOUNT 175 – 200 SERIES CAM

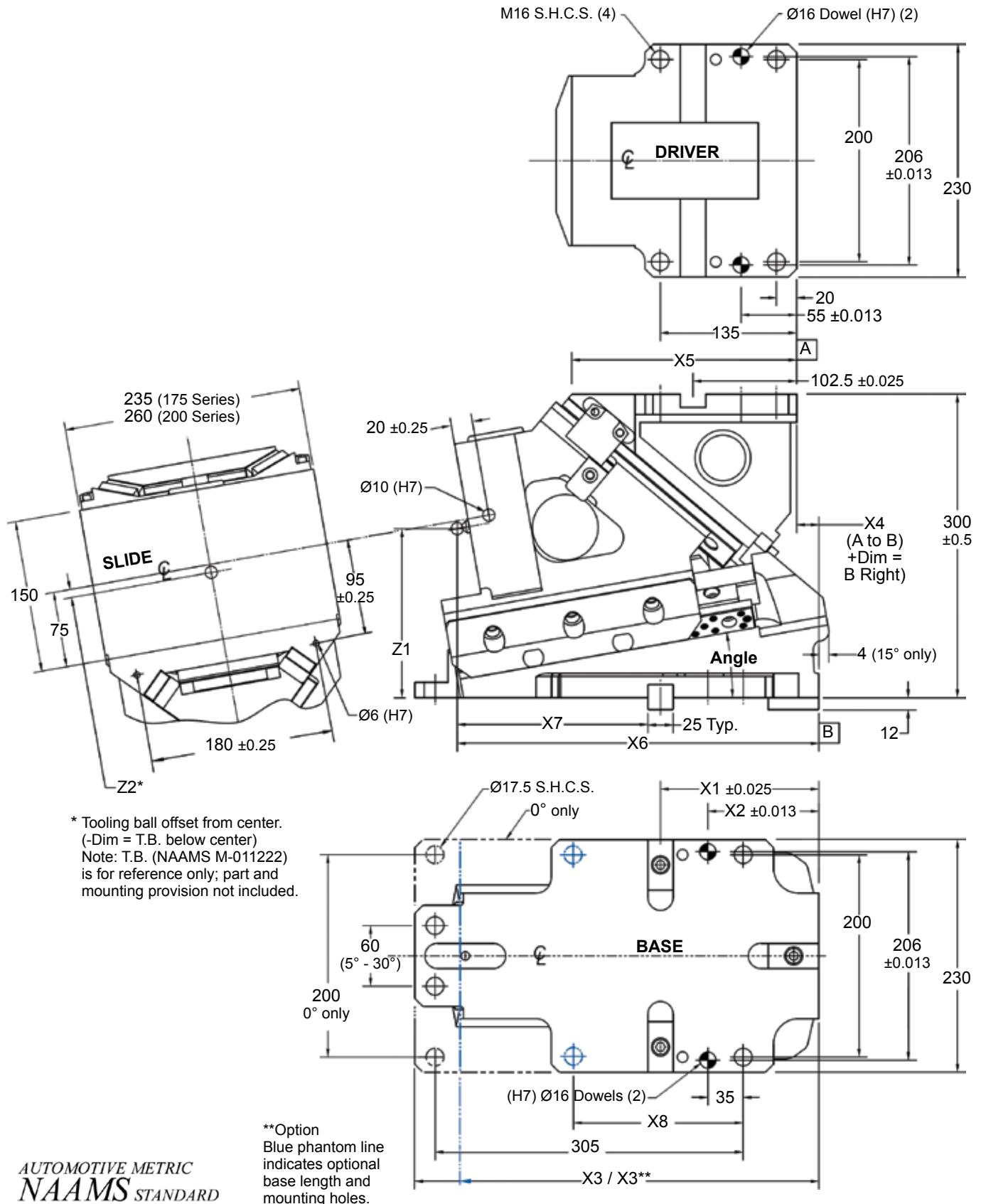

AUTOMOTIVE METRIC  
**NAAMS** STANDARD

## DIEMOUNT 175 – 200 SERIES CAM

### DIEMOUNT CAM DIMENSIONS AND WEIGHTS

CAM PART NUMBER	WEIGHT		CAM ANGLE	X1	X2	X3	X3*	X4	X5	X6	X7	X8	Z1	Z2
	KG	LBS.		Class of Key		Ref.		Base to Driver Datum	Ref.	NAAMS E	NAAMS C	Ref.	NAAMS A	Ref.
NCD170006_	126	277	0°	154.50	108	398	358	-20.0	223	337.0	170.0	222	200	3
NCD170506_	117	257	5°	154.46	115	405	365	-6.4	228	347.0	180.0	170	190	2.7
NCD171006_	115	253	10°	156.83	110	400	365	22.1	223	359.3	190.0	160	175	0.4
NCD171506_	110	242	15°	148.08	100	390	350	32.4	229	360.6	200.0	170	165	0
NCD172006_	111	244	20°	150.89	103	393	360	35.4	254	373.4	210.0	170	155	-1.6
NCD172506_	110	242	25°	115.07	65	355	320	34.2	226	337.6	210.0	170	150	-0.20
NCD173006_	113	249	30°	127.15	65	355	320	63.7	222	349.7	210.0	170	140	-2.90
NCD200006_	128	282	0°	154.50	108	398	358	-20.0	223	337.0	170.0	222	200	3
NCD200506_	119	262	5°	154.46	115	405	365	-6.4	228	347.0	180.0	170	190	2.7
NCD201006_	117	257	10°	156.83	110	400	365	22.1	223	359.3	190.0	160	175	0.4
NCD201506_	112	246	15°	148.08	100	390	350	32.4	229	360.6	200.0	170	165	0
NCD202006_	113	249	20°	150.89	103	393	360	35.4	254	373.4	210.0	170	155	-1.6
NCD202506_	112	246	25°	115.07	65	355	320	34.2	226	337.6	210.0	170	150	-0.20
NCD203006_	115	253	30°	127.15	65	355	320	63.7	222	349.7	210.0	170	140	-2.90

↑ Specify spring type

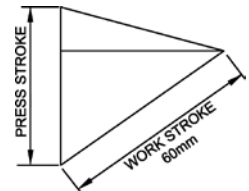

**CAM DIAGRAM**

ANGLE	PRESS STROKE	WORK STROKE
0	71.5	60
5	65.0	60
10	60.0	60
15	56.1	60
20	53.1	60
25	50.7	60
30	48.9	60

## DIEMOUNT 175 – 200 SERIES CAM COMPONENT PARTS

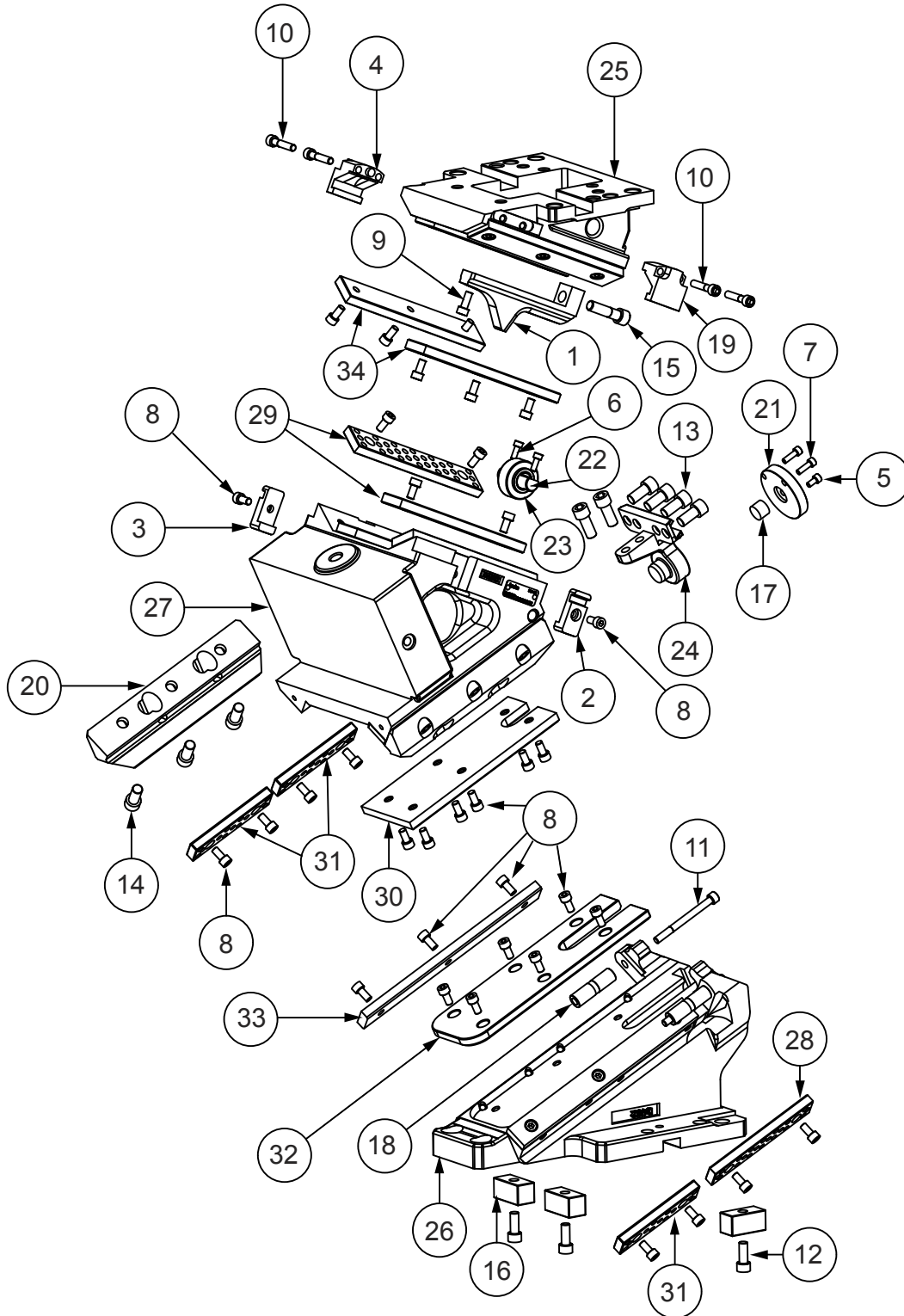

Refer to 175 – 200 Series Specifications Table for Return Spring Options. See page 3 for more information.

SHOCK ABSORBERS-OPTIONAL		
Qty	PART NUMBER	DESCRIPTION
2	MSC100028	Shock Absorber Assemblies

## DIEMOUNT 175 – 200 SERIES CAM

175 – 200 SERIES DIEMOUNT CAMS REPLACEMENT PARTS			
ITEM NUMBER	DESCRIPTION	ITEM NUMBER	DESCRIPTION
1	Accelerator Ramp 25° & 30° only	18	Lockout Spacer
2	RH Positive Return	19	LH Positive Return Bracket
3	LH Positive Return	20	Keeper Plate
4	RH Positive Return Bracket	21	Disk Plate
5	M6 x 1.0 x 12 SHCS	22	Roller Shaft 25° & 30° only
6	M6 x 1.0 x 16 SHCS	23	Roller 25° & 30° only
7	M6 x 1.0 x 20 SHCS	24	Spring Return Bracket
8	M8 x 1.25 x 16 SHCS	25	Driver
9	M8 x 1.25 x 20 SHCS	26	Body
10	M8 x 1.25 x 40 SHCS	27	Slide
11	M8 x 1.25 x 90 SHCS	28	12 x 30 x 160mm BRZ S/L WP
12	M10 x 1.5 x 25 SHCS	29	12 x 38 x 200mm BRZ S/L WP
13	M12 x 1.75 x 25 SHCS	30	12 x 100 x 240mm BRZ S/L WP
14	M12 x 1.75 x 30 SHCS	31	12 x 30 x 125mm BRZ S/L WP
15	M12 x 1.75 x 45 SHCS	32	12 x 100 x 290mm Steel WP
16	25 x 25 x 50mm NAAMS Key	33	12 x 30 x 285mm Steel WP
17	Bumper	34	12 x 38 x 225mm HRD Steel WP

CAM SPECIFICATIONS – 175–200 Series Cam		
Tooling Allowance		
Size & Weight Parameters	Protrusion	Weight
	175mm	32kg
Rated Capacity - kN		
Cycles	300,000	1,000,000
Load Rating	484kN	424kN

RETURN SPRING KIT OPTIONS					
VENDOR	CAM # SUFFIX	SPRING KIT PART #	QTY	INITIAL LOAD (N)	FINAL LOAD (N)
Coil Spring	C	SPG323911CAM	1	402	2442
Dadco	D	SKC170013	1	4710	5810
Dadco Ultra	U	CLNA0175-0030	1	7360	10140
Dadco Coil/Nitrogen	CD	SKC170012	1	503	6903
Kaller	K	SKC170003	1	4700	6056
Kaller Powerline	P	CLNA0175-0020	1	7400	10386
Kaller Coil/Nitrogen	CK	SKC170002	1	503	4540

## DIEMOUNT 250 – 300 SERIES CAM

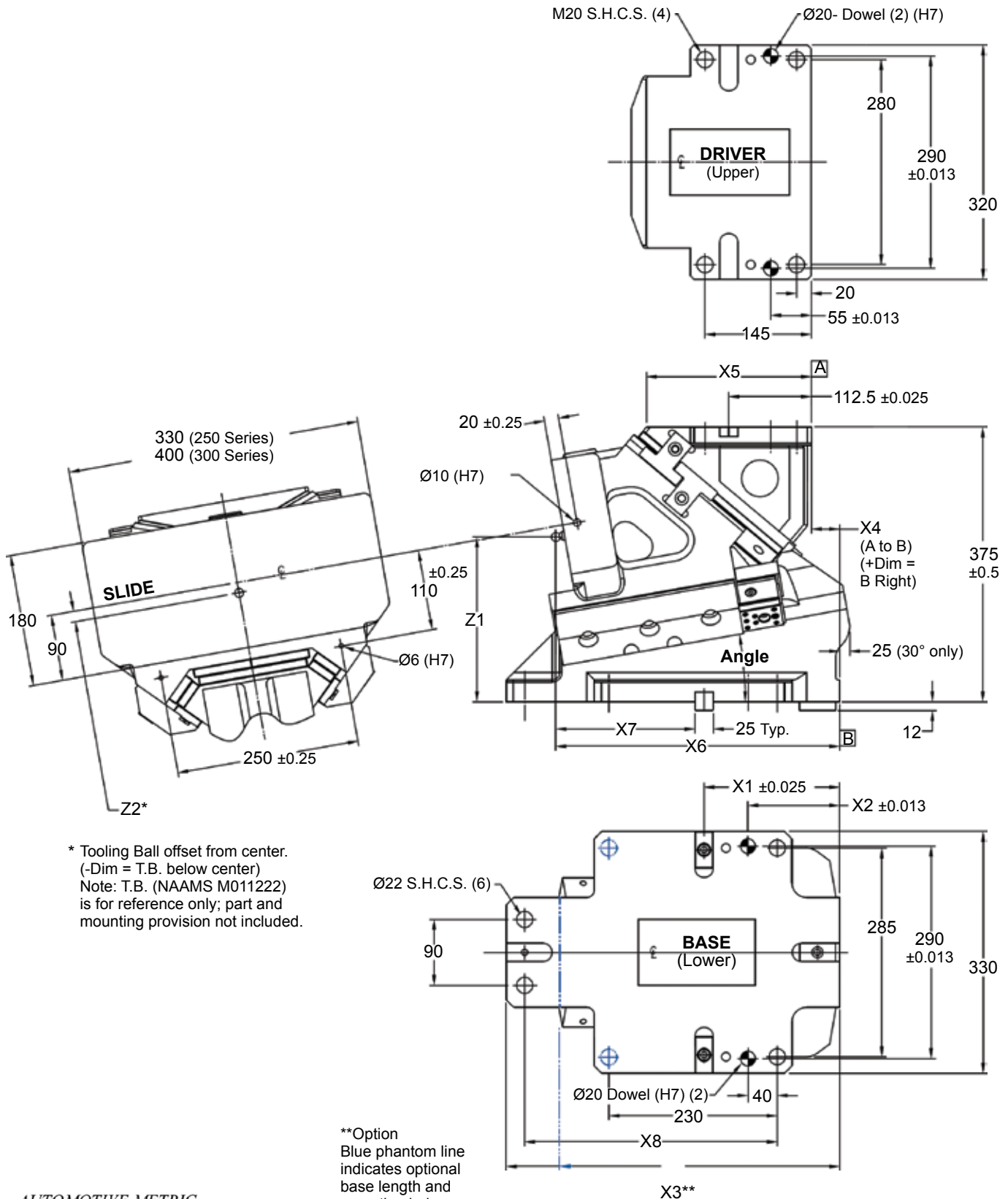

AUTOMOTIVE METRIC  
**NAAMS** STANDARD



## DIEMOUNT 250 – 300 SERIES CAM

### DIEMOUNT CAM DIMENSIONS AND WEIGHTS

CAM PART NUMBER	WEIGHT		CAM ANGLE	X1	X2	X3	X3*	X4	X5	X6	X7	X8	X9	Z1	Z2
	KG	LBS.		Class of Key		Ref.		Base to Driver Datum	Ref.	NAAMS E	NAAMS C	Ref.		NAAMS A	Ref.
NCD250006_	214	472	0°	181.50	135	455	380	-3.7	220.0	364.0	170	335	260	5	15
NCD250506_	197	433	5°	183.98	126	460	390	3.9	225.0	376.5	180	349	235	-1	9
NCD251006_	195	429	10°	184.93	125	455	385	38.7	225.0	387.4	190	345	225	-14	-4
NCD251506_	193	425	15°	191.21	125	479	395	61.9	225.0	403.7	200	370	210	-7	3
NCD252006_	194	427	20°	190.45	120	474	395	73.2	242.5	412.9	210	370	195	-18	-8
NCD252506_	193	425	25°	197.45	120	474	400	97.3	250.0	429.9	220	370	190	-15	N/A
NCD253006_	194	427	30°	154.87	60	414	349	68.7	248.0	387.3	220	370	185	-13	N/A
NCD300006_	222	488	0°	181.50	135	455	380	-3.7	220.0	364.0	170	335	260	5	15
NCD300506_	205	451	5°	183.98	126	460	390	3.9	225.0	376.5	180	349	235	-1	9
NCD301006_	203	447	10°	184.93	125	455	385	38.7	225.0	387.4	190	345	225	-14	-4
NCD301506_	201	442	15°	191.21	125	479	395	61.9	225.0	403.7	200	370	210	-7	3
NCD302006_	202	444	20°	190.45	120	474	395	73.2	242.5	412.9	210	370	195	-18	-8
NCD302506_	201	442	25°	197.45	120	474	400	97.3	250.0	429.9	220	370	190	-15	N/A
NCD303006_	202	444	30°	154.87	60	414	349	68.7	248.0	387.3	220	370	185	-13	N/A

↑ Specify spring type

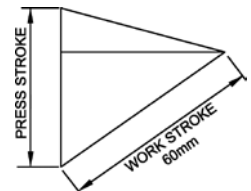

**CAM DIAGRAM**

ANGLE	PRESS STROKE	WORK STROKE
0	71.5	60
5	65.0	60
10	60.0	60
15	56.1	60
20	53.1	60
25	50.7	60
30	48.9	60

## DIEMOUNT 250 – 300 SERIES CAM COMPONENT PARTS

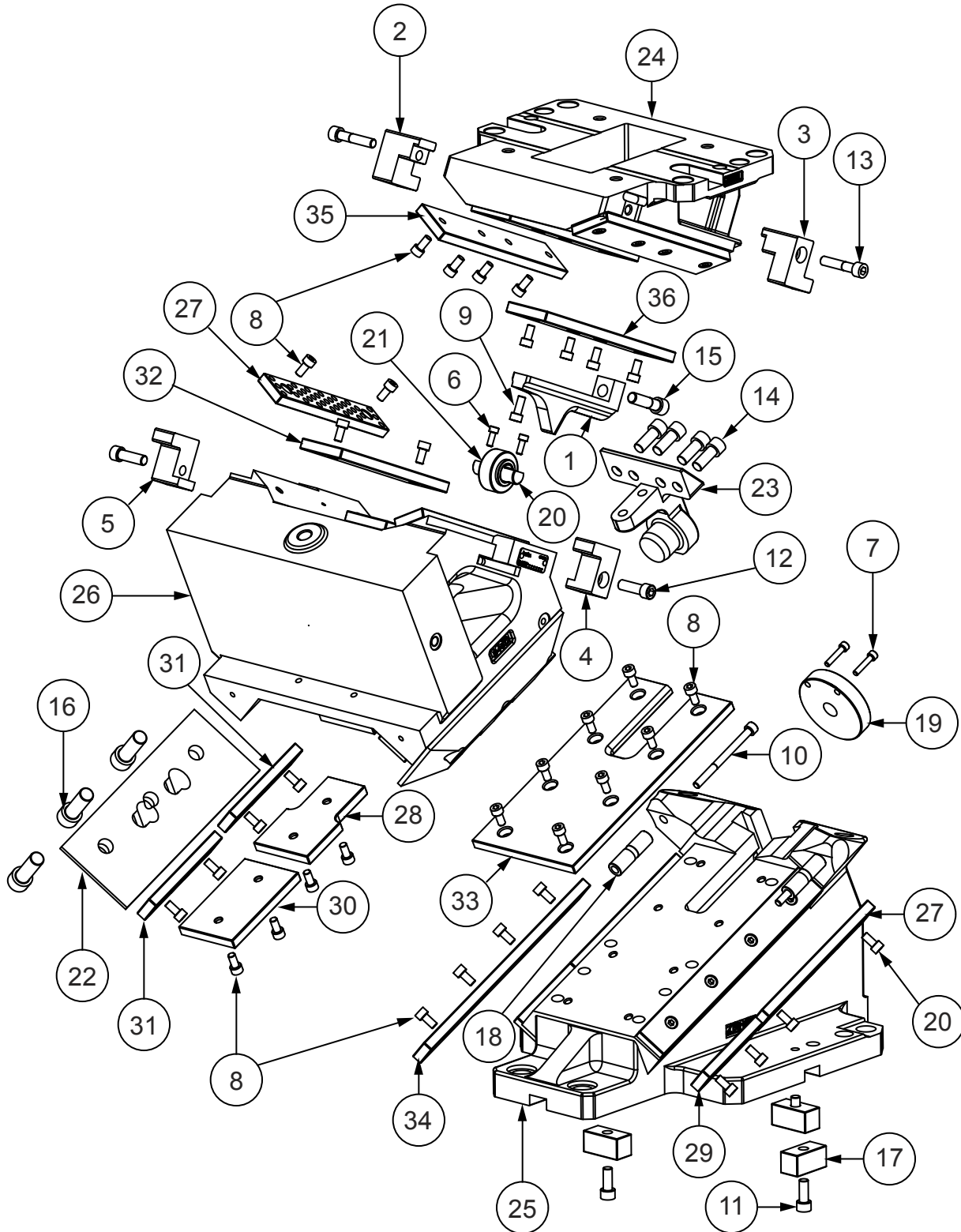

Refer to 250–300 Series Specification Table for Return Spring Options. See page 3 for more information.

SHOCK ABSORBERS—OPTIONAL		
Qty	PART NUMBER	DESCRIPTION
2	MSC100028	Shock Absorber Assemblies

## DIEMOUNT 250 – 300 SERIES CAM

250 – 300 SERIES DIEMOUNT CAMS REPLACEMENT PARTS			
ITEM NUMBER	DESCRIPTION	ITEM NUMBER	DESCRIPTION
1	Accelerator Ramp 25° & 30° only	19	Disk Plate
2	RH Driver Return Bracket	20	Roller Shaft 25° & 30° only
3	LH Driver Return Bracket	21	Roller 25° & 30° only
4	LH Positive Return Key Slide	22	Keeper Plate
5	RH Positive Return Key Slide	23	Spring Return Bracket
6	M6 x 1.0 x 16 SHCS	24	Driver
7	M6 x 1.0 x 30 SHCS	25	Body
8	M8 x 1.25 x 16 SHCS	26	Slide
9	M8 x 1.25 x 20 SHCS	27	12 x 40 x 200mm BRZ S/L WP
10	M8 x 1.25 x 100 SHCS	28	12 x 80 x 125mm BRZ S/L (Notch)
11	M10 x 1.5 x 25 SHCS	29	12 x 40 x 100mm BRZ S/L WP
12	M10 x 1.5 x 35 SHCS	30	12 x 80 x 125mm BRZ S/L WP
13	M10 x 1.5 x 50 SHCS	31	12 x 40 x 125mm BRZ S/L WP
14	M12 x 1.75 x 30 SHCS	32	12 x 60 x 200mm BRZ S/L WP
15	M12 x 1.75 x 45 SHCS	33	12 x 150 x 300mm HRD Steel WP
16	M16 x 2.0 x 50 SHCS	34	12 x 38 x 300mm HRD Steel WP
17	25 x 25 x 50mm NAAMS Key	35	12 x 50 x 250mm HRD Steel WP
	Lockout Spacer	36	12 x 58 x 250mm HRD Steel WP

CAM SPECIFICATIONS – 250-300 Series Cam		
Tooling Allowance		
Size & Weight Parameters	Protrusion 200mm	Weight 65kg
Rated Capacity - kN		
Cycles	300,000	1,000,000
Load Rating	651kN	558kN

RETURN SPRING KIT OPTIONS					
VENDOR	CAM # SUFFIX	SPRING KIT PART #	QTY	INITIAL LOAD (N)	FINAL LOAD (N)
Coil Spring	C	SPG404621CAM	1	471	4462
Dadco	D	SKC250013	1	7400	10386
Dadco Ultra	U	CLNA0300-0017	1	9240	13526
Dadco Coil/Nitrogen	CD	SKC250012	1	1108	7139
Kaller	K	SKC250003	1	7400	10386
Kaller Powerline	P	CLNA0250-0009	1	9200	12384
Kaller Coil/Nitrogen	CK	SKC250002	1	1108	7139

## DIEMOUNT CAMS

Thank you for your purchase of a Lamina NAAMS type cam unit. This unit was manufactured with great care and pride as a simple solution to complex cam operations.

The following information will be helpful during installation and testing of the cam unit. Before installation, please read these instructions thoroughly and not all precautions presented. Keep these instructions with the cam unit until installation is complete and then file them for future reference.

## INSTALLATION

**CAUTION:** When installing the cam unit while the die set is mounted in the press, ensure that safety blocks are in place.

1. Verify that the Return Spring Kit is not in the cam and that the Lockout Kits are installed. If the Spring Kit is installed in the cam:
  - a. Remove the disk plate, spring return bracket (behind disk plate) (**CAUTION:** the spring return bracket has spring pre-load force pushing against it) and spring kit.
  - b. Install the lockout kits by placing the lockout spacer between the slide and the ears of the cam base; install the cap screws provided through the ears, lockout spacer and thread into back of slide. This lock-out position of the slide relates to the specified height of the cam assembly.
  - c. Remove the positive return guide from the slide and the accelerator (where applicable) from the driver.
2. Secure the cam unit base/slide assembly onto the lower die shoe using the print dimensions for location (locate within the indicated tolerance  $\pm 0.5\text{mm}$  left/right and back/front).
  - a. Assemble/match upper and lower die shoes to prescribed shut height.
  - b. Fit the cam driver assembly to cam slide by allowing it to nest laterally.
  - c. Do not tighten the driver mounting screws 100% at this point; tighten only after the driver is seated properly with the slide cam assembly. After this, drill and ream for dowels.
3. Position the tooling components onto the slide face and transfer their mounting screw holes. Utilize established die steels or button to determine this location. Drill and tap the slide face for the tooling components. Removing the slide from the cam unit base assembly may allow easier machining. To remove the slide:
  - a. Remove lockout kit.
  - b. Carefully remove the keeper plates by removing three screws from each keeper plate. The slide may be removed from the cam base.
  - c. After machining for tooling components, assemble the slide back into the cam base by reinstalling keeper plates (torque screws properly) and mount the tooling components to the slide face, fastening with mounting screws (do not fully tighten).
4. Position the tooling components into their final location by using the corresponding die steels/buttons and assuring for proper die clearances. When the location has been satisfied, tighten mounting screws to proper torque.
5. Drill and ream the slide face to dowel the tooling components to slide (refer to #4 above. Use the pull dowels is recommended to locate tooling components).
6. Reattach positive return guide to slide and accelerator to the driver. Determine if accelerator mounting surface must be ground or shimmed to allow smooth engagement of upper roller into lower accelerator (where applicable).
7. Thoroughly clean the cam unit; lubricate the wear plates with light to medium oil. Assemble the cam (if disassembled) and install in die set. This initial lubrication is very important to allow for proper break-in of the cam unit assembly.
8. Verify the free movement of all sliding components. When satisfied as to its function, install the return springs into the cam.
9. Torque all mounting screws to their specified torque ratings.

SEATING TORQUE TABLE					
Soc. Hd. Cap Screw Size	TORQUE N.m/in-Lbs	Soc. Hd. Cap Screw Size	TORQUE N.m/in-Lbs	Soc. Hd. Cap Screw Size	TORQUE N.m/in-Lbs
M6	16/140	M12	135/1,200	M6	14.5/130
M8	39/350	M16	330/2,900	M8	35/310
M10	77/680	N/A	N/A	M10	70/620

# DAYTON Lamina™

a MISUMI Group Company



\*Dayton Lamina's line of Danly products is available only to North America.

[www.daytonlamina.com](http://www.daytonlamina.com)