

FRISBI PENDANT LIGHT
PENDANT

SPECIFICATION SHEET
INTERNATIONAL



FRISBI PENDANT LIGHT

PENDANT

SPECIFICATION SHEET
INTERNATIONAL

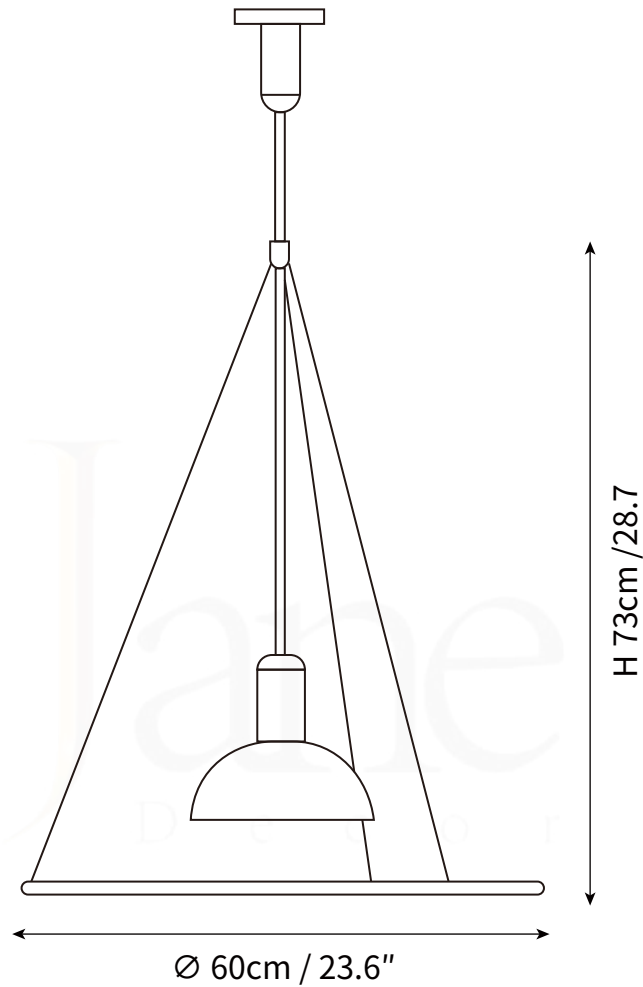

ABOUT

A suspension lamp provides direct, diffused, and reflected light. Opaline polymethylmethacrylate (PMMA) injection-molded diffuser plate suspended by three fine steel cables. Polished, nickel-plated, and zapon-varnished stamped sheet metal reflector painted gloss-white inside. Black painted, injection-molded ABS ceiling fitting and rose.

LEAD TIME

4 - 7 weeks

LIGHT SOURCE

E27 60W LED
2700K warm white
Not dimmable
Lamp included

INSTALLATION

Ceiling mount
Supplied with external driver.

FLEX CORD COLOURS

Black Braided Cable,
Length 150cm / 59".

PRODUCT SIZE

Dia 60cm x H 73cm

FITTING FINISHES

Black, White

SHADE COLOURS

Nickel, Black, Light Grey

CERTIFICATION

CE/CCC/UL/SAA/KC

WARRANTY

3 years

Materials

Metal, Plastic, Steel, PMMA

Voltage

AC 110-240V

WEIGHT

6kg