

PERGOLUX

Et kvalitetsmerke fra Norge

A Quality Brand from Norway

Eine Qualitätsmarke aus Norwegen

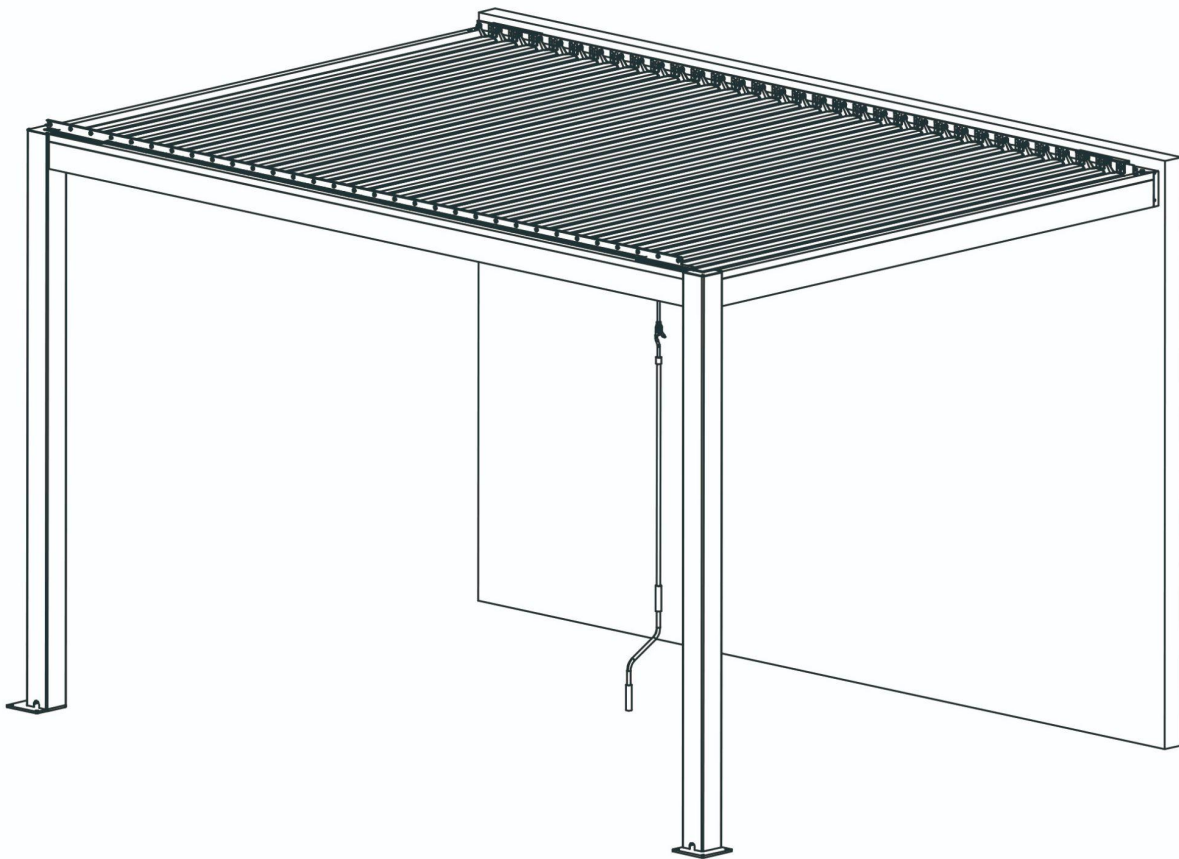

PERGOLUX PERGOLA 3×3/3×4/4×4

VEGGMONTERT / WALL MOUNTED / WANDMONTAGE

Innholdsfortegnelse / Table of Content / Inhaltsverzeichnis

Innholdsliste / List of Items / Artikelliste	3-8
Verktøy / Tools / Werkzeuge	9
Montasje / Instalation / Montage	10-42
- Norsk	10
- English	21
- Deutsch	32
Sikkerhetsinstruksjoner / Security instructions / Sicherheitshinweise	43
Avsluttende ord / Schlussworte / Closing remarks	44-45

Innholdsliste / List of Items / Artikelliste

*Kontroller at du har alle delene før montering. Kontakt oss om noe skulle mangle /
Please check all parts according to the parts list before assembling the pergola /
Bitte den Inhalt der Pakete auf Vollständigkeit überprüfen*

PERGOLUX PERGOLA 3×3

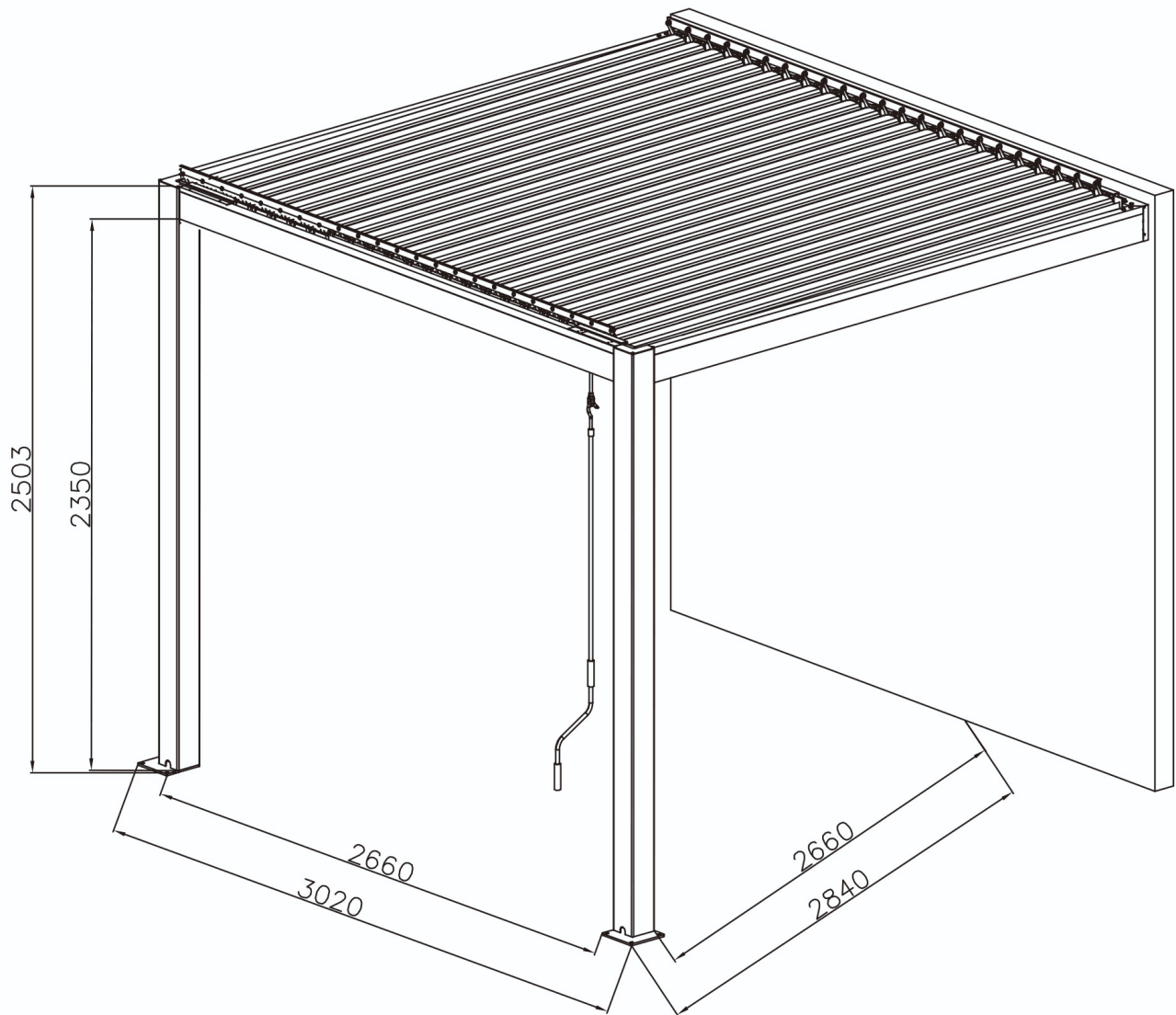

(A1)			x1
(A2)			x1
(B1)			x1
(B2)			x1
(E1)			x1
(E2)			x1
(F1)			x1
(F2)			x1
(D1)			x1
(D2)			x1
(G)			x22
(H)			x1
(J)			x2

(1)		x14	(7)		x64	(13)		x2
(2)		x8	(8)		x1	(14)		x2
(3)		x2	(9)		x4	(15)		x4
(4)		x2	(10)		x4	(16)		x8
(5)		x64	(11)		x4	(17)		x12
(6)		x64	(12)		x2	(18)		x16

- !** Merk: Noen av delene er allerede forhåndsskrudd
- !** Note: Some of the parts may already be pre-assembled
- !** Hinweis: Einige Teile sind bereits vorgeschraubt

PERGOLUX PERGOLA 3x4

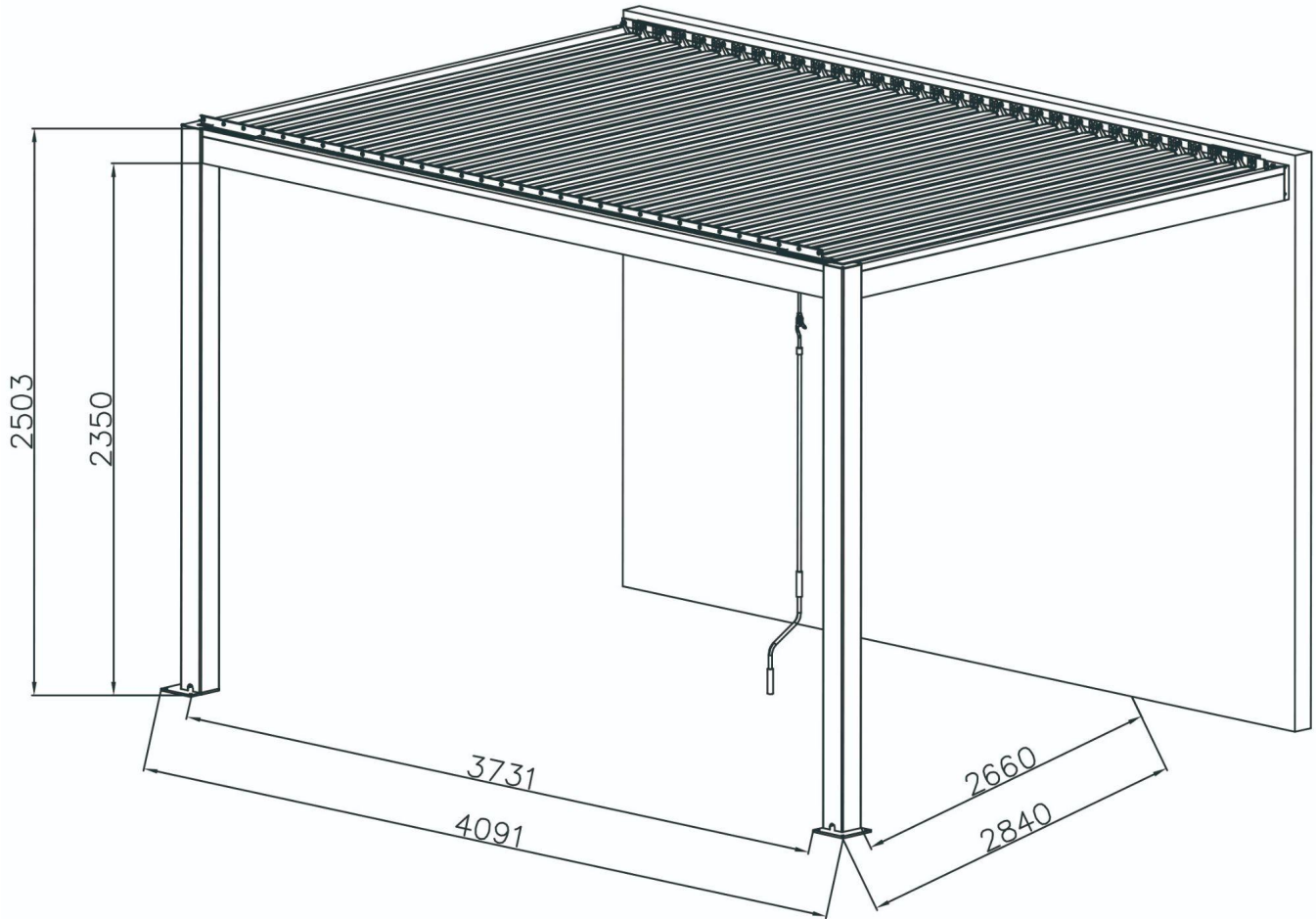

(A1)			x 1					
(A2)			x 1					
(B1)			x 1					
(B2)			x 1					
(E1)			x 1					
(E2)			x 1					
(F1)			x 1					
(F2)			x 1					
(D1)			x 1					
(D2)			x 1					
(G)			x 31					
(H)			x 1					
(J)			x 2					
(1)		x 14	(7)		x 64	(13)		x 2
(2)		x 8	(8)		x 1	(14)		x 2
(3)		x 2	(9)		x 4	(15)		x 4
(4)		x 2	(10)		x 4	(16)		x 8
(5)		x 64	(11)		x 4	(17)		x 12
(6)		x 64	(12)		x 2	(18)		x 16

- ! Merk: Noen av delene er allerede forhåndsskrudd
- ! Note: Some of the parts may already be pre-assembled
- ! Hinweis: Einige Teile sind bereits vorgeschaubt

PERGOLUX PERGOLA 4x4

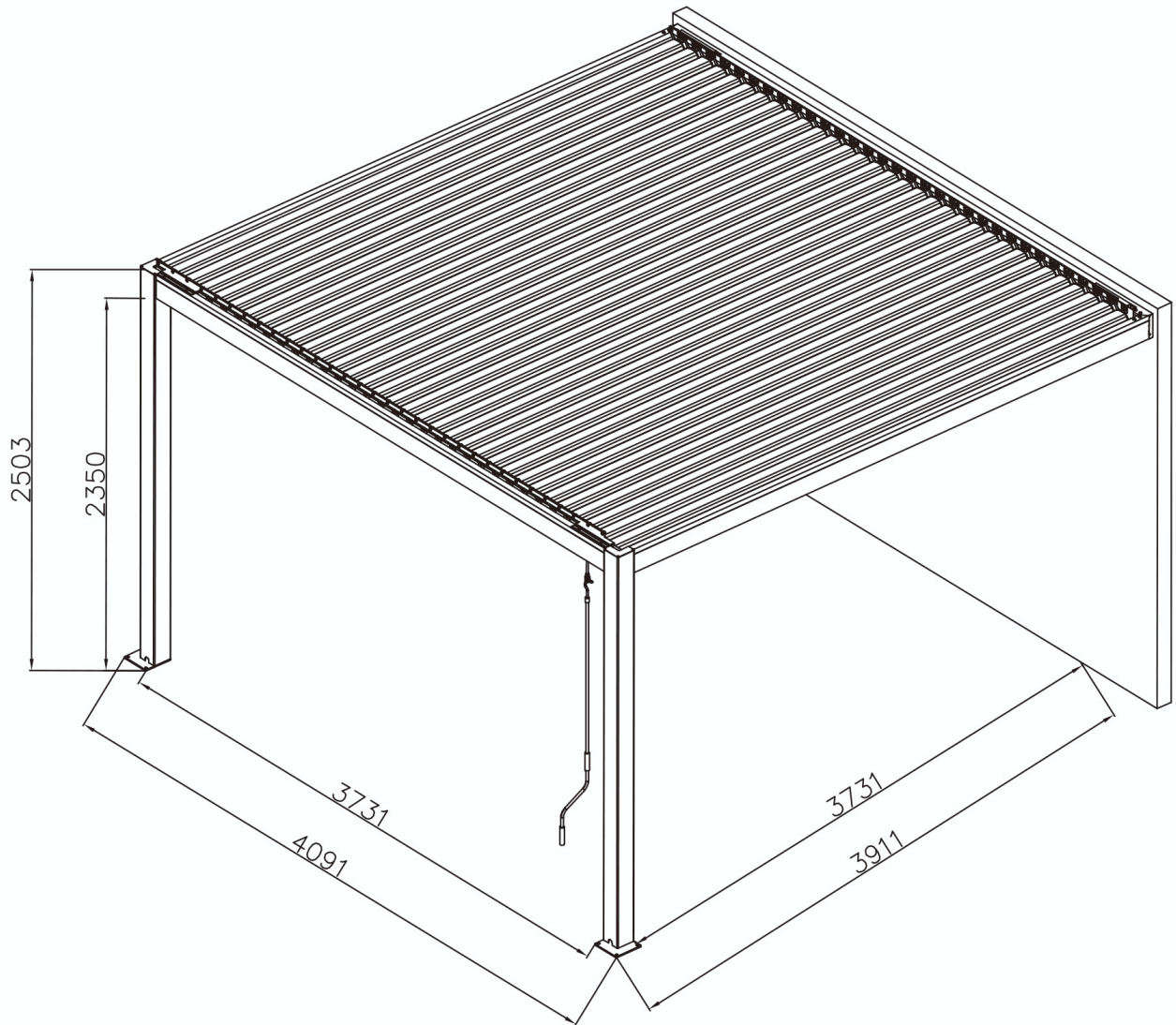

Ⓐ1			x 1
Ⓐ2			x 1
Ⓑ1			x 1
Ⓑ2			x 1
Ⓔ1			x 1
Ⓔ2			x 1
Ⓕ1			x 1
Ⓕ2			x 1
Ⓓ1			x 1
Ⓓ2			x 1
Ⓖ			x 31
Ⓕ			x 1
Ⓙ			x 2
1		x 14	
2		x 8	
3		x 2	
4		x 2	
5		x 64	
6		x 64	
7		x 64	
8		x 1	
9		x 4	
10		x 4	
11		x 4	
12		x 2	
13		x 2	
14		x 2	
15		x 4	
16		x 8	
17		x 12	
18		x 16	

- ! Merk: Noen av delene er allerede forhåndsskrudd
- ! Note: Some of the parts may already be pre-assembled
- ! Hinweis: Einige Teile sind bereits vorgeschaubt

Verktøy / Tools / Werkzeuge

*Det anbefales å være minst 2-3 personer ved montasje av denne pergolaen /
It is recommended to work with a minimum of 2-3 people /
Es wird empfohlen die Montage mit 2-3 Personen durchzuführen*

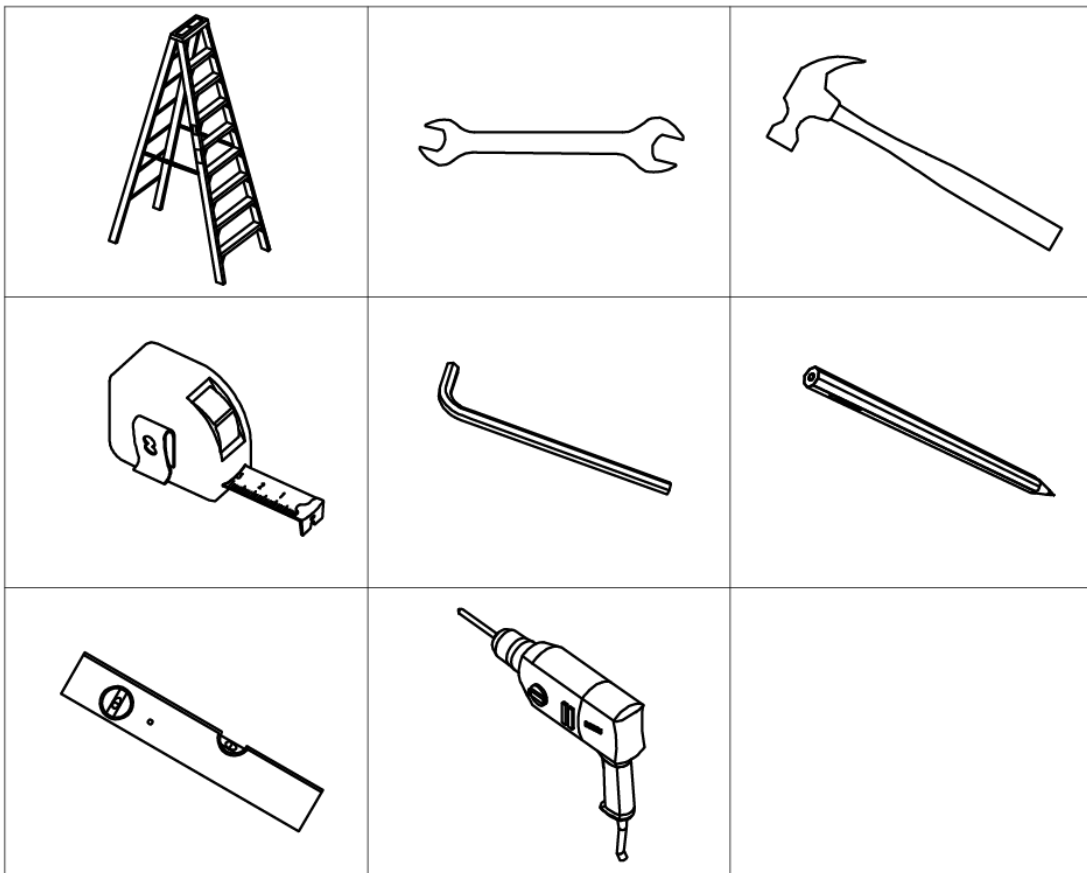
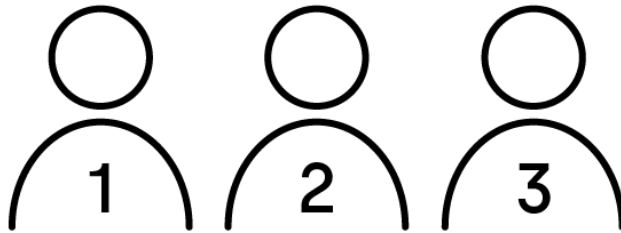

Montering:

Kjære kunde,





Gratulerer med ny pergola og takk for at du handler hos PERGOLUX. Før du starter monteringen er det viktig at du kontrollerer innholdslisten. Sjekk at innholdet i de enkelte pakkene er komplette. Vær oppmerksom på at noen skruer allerede er forhåndsmontert. Hvis emballasjen eller pergolaen har synlige skader, ta et bilde og kontakt oss omgående på kundeservice@pergolux.no eller via chat på nettsiden.

Vi håper du var fornøyd med bestillingsprosessen og leveransen av produktet. Vi er opptatt av å kontinuerlig forbedre våre produkter og setter stor pris på tilbakemeldinger!

Lykke til med monteringen!

Trinn 1:

Monter platene ③x4 til bunnen av søylene med ①x16 med en elektrisk drill eller en sekskantnøkkel.

① x 8	
③ x 2	
ⓓ1 x 1	
ⓓ2 x 1	

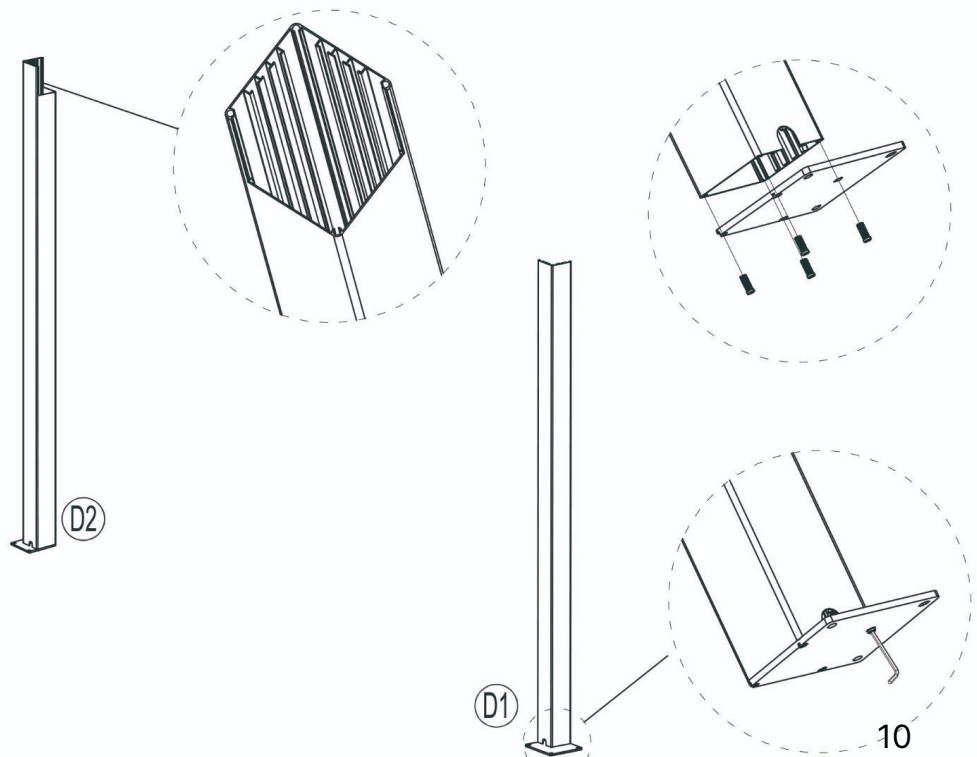



Trinn 2:

Legg søylene **D1** og **D2** ned (vær forsiktig slik at søylene ikke blir ripet)

Monter bjelkene **B1** og **B2** fast til søylene. Legg merke til at skruene som skal benyttes for innfesting av bjelken allerede er skrudd fast til søylene. Disse må derfor løsnes før montering.

Ikke stram skurene før takrennene er montert (trinn 7)

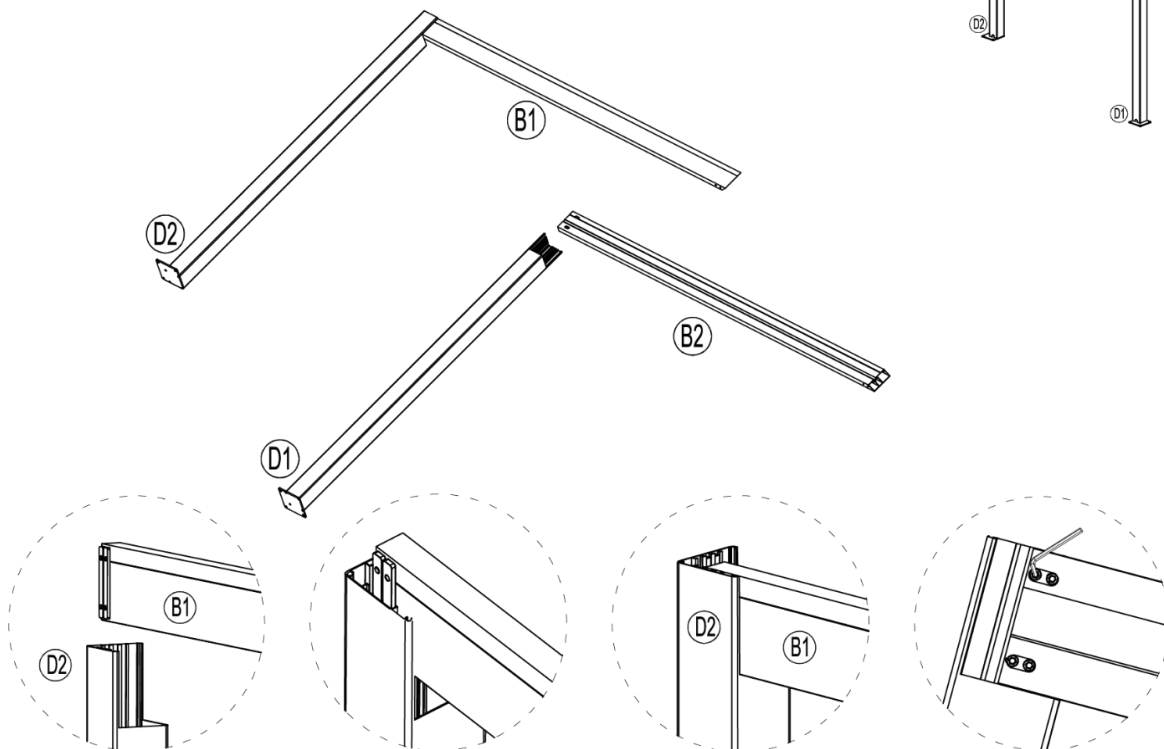
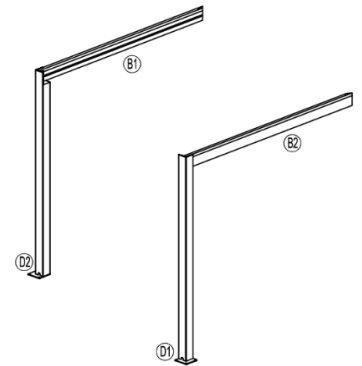

B1	x1	
B2	x1	



Trinn 3:

Plasser brakettene ⑨ i høyde 235cm fra bakken til underkant av brakettene. Avstanden mellom brakttene skal være 112cm.

Fest brakettene ⑨ med ②.

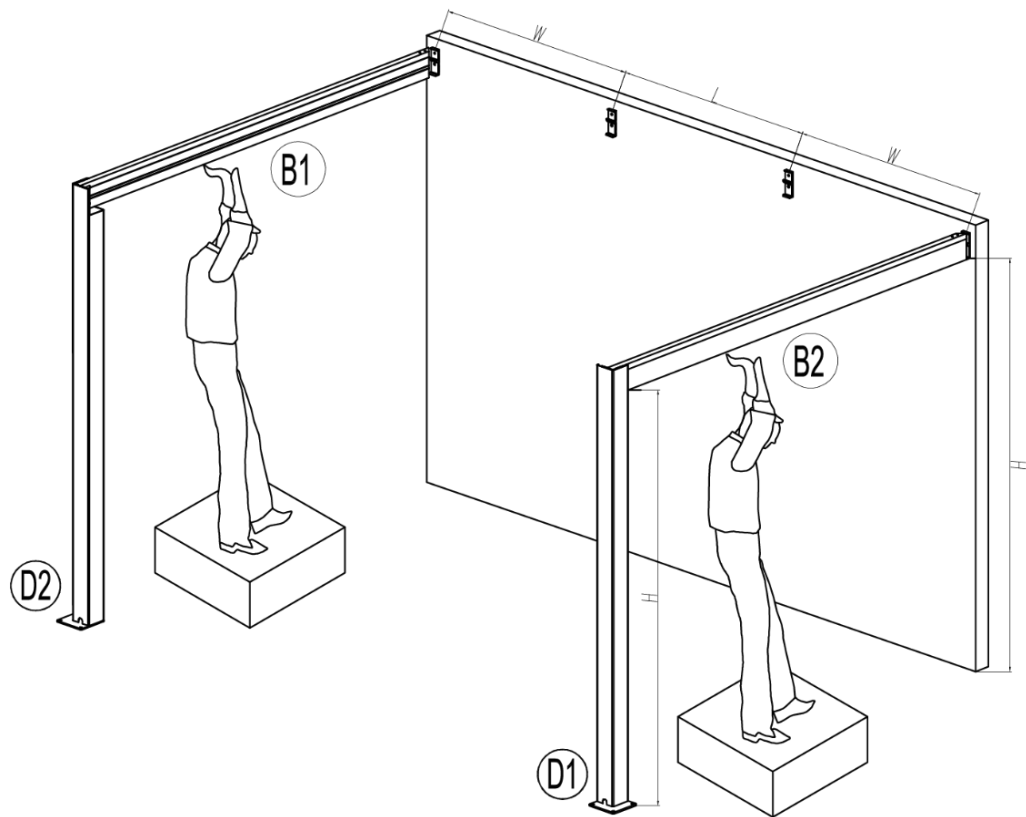
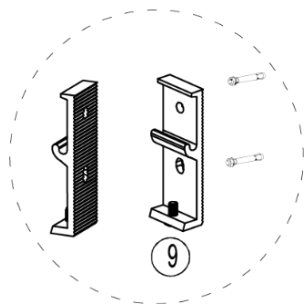

		
300x300	②x6	⑨x3
300x400	②x8	⑨x4
400x400	②x8	⑨x4



Trinn 4:

Heng veggbjelken **A2** i brakettene.

Sett **11** inn i veggbjelken. Fest sammen med skruene.



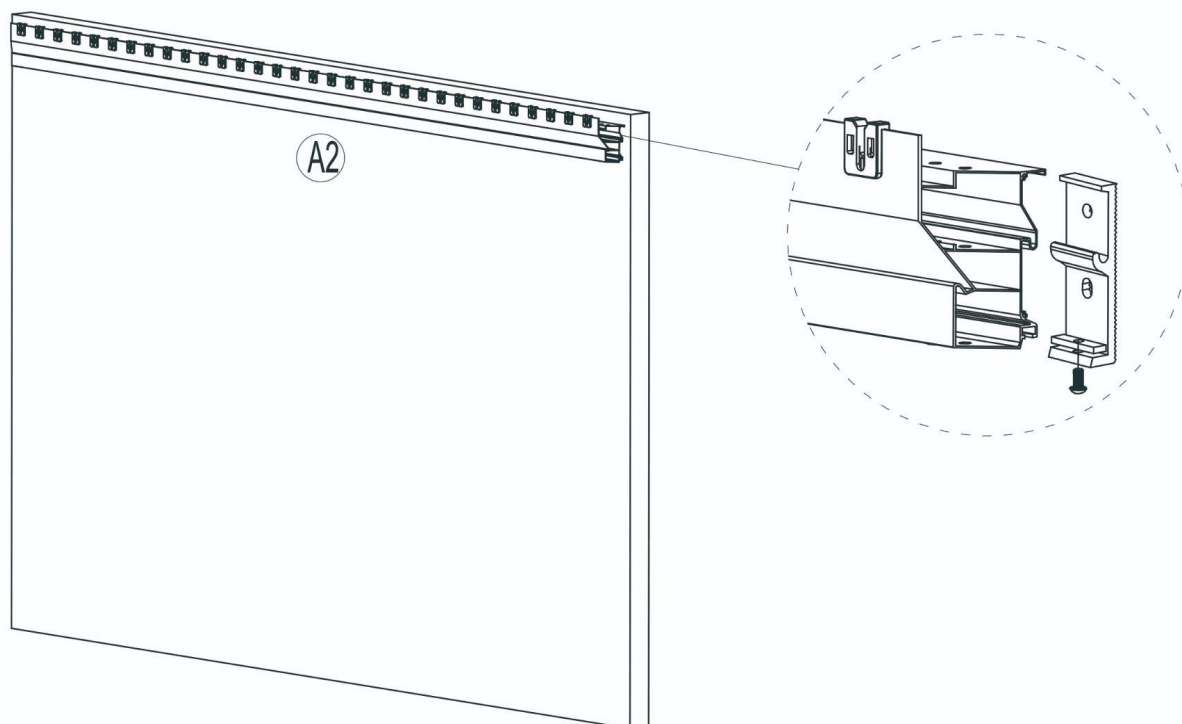

11 x 4	
	 M8X16
A2 x 1	



Trinn 5:

Sett bjelken (B1) → (A1). Gjør det samme med bjelken (B2) → (A1)

Ikke stram skruene (1) før takrennene er montert (trinn 7).

(1) x 6	
(4) x 2	
(B1) x 1	
(B2) x 1	

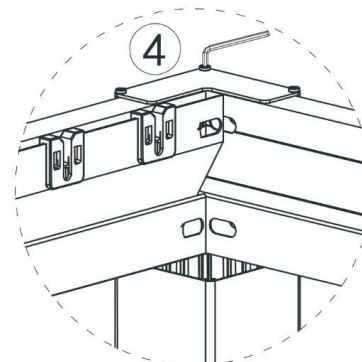
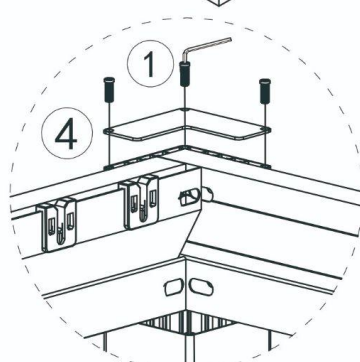
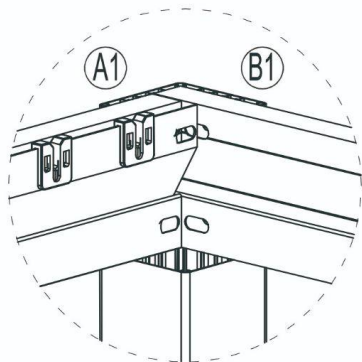
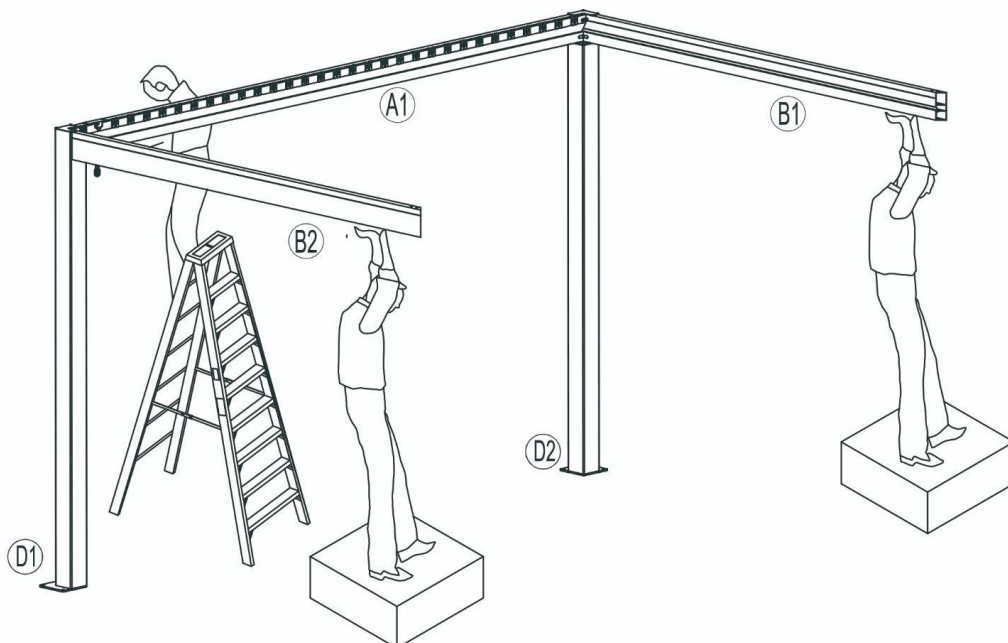





Trinn 6:

Fest sammen bjelkene (B1) → (A2) og (B2) → (A2) med topp-platene (10).

Fest ende-dekselene (12).

Ikke fest skruene før takrennene er montert (trinn 7)

(12) x 4	 ST4.2X25
(12) x 2	
(18) x 16	
(10) x 2	

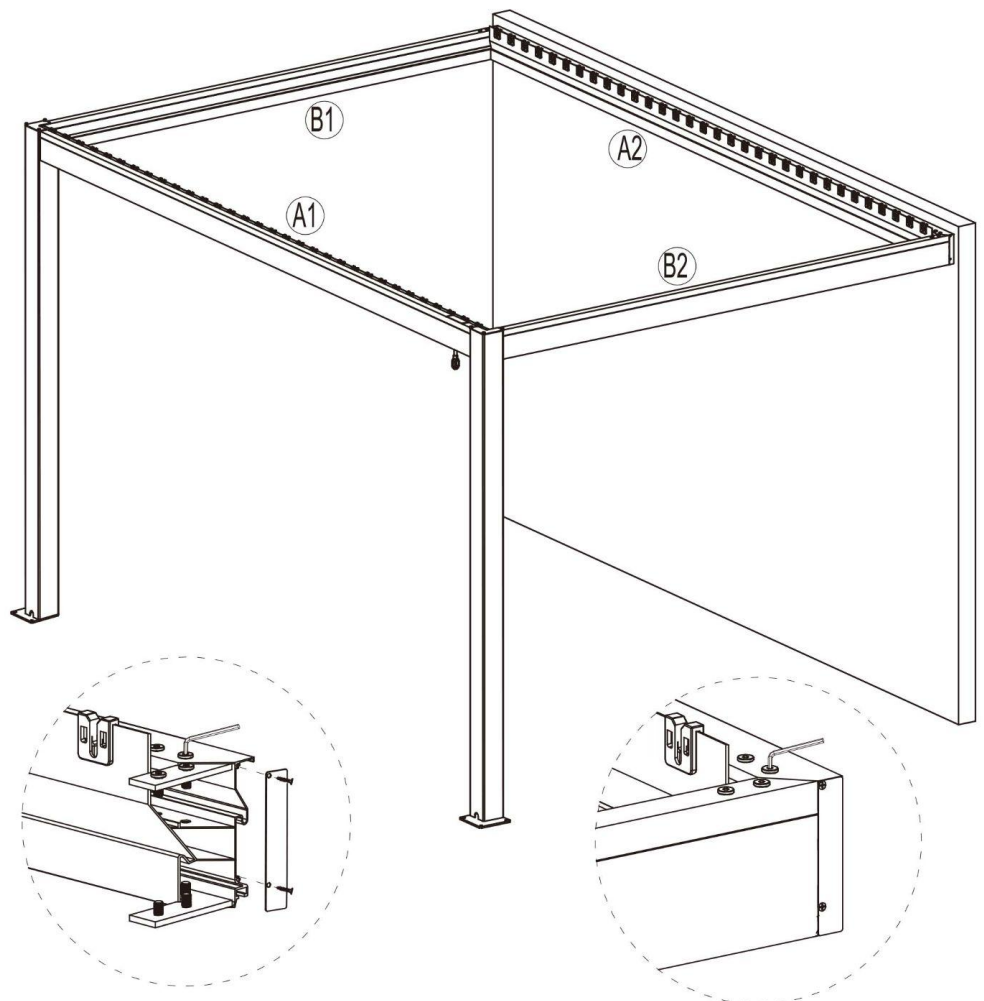







Trinn 7:

Skyv 2x⑯ inn i takrennene ① ② ③ ④ for montasje av tileggsprodukter.

Heng takrennene på bjelkene som vist nedenfor.

Skru dem fast med skruene ⑰.

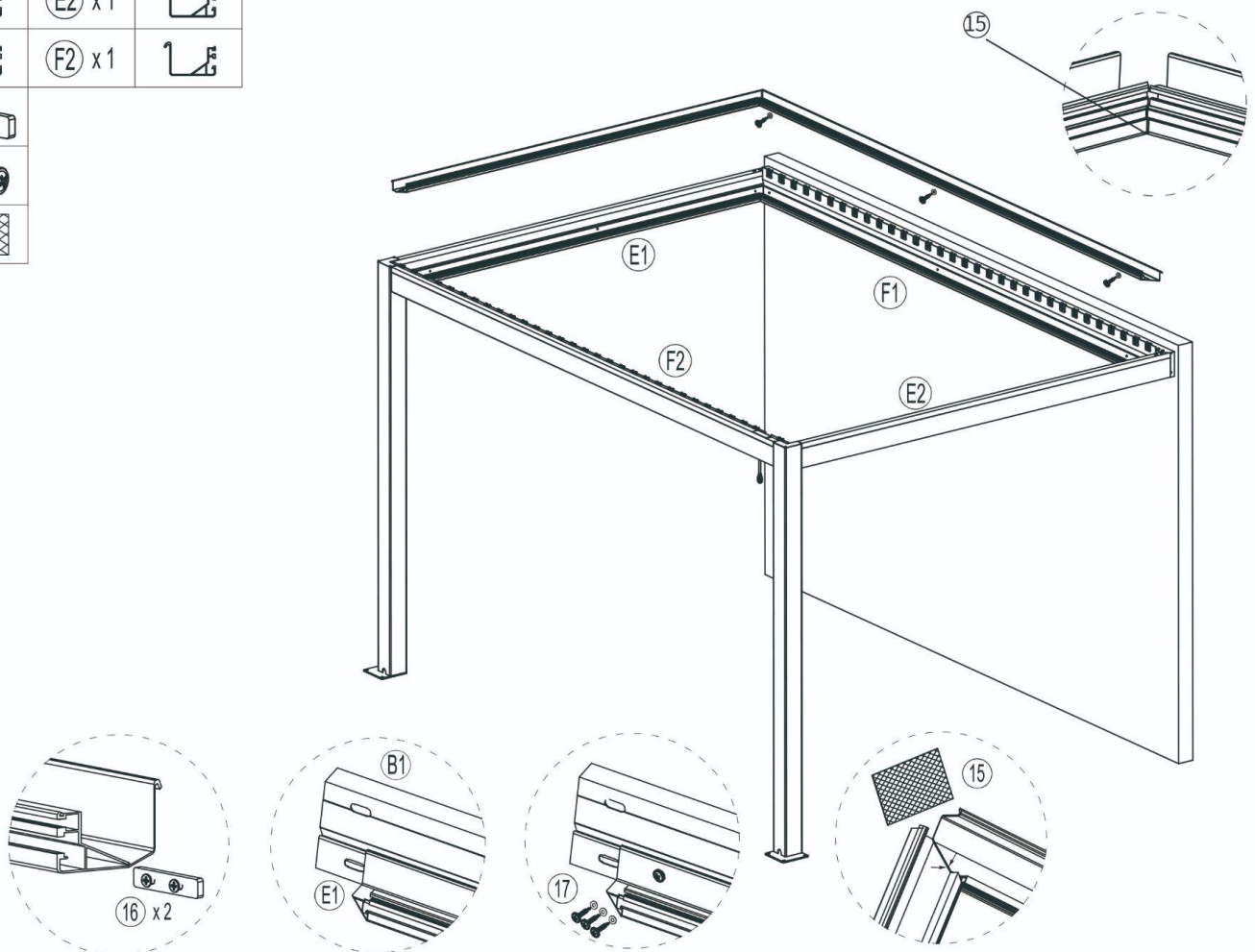

① x 1		② x 1	
③ x 1		④ x 1	
⑰ x 8			
⑱ x 12			
⑲ x 4			



Trinn 8:

Sett inn styrelamellen (H)x1 på den andre raden som vist nedenfor. Bruk gjerne litt kraft for å få den inn.

Monter deretter de andre lamellene i rekkefølge.



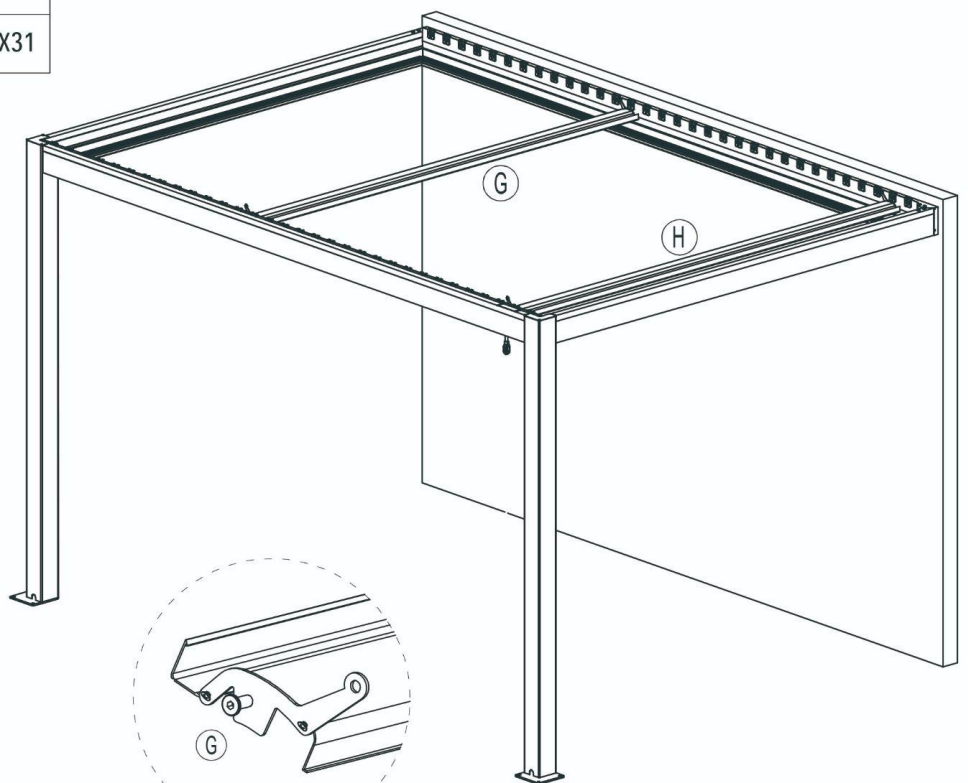
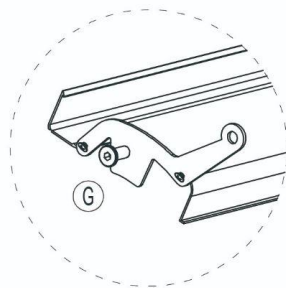
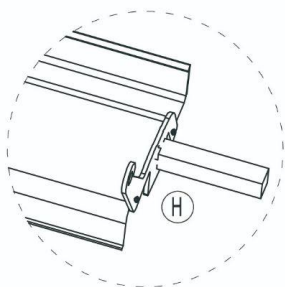

300X300		(H) X1	(G) X22
300X400		(H) X1	(G) X31
400X400		(H) X1	(G) X31



Trinn 9:

Fest lamellene og styringsskinnen (J) med (5), (6), (7) som vist nedenfor.

Stram skruene til med en sekskantnøkkel.

				
300X300	(5) X46	(6) X46	(7) X46	(J) X2
300X400	(5) X64	(6) X64	(7) X64	(J) X2
400X400	(5) X64	(6) X64	(7) X64	(J) X2

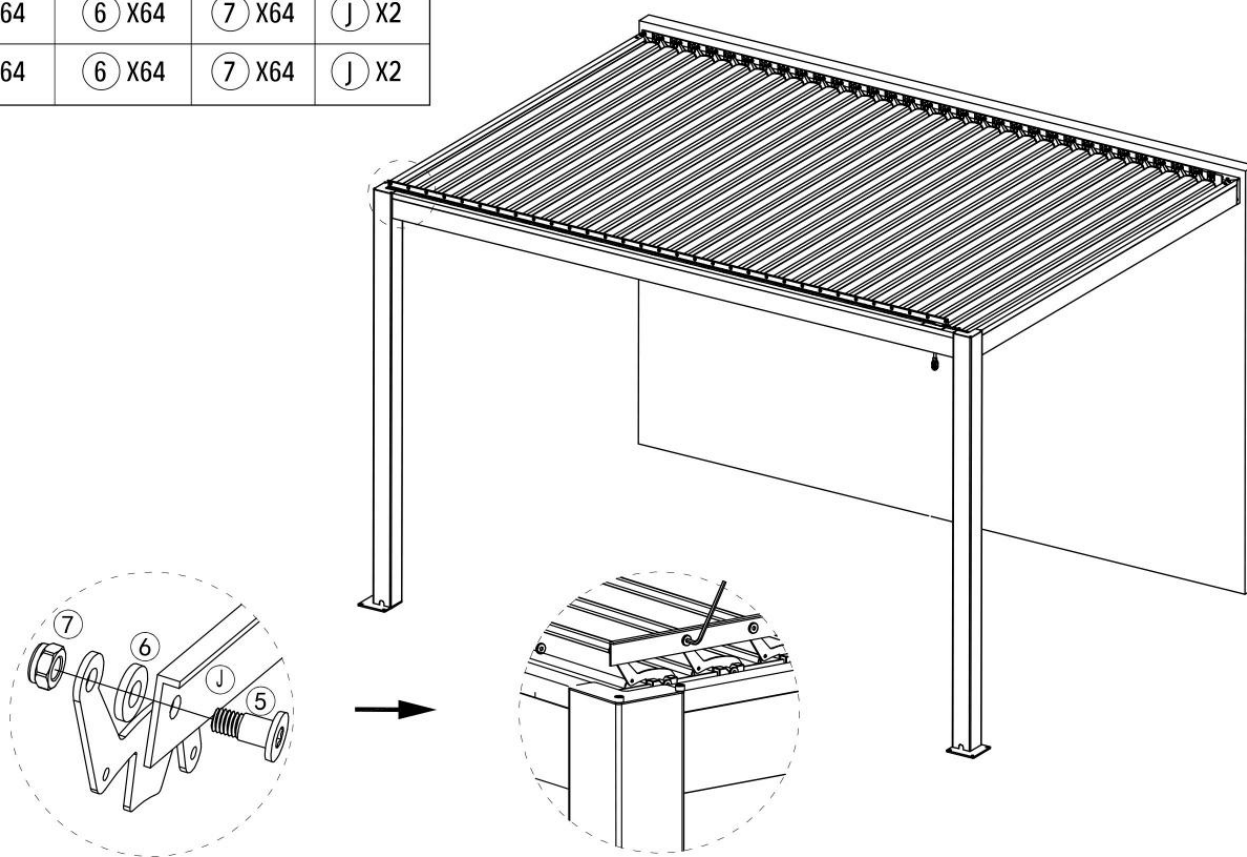

Trinn 10:

Du kan nå feste pergolaen til underlaget. Egnede festemidler kan kjøpes hos din nærmeste byggevareforhandler. Påse at du ikke skrur igjennom membraner etc.

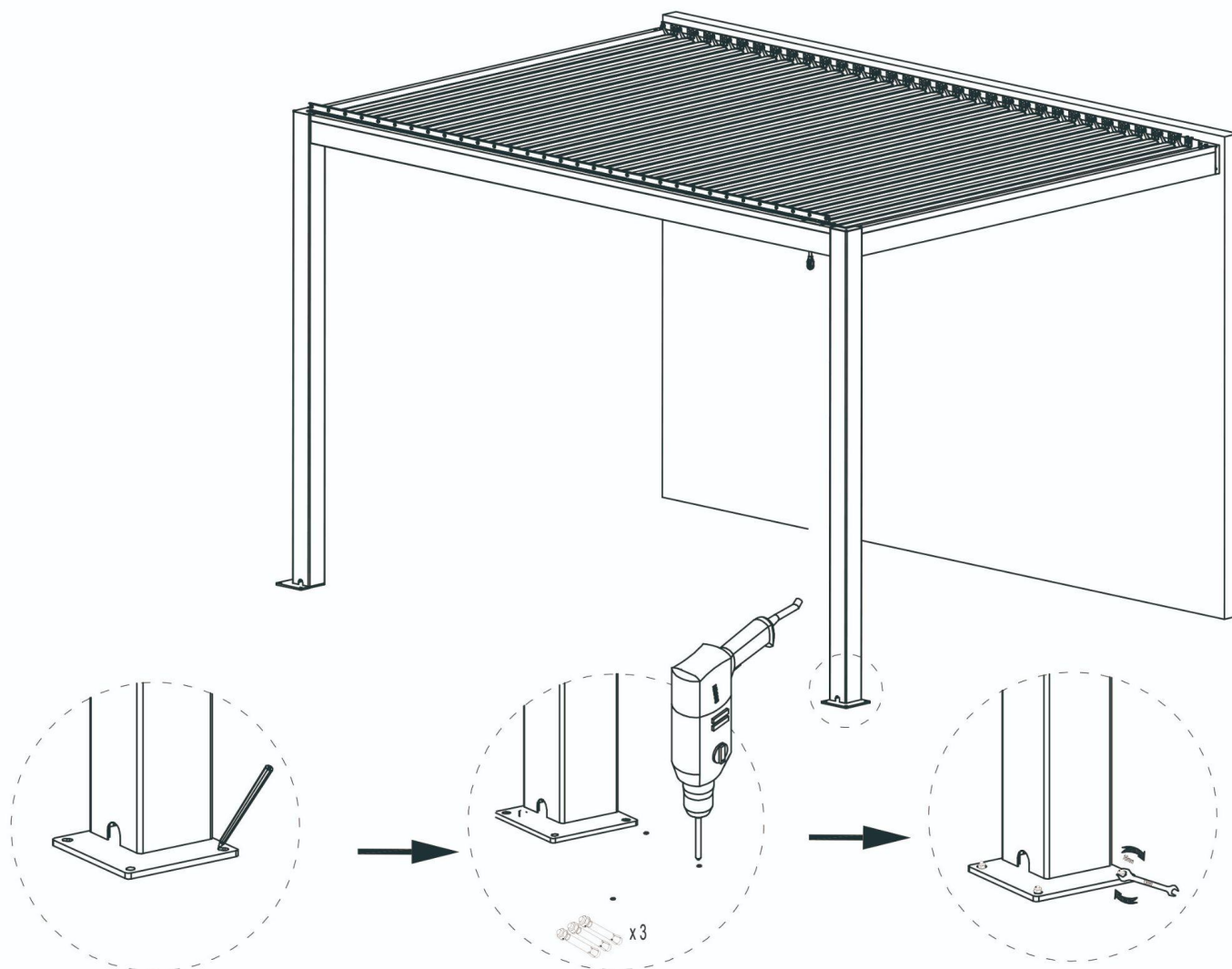

Trinn 11:

Monter stormsikringsplatene ⑬ og ⑭ på bjelkene med skruer:

⑬ x2		
⑭ x2		

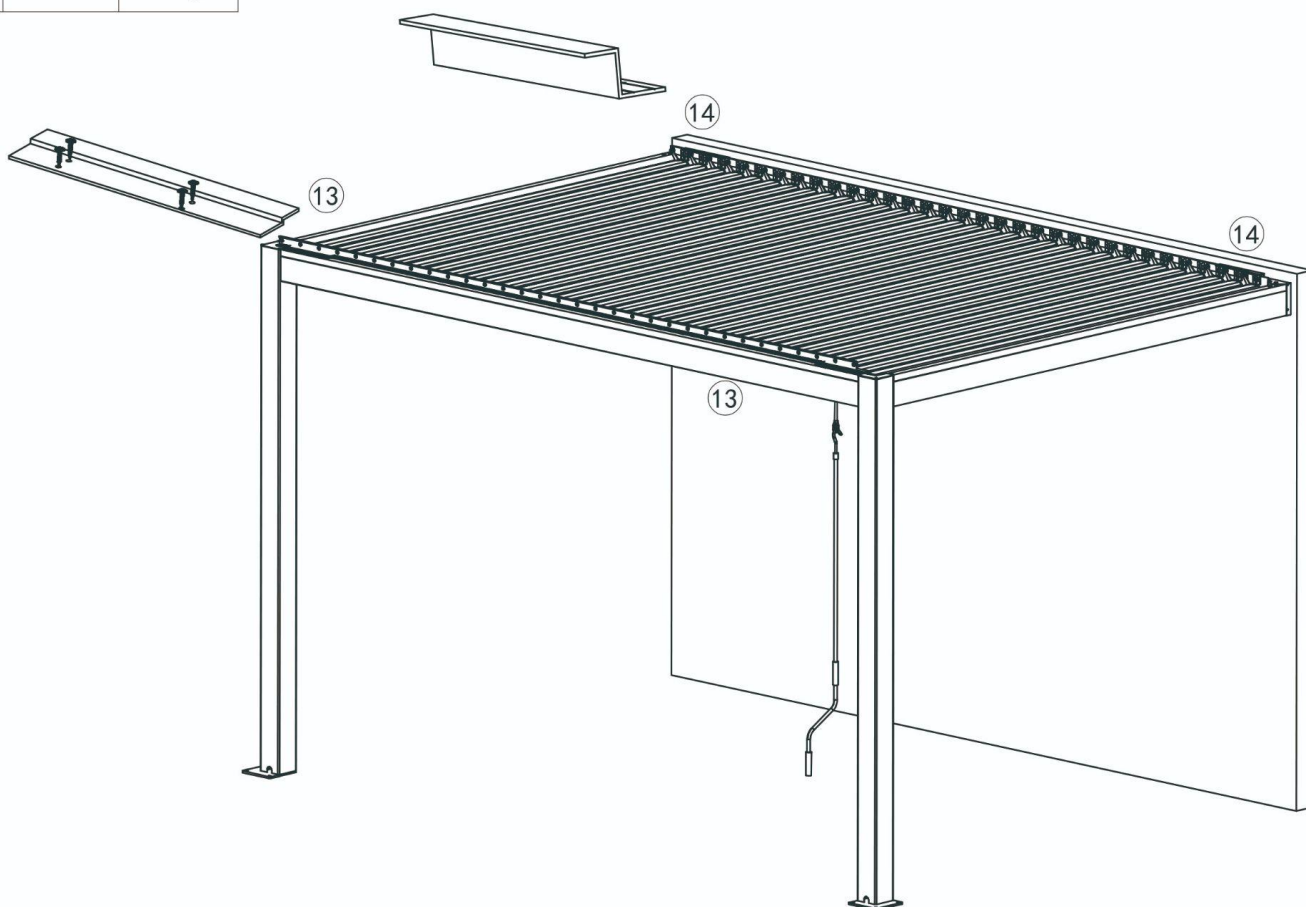

Installation:

Dear Customer,

Congratulations and thank you for choosing our PERGOLUX pergola.





Before you start assembling the pergola, use the product list to check that the individual packages are complete. Please note that some screws are already pre-assembled. If the packaging or the pergola has visible damage, take a picture of it and contact us immediately at customerservice@pergolux.com or via the chat on our website.

We hope you are satisfied with the ordering process, the delivery, the assembling instructions and the product itself. We want to continuously improve our service and product and we welcome your feedback!

Good luck with the assembling the product!

Step 1:

Install the plates ③x4 to the bottom of the pillars with screws ①x16 using an electric drill or a hex key.

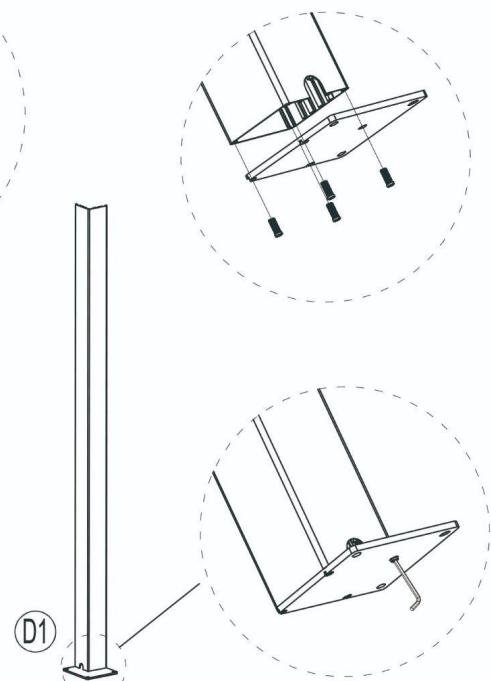
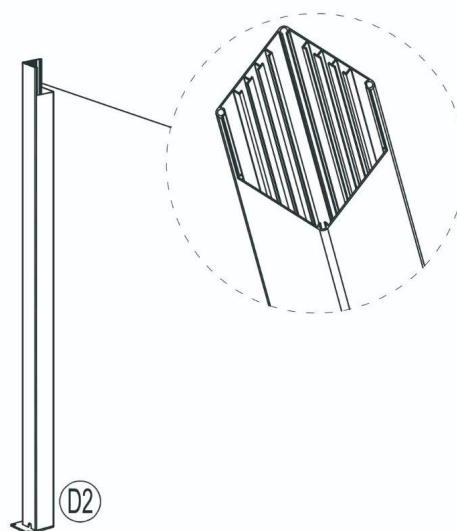

① x 8	
③ x 2	
ⓓ1 x 1	
ⓓ2 x 1	



Step 2:

Lay the pillars (D1) and (D2) down and insert the beams (B1) and (B2).

Do not tighten the screws until the gutter (step 7) are installed.

(B1)	x1	
(B2)	x1	

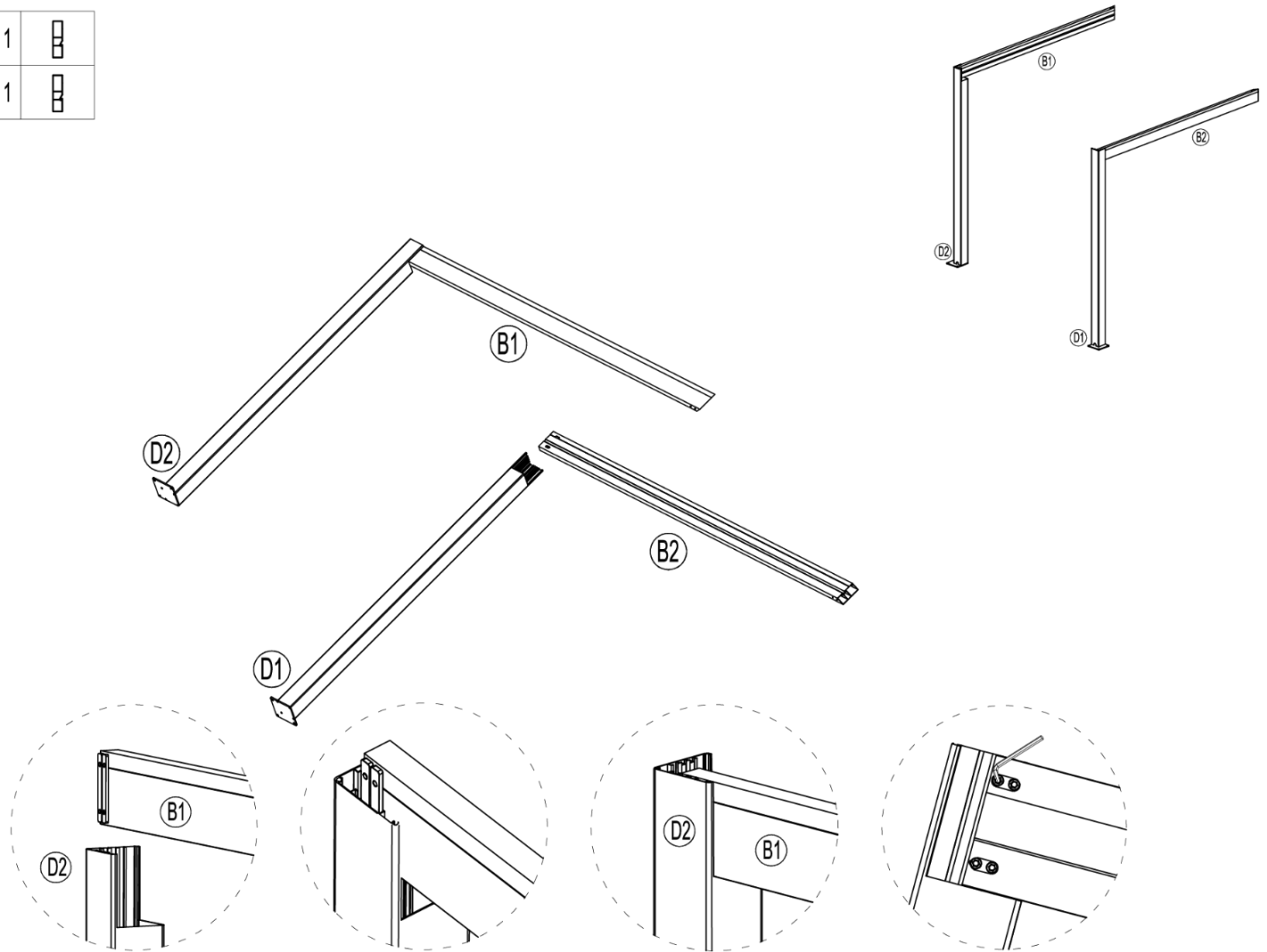

Step 3:

Fasten the brackets (9) 235cm from the ground to the lower edge of the brackets. The distance between the brackets must be 112cm.

Fasten the brackets (9) with (2).

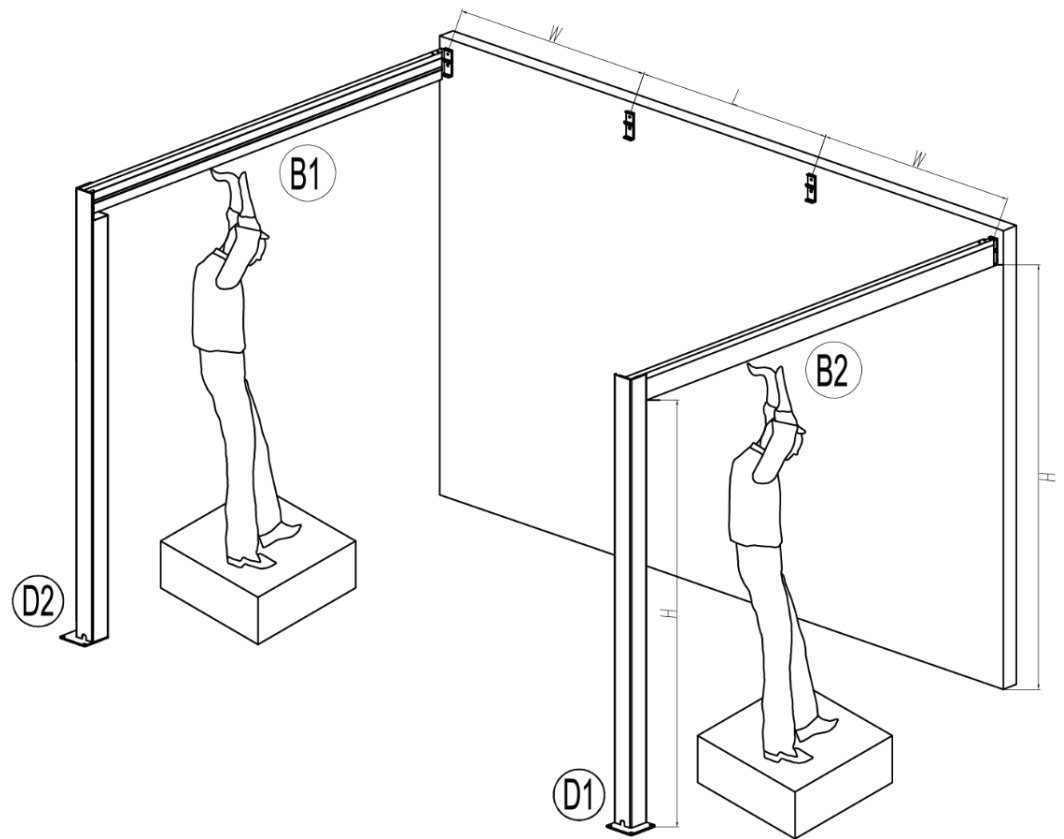
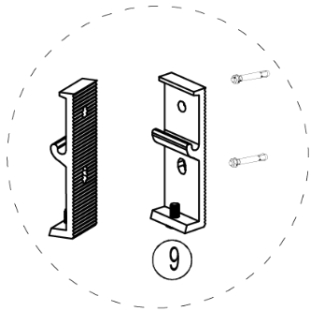

300x300	(2)x6	(9)x3
300x400	(2)x8	(9)x4
400x400	(2)x8	(9)x4



Step 4:

Hang the wall beam **A2** into the bracket and insert **11** into the wall beam.

Fasten with screws.



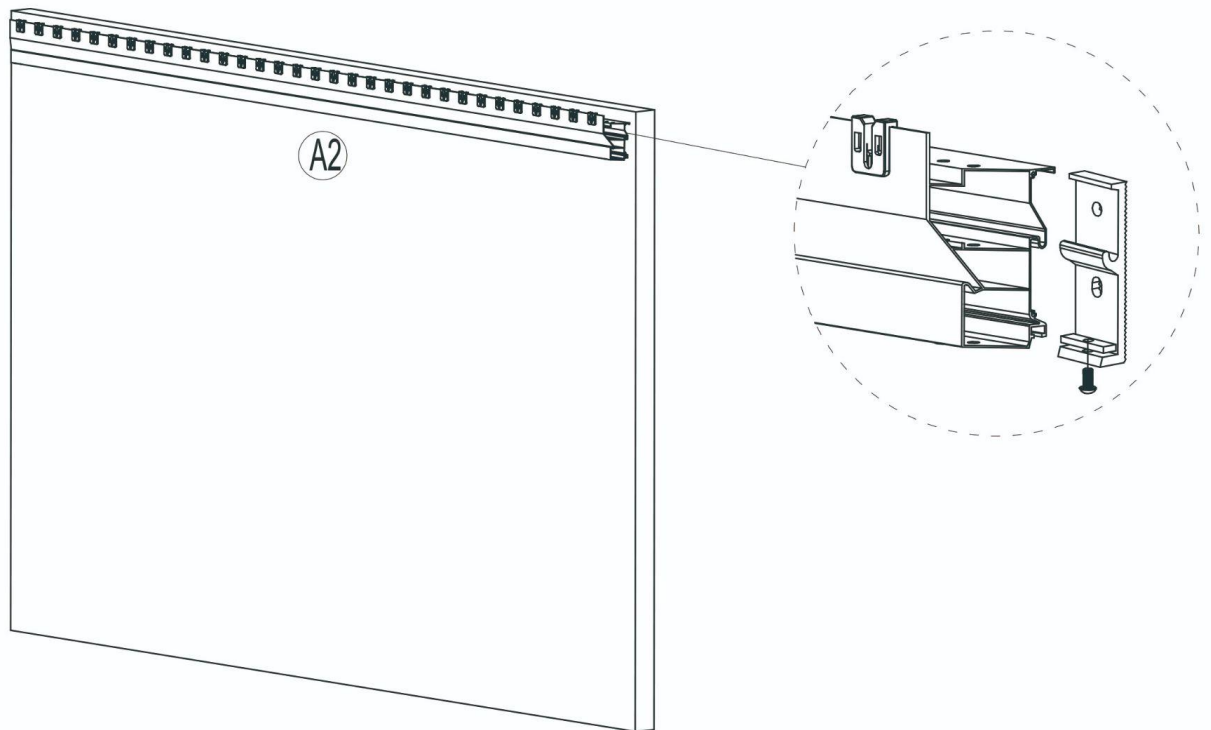

11 x 4	  M8X16
A2 x 1	



Step 5:

Insert the beams **B1** and **B2** into **A1**.

Do not tighten the screws **1** until the gutters are installed (step 7).

1 x 6	
4 x 2	
B1 x 1	
B2 x 1	

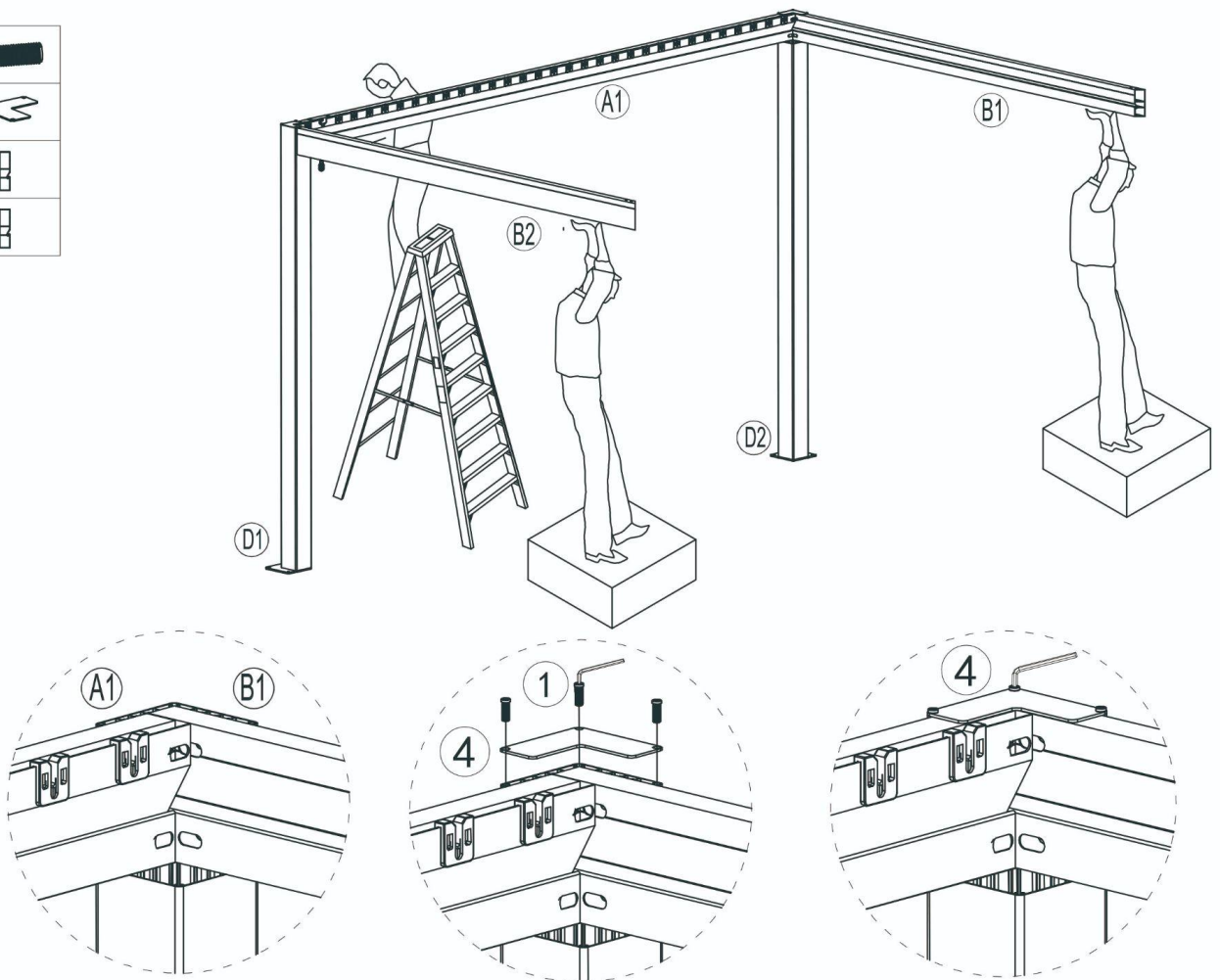





Step 6:

Connect (B1) → (A2) and (B2) → (A2) with (10).

Attach the end covers (12).

Do not tighten the screws until the gutters are installed (step 7).

(12) x 4	 ST4.2X25
(12) x 2	
(18) x 16	
(10) x 2	

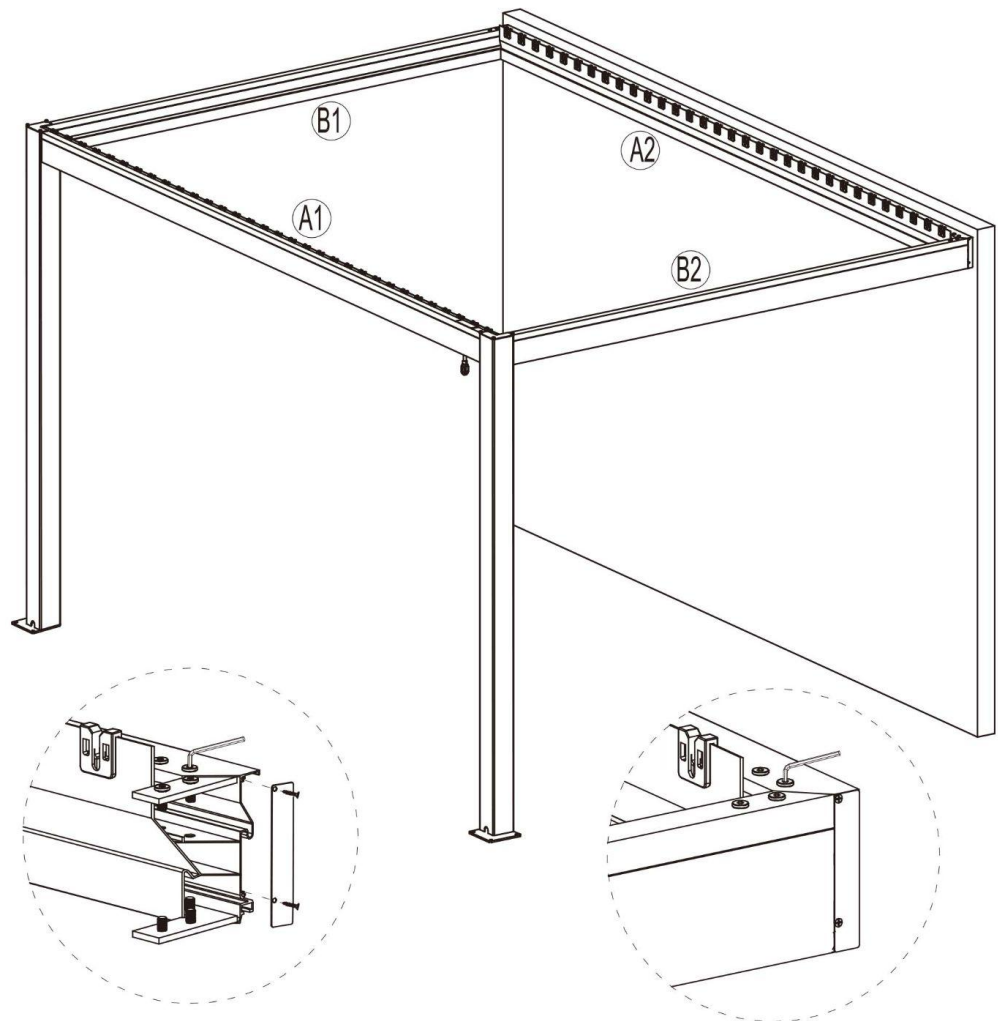







Step 7:

Insert ⑩x2 into the gutter ①E1 ①E2 ①F1 ①F2 for installing heaters.

Hang the gutters
onto the beams as seen below.

Screw them together with the beams by using ①7 screws

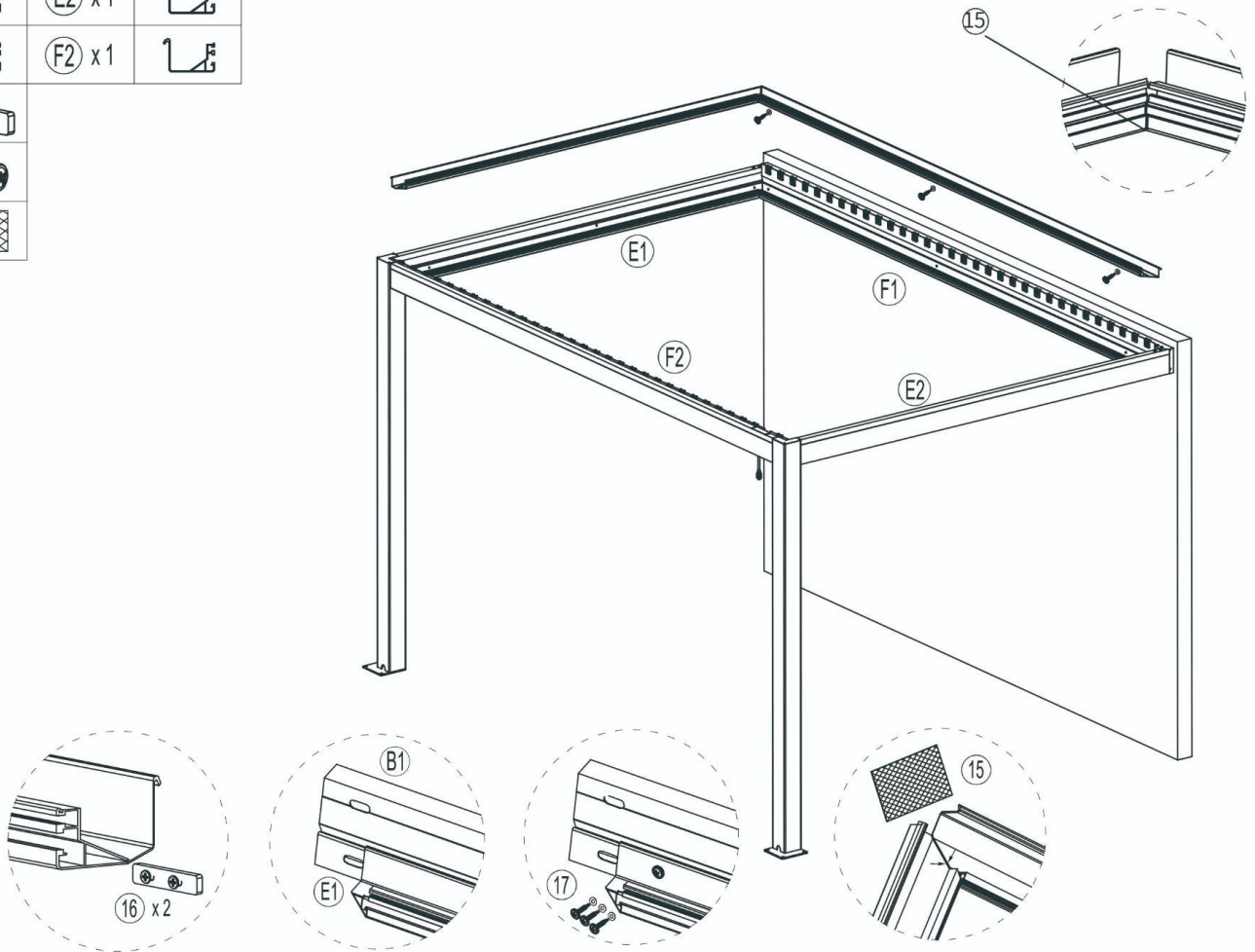

①E1 x1		①E2 x1	
①F1 x1		①F2 x1	
①6 x8			
①7 x12			
①5 x4			



Step 8:

Insert the steering slats (H)x1 on the second row.

Proceed by installing the other slats in order.



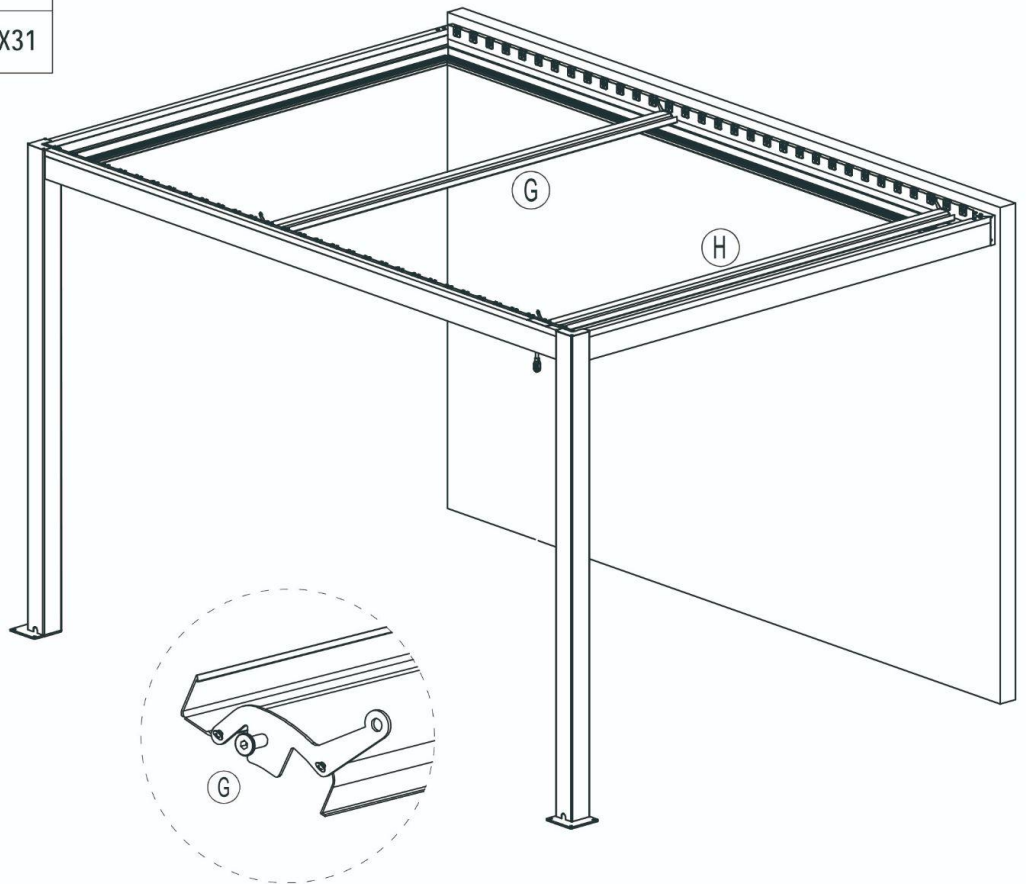

300X300		(H) X1	(G) X22
300X400		(H) X1	(G) X31
400X400		(H) X1	(G) X31



Step 9:

Connect the slats and the steering rail (J) with (5) (6) (7) as seen below.

Continue by tightening the screws with a hex key.

				
300X300	(5) X46	(6) X46	(7) X46	(J) X2
300X400	(5) X64	(6) X64	(7) X64	(J) X2
400X400	(5) X64	(6) X64	(7) X64	(J) X2

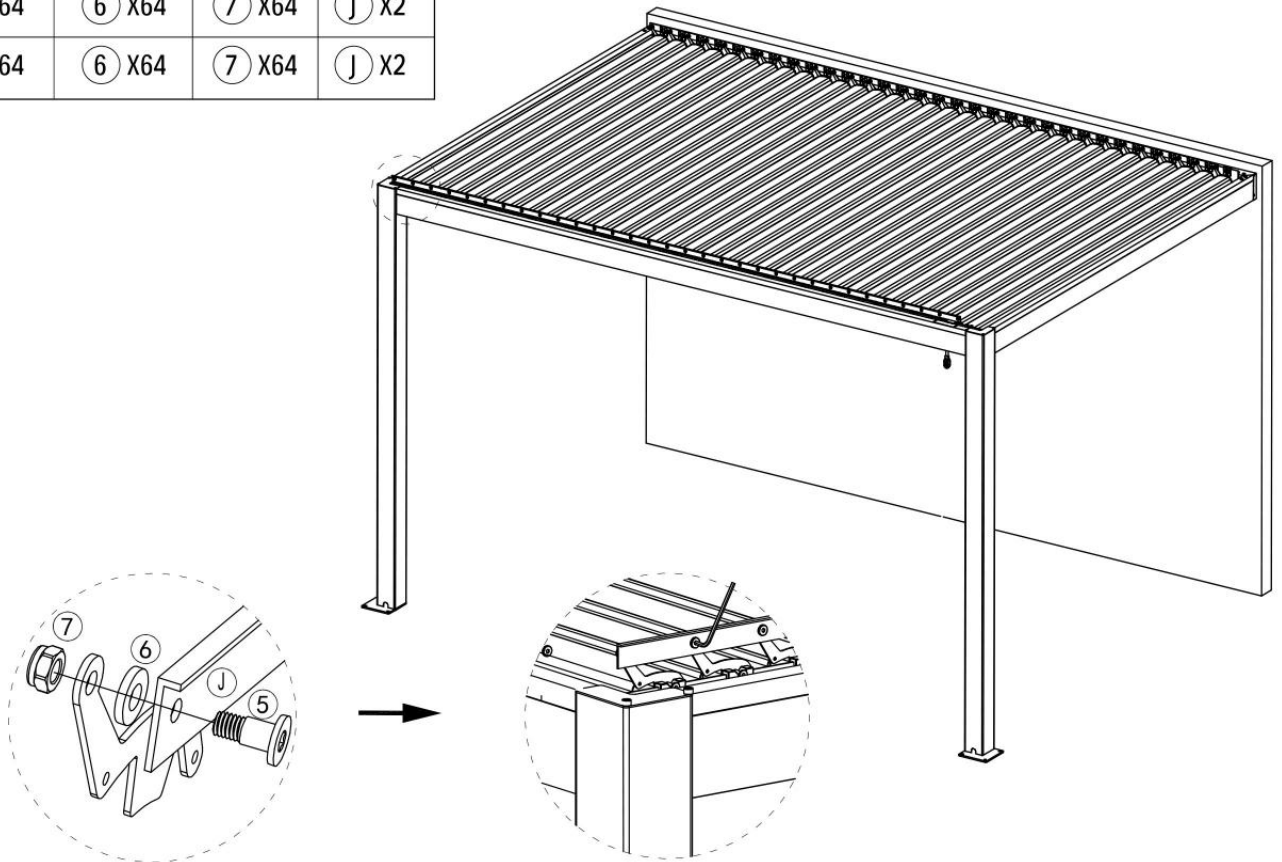

Step 10:

You can now attach the pergola to the ground. Suitable fasteners can be purchased from a building materials dealer. Be careful not to screw through membranes etc.

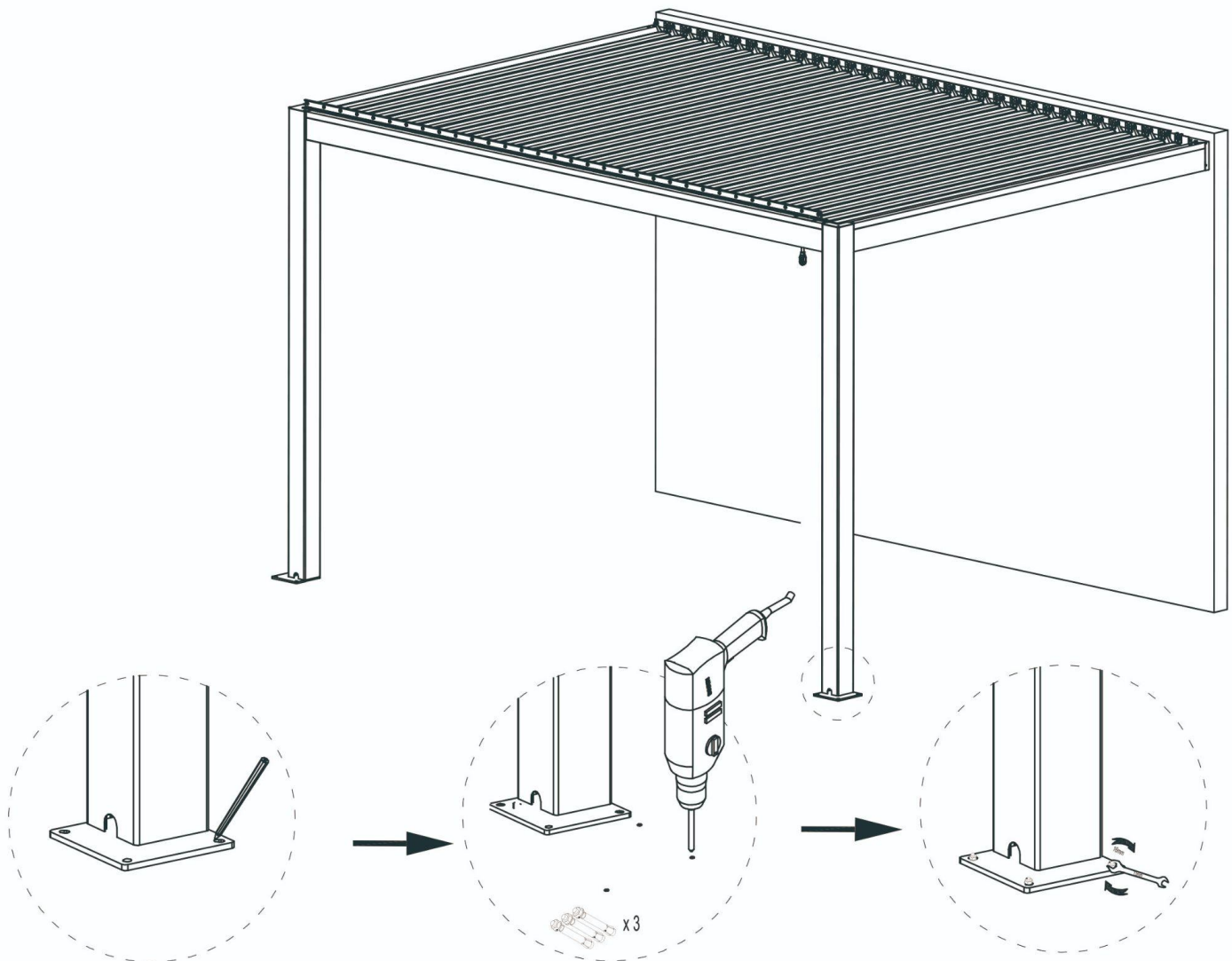

Step 11:

Install the wind protection plates ⑬ and ⑭ onto the beams with screws as seen below:

⑬ x2		
⑭ x2		

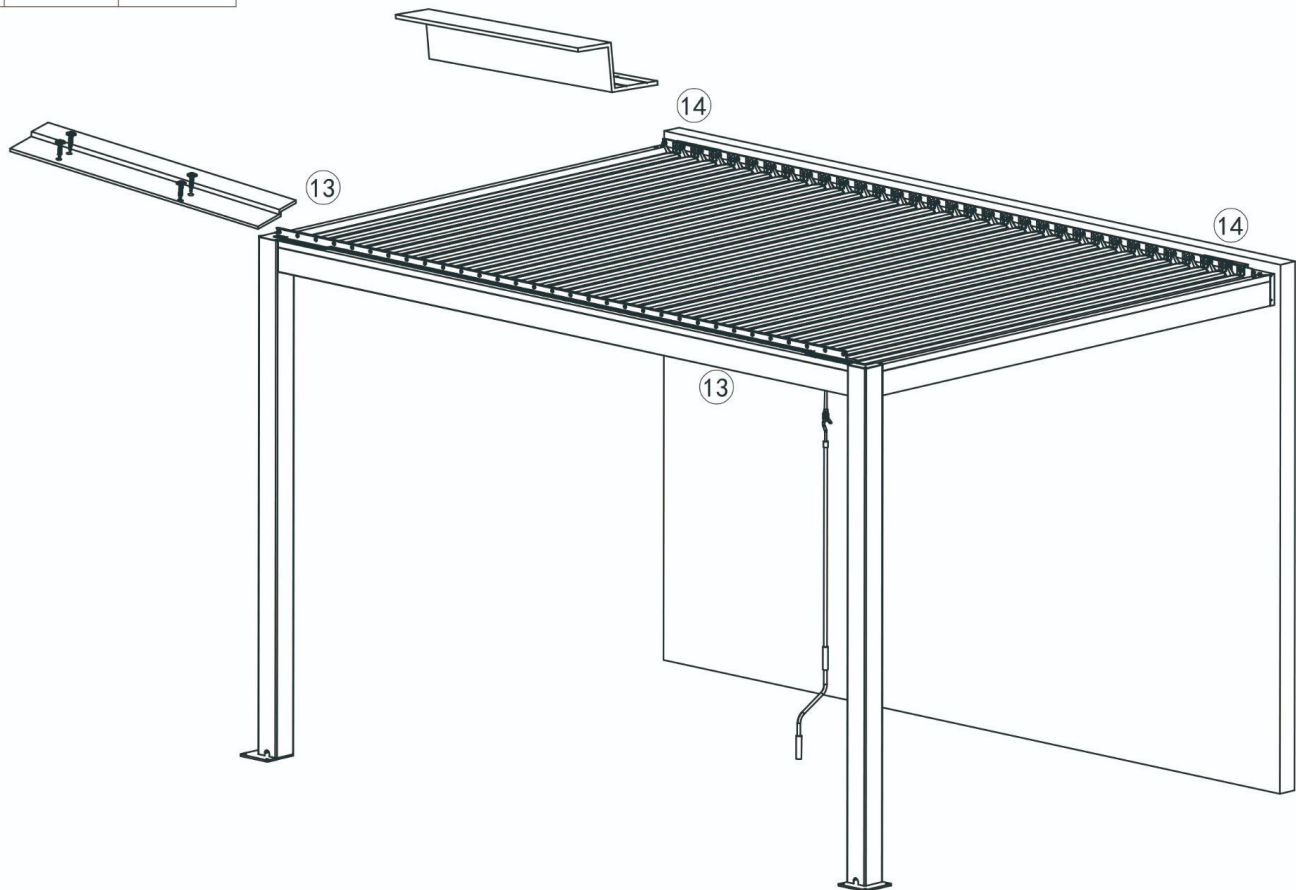

Montage:

Sehr geehrter Kunde,

herzlichen Glückwunsch und vielen herzlichen Dank, dass Sie sich für eine PERGOLUX Pergola entschieden haben. Bevor Sie mit der Montage beginnen, kontrollieren Sie anhand der Produktliste die einzelnen Pakete auf Ihre Vollständigkeit, bitte beachten Sie das bereits einige Schrauben vormontiert sind. Sollte die Verpackung oder die Pergola sichtbare Schäden haben, dann fotografieren Sie diese und kontaktieren Sie uns umgehend auf kundenservice@pergolux.de oder über den Chat auf der Webseite.

Wir hoffen, Sie waren mit dem Bestellvorgang, der Anlieferung, der Montage und dem Produkt richtig zufrieden. Wir möchten uns stetig verbessern und sind sehr an Ihrer Rückmeldung interessiert.

Viel Erfolg bei der Montage wünscht ihr PERGOLUX Team!

Schritt 1:

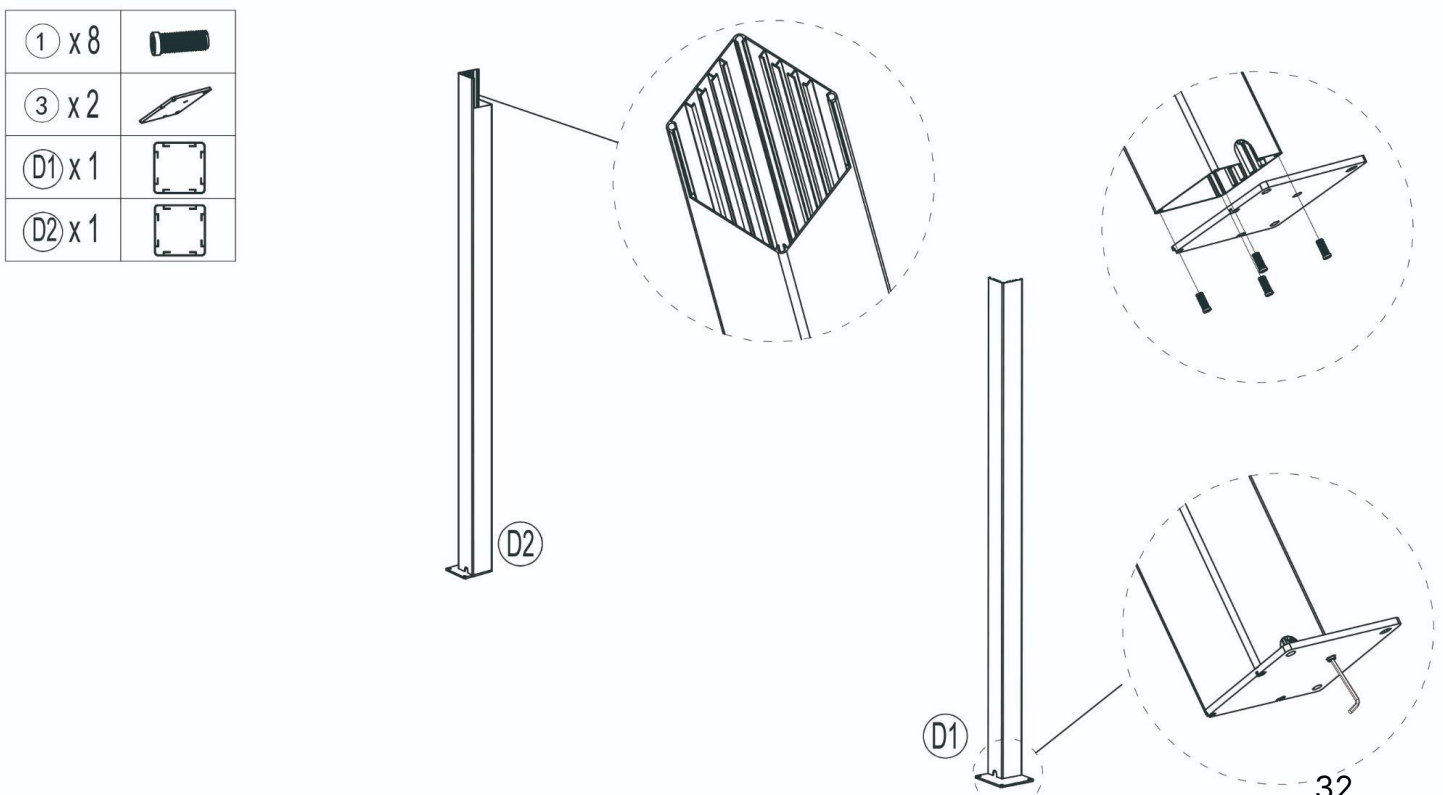

Installieren sie die Grundplatten ③x4 an der Unterseite der Säulen mit den Schrauben ①x16 ziehen sie die Schrauben fest.



Schritt 2:

Legen sie die Pfeiler (D1) und (D2) hin und setzen sie die Balken (A1) ein

Ziehen sie die Schrauben erst fest, wenn die Dachrinnen (Schritt 7) montiert sind.

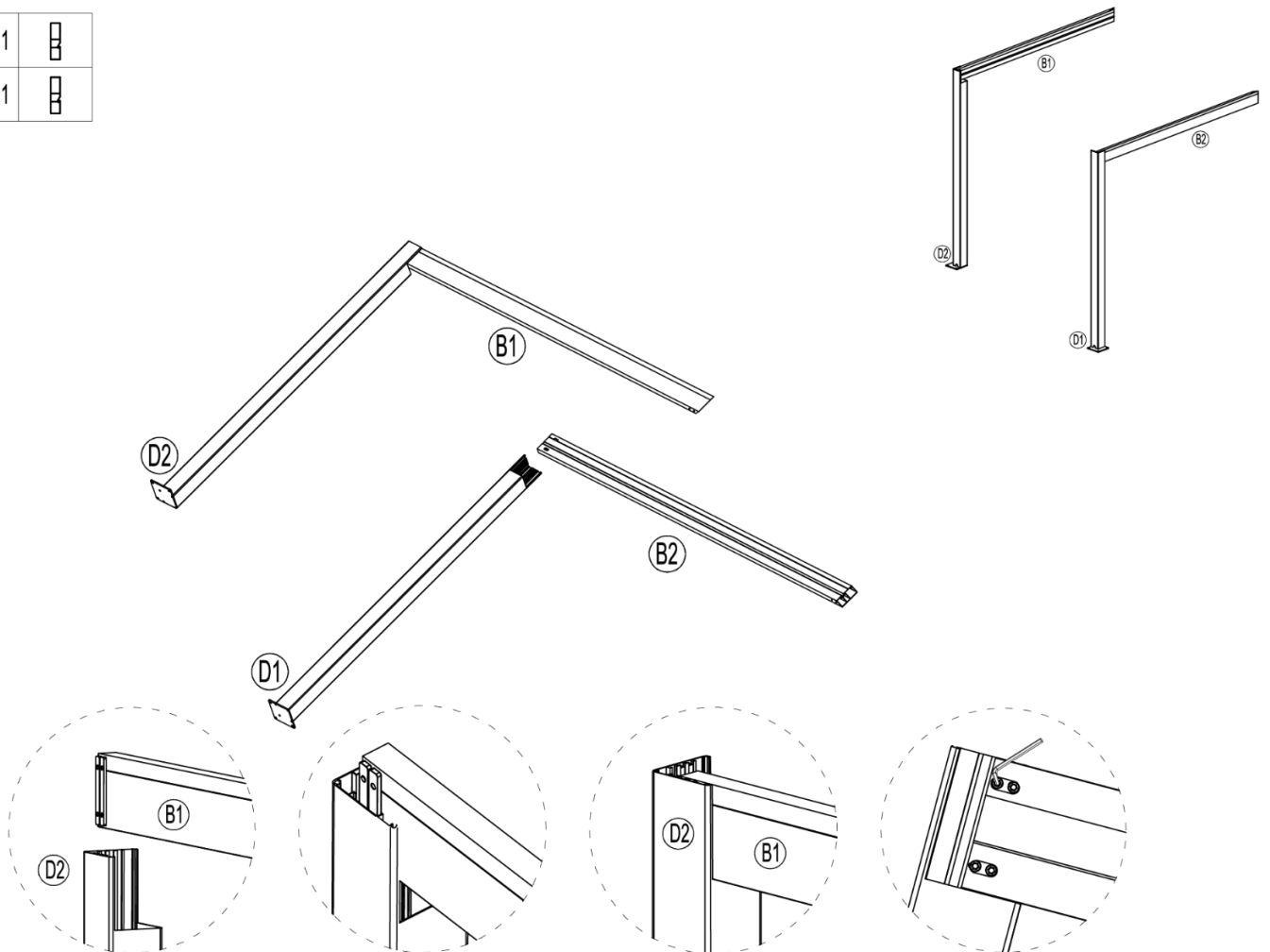

(B1)	x1	
(B2)	x1	



Schritt 3:

Befestigen sie die Halterungen ⑨ 235cm über dem Boden, gemessen bis zur Unterkante der Halterungen. Der Abstand zwischen den Halterungen muss 112cm betragen.

Befestigen sie die Halterung ⑨ mit den Schrauben ②.

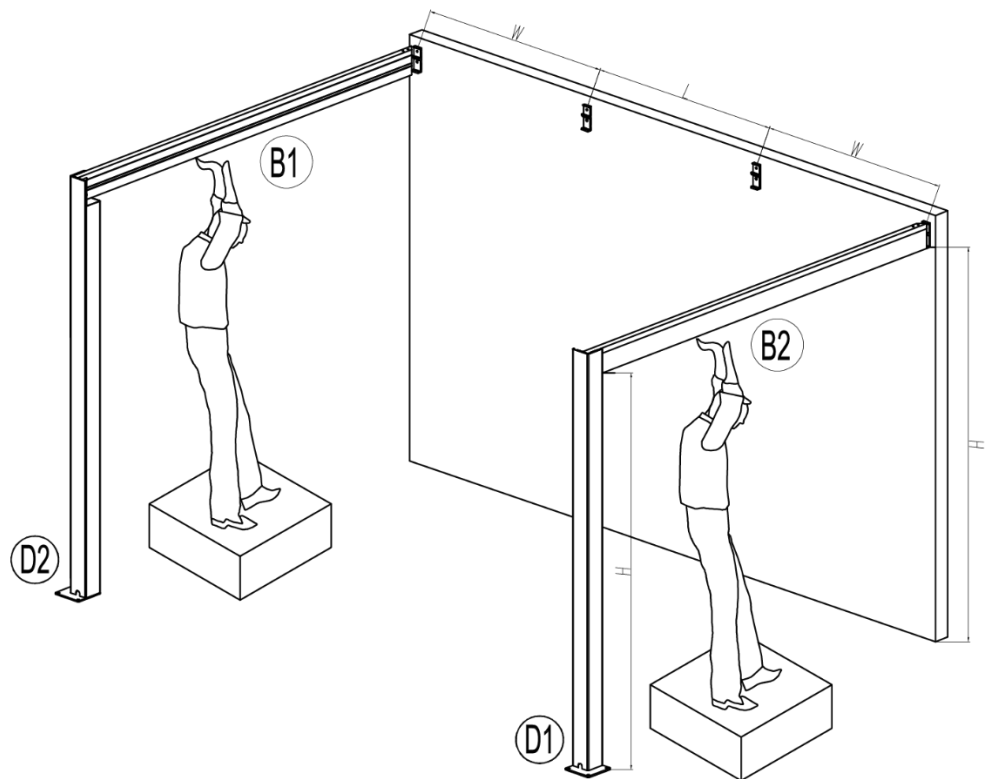
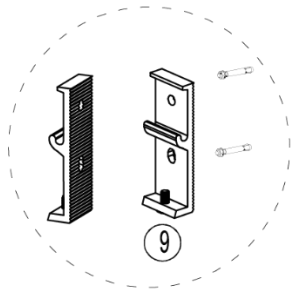

		
300x300	②x6	⑨x3
300x400	②x8	⑨x4
400x400	②x8	⑨x4



Schritt 4:

Hängen sie den Träger **A2** an die Halterung und setzen sie **11** in den Balken.

Ziehen sie die Schrauben fest.



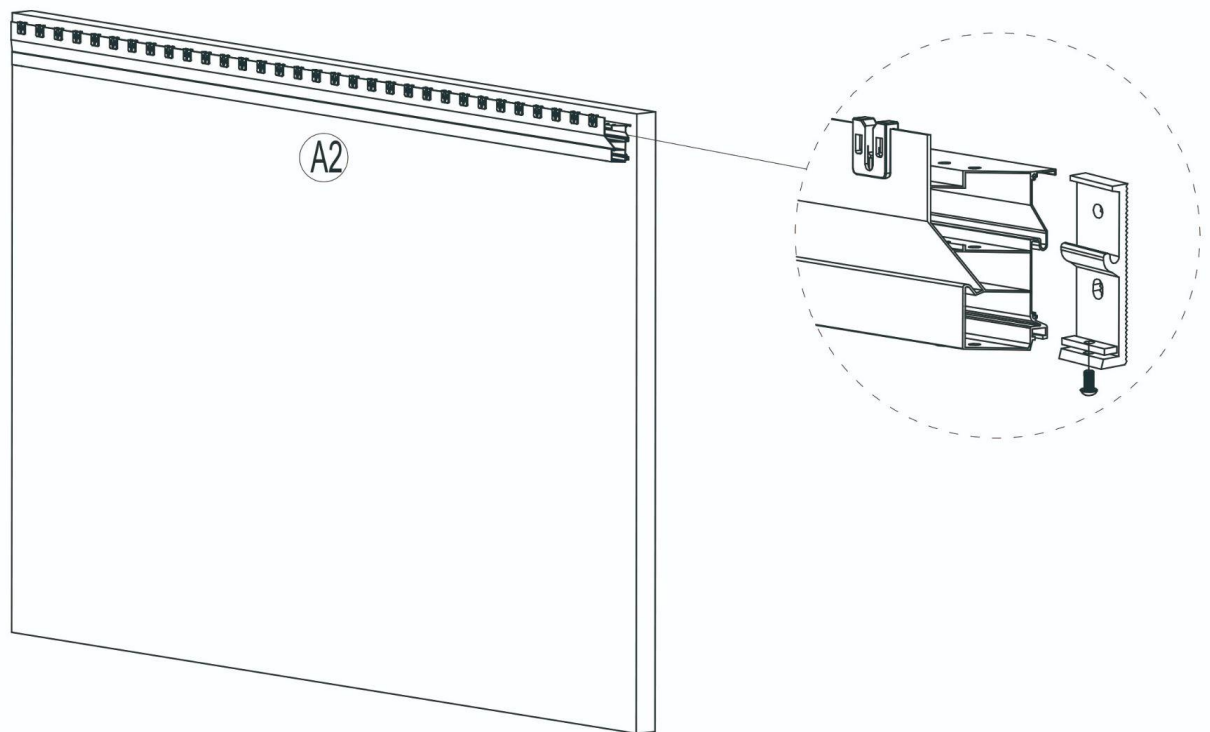

11 x 4	
	 M8X16
A2 x 1	



Schritt 5:

Setzen Sie die Balken (B1) und (B2) in (A1) ein.

Ziehen sie die Schrauben (1) erst fest, wenn die Dachrinnen (Schritt 7) montiert sind.



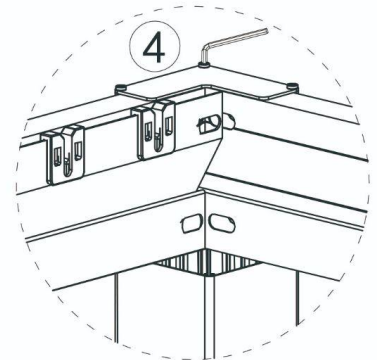
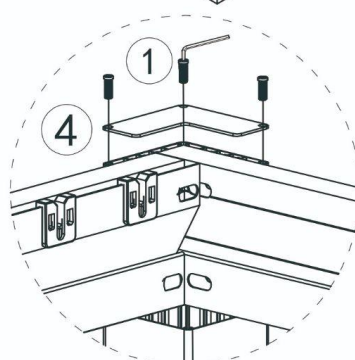
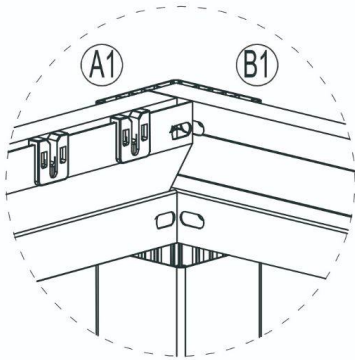
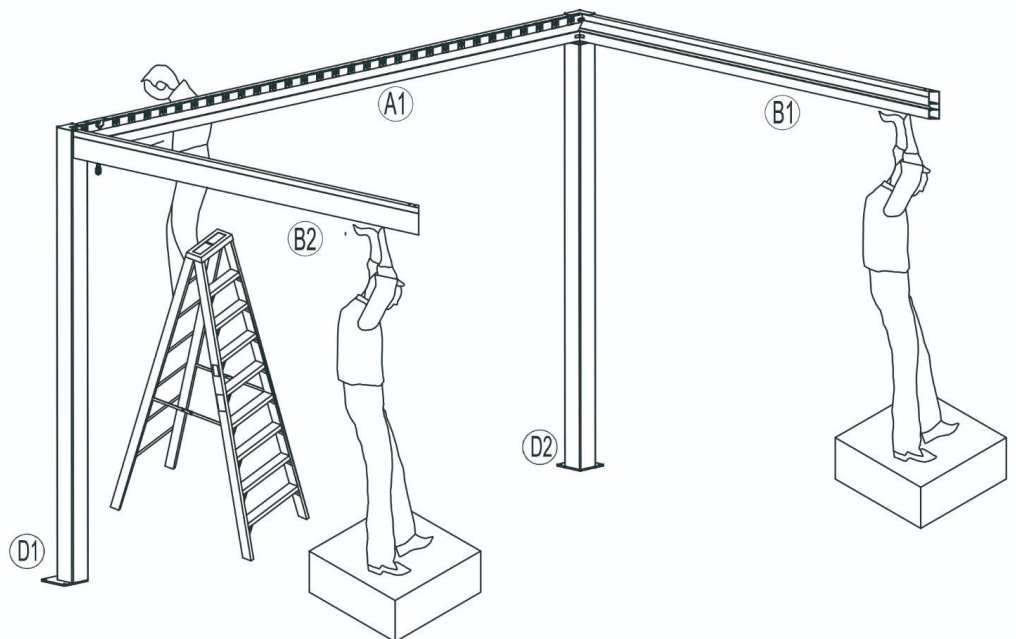

① x6	
④ x2	
(B1) x1	
(B2) x1	



Schritt 6:

Verbinden sie die Träger $\textcircled{B1} \rightarrow \textcircled{A2}$ und $\textcircled{B2} \rightarrow \textcircled{A2}$ mit den Eckverbindern $\textcircled{10}$.
Ziehen sie die Schrauben erst fest, wenn die Dachrinnen (Schritt 7) montiert sind.

Befestigen sie die Endkappen $\textcircled{12}$ mit den entsprechenden Schrauben.

$\textcircled{12}$ x 4	 ST4.2X25
$\textcircled{12}$ x 2	
$\textcircled{18}$ x 16	
$\textcircled{10}$ x 2	

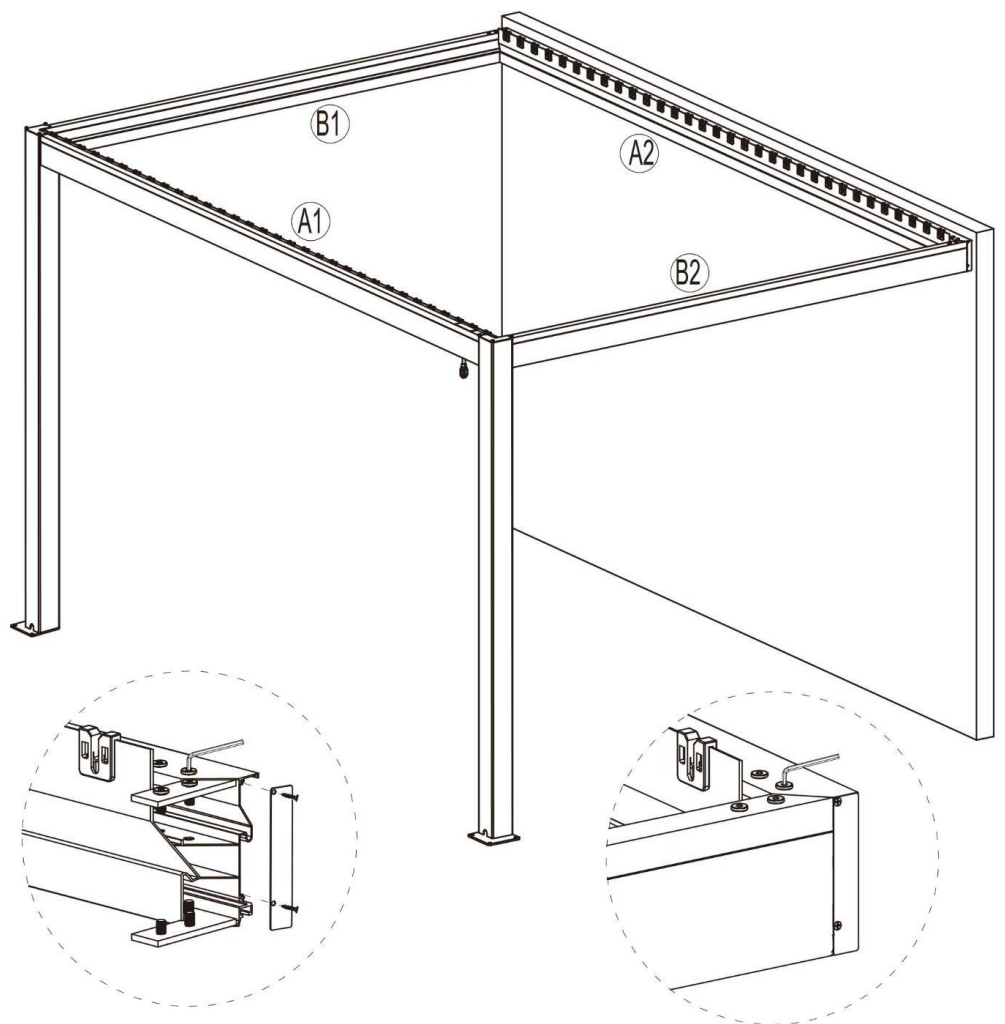







Schritt 7:

⑩x2 in die Dachrinnen (E1) (E2) (F1) (F2) zum Einbau von Heizungen einsetzen.

Hängen sie die Dachrinnen auf die Balken, wie auf dem Bild zu sehen ist.

Verschrauben sie diese mit den Balken. Nutzen sie die Schrauben ⑰ dazu.

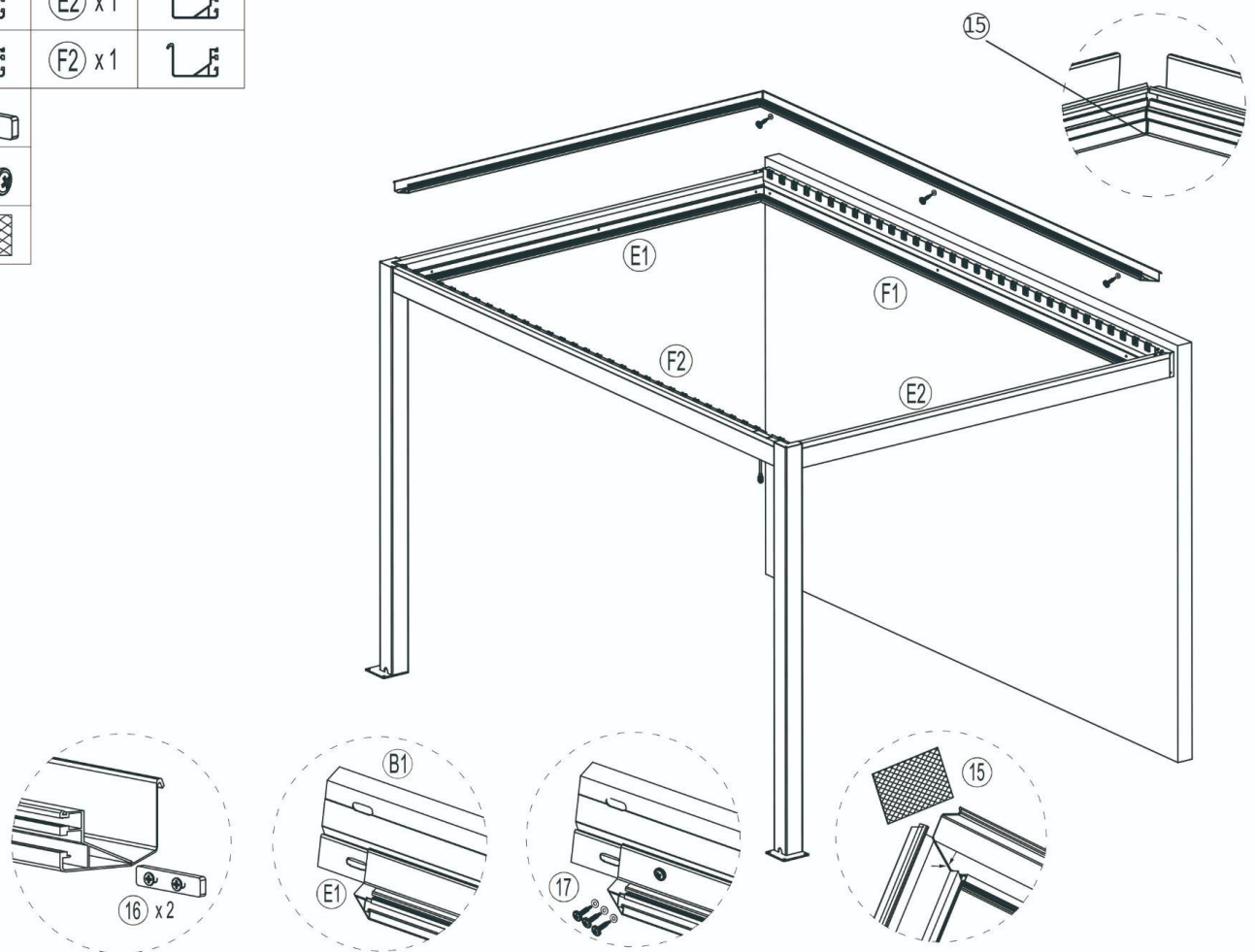

①x1		②x1	
③x1		④x1	
⑤x8			
⑥x12			
⑦x4			



Schritt 8:

Installieren sie die Steuerlamellen (H)x1 in der zweiten Reihe.

Danach installieren sie die restlichen Lamellen der Reihe nach.



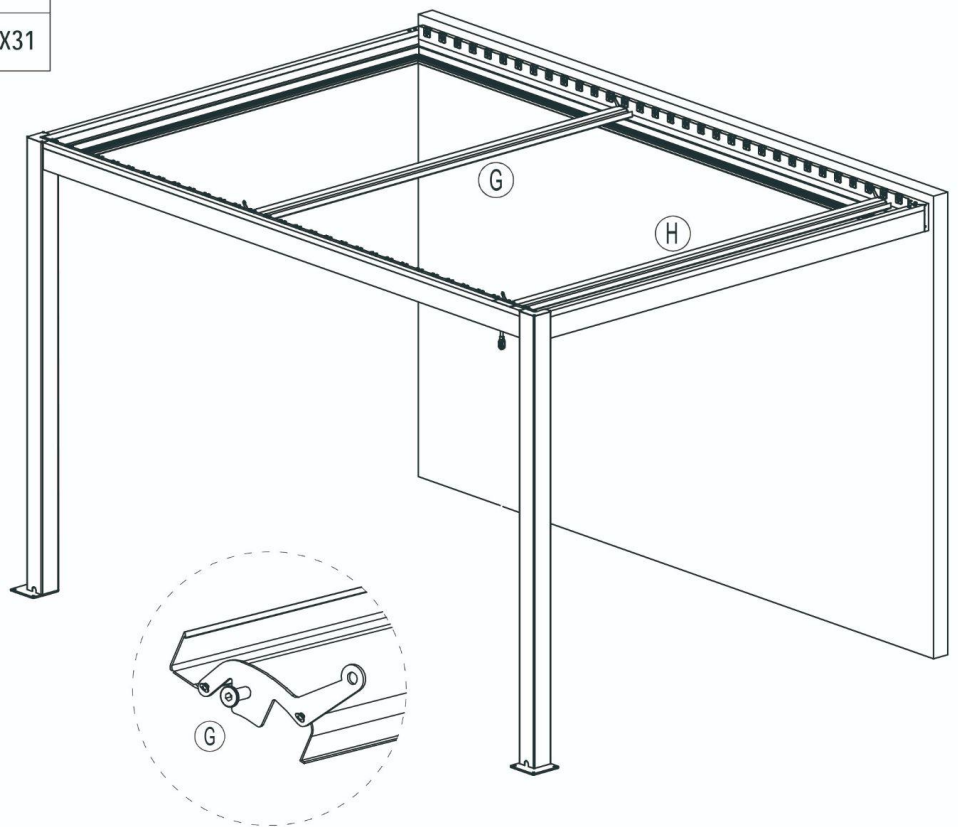
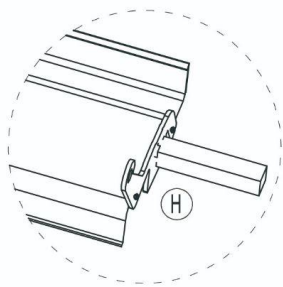

300X300		(H) X1	(G) X22
300X400		(H) X1	(G) X31
400X400		(H) X1	(G) X31



Schritt 9:

Verbinden sie die Lamellen und die Lenkschienen (J) mit (5) (6) (7) wie unten abgebildet.

Fahren sie fort indem sie alle Schrauben festziehen.

				
300X300	(5) X46	(6) X46	(7) X46	(J) X2
300X400	(5) X64	(6) X64	(7) X64	(J) X2
400X400	(5) X64	(6) X64	(7) X64	(J) X2

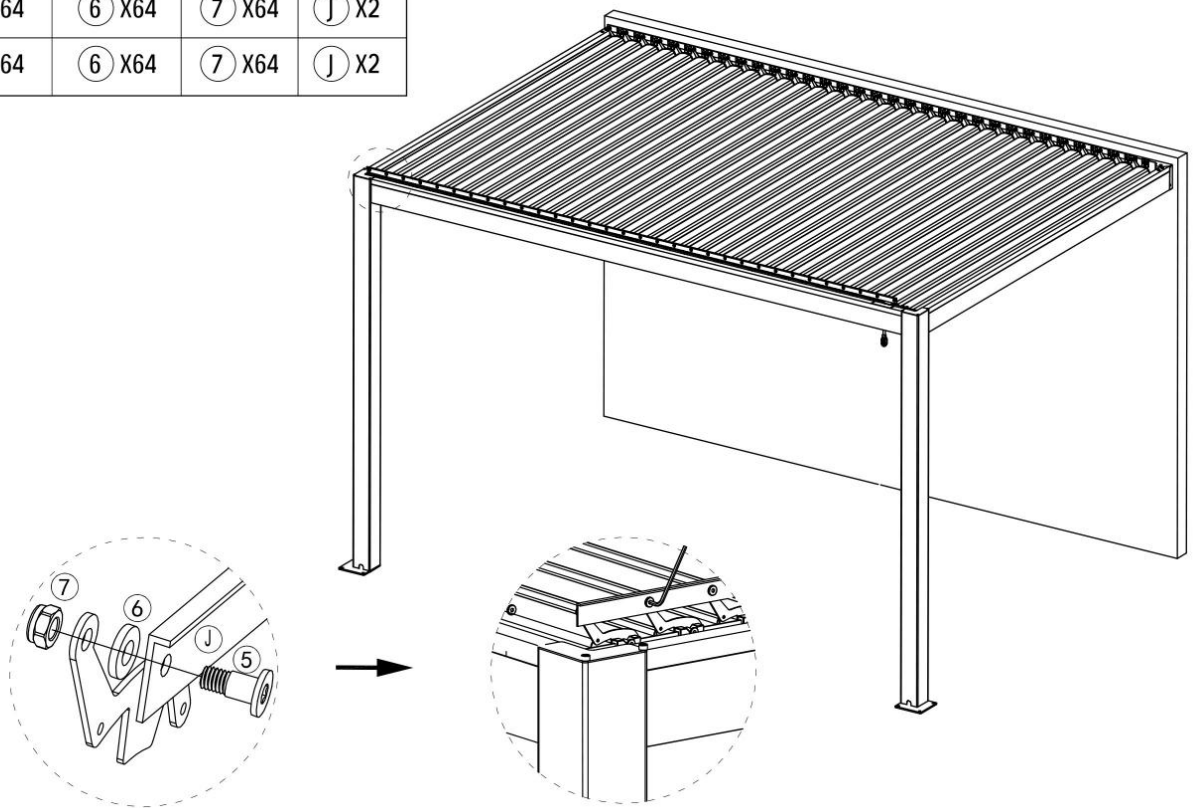

Schritt 10:

Nun können sie die Pergola am Boden befestigen. Geeignete Befestigungsmittel können sie im Baumarkt erwerben. Achten sie darauf nicht durch Membranen usw. zu schrauben.

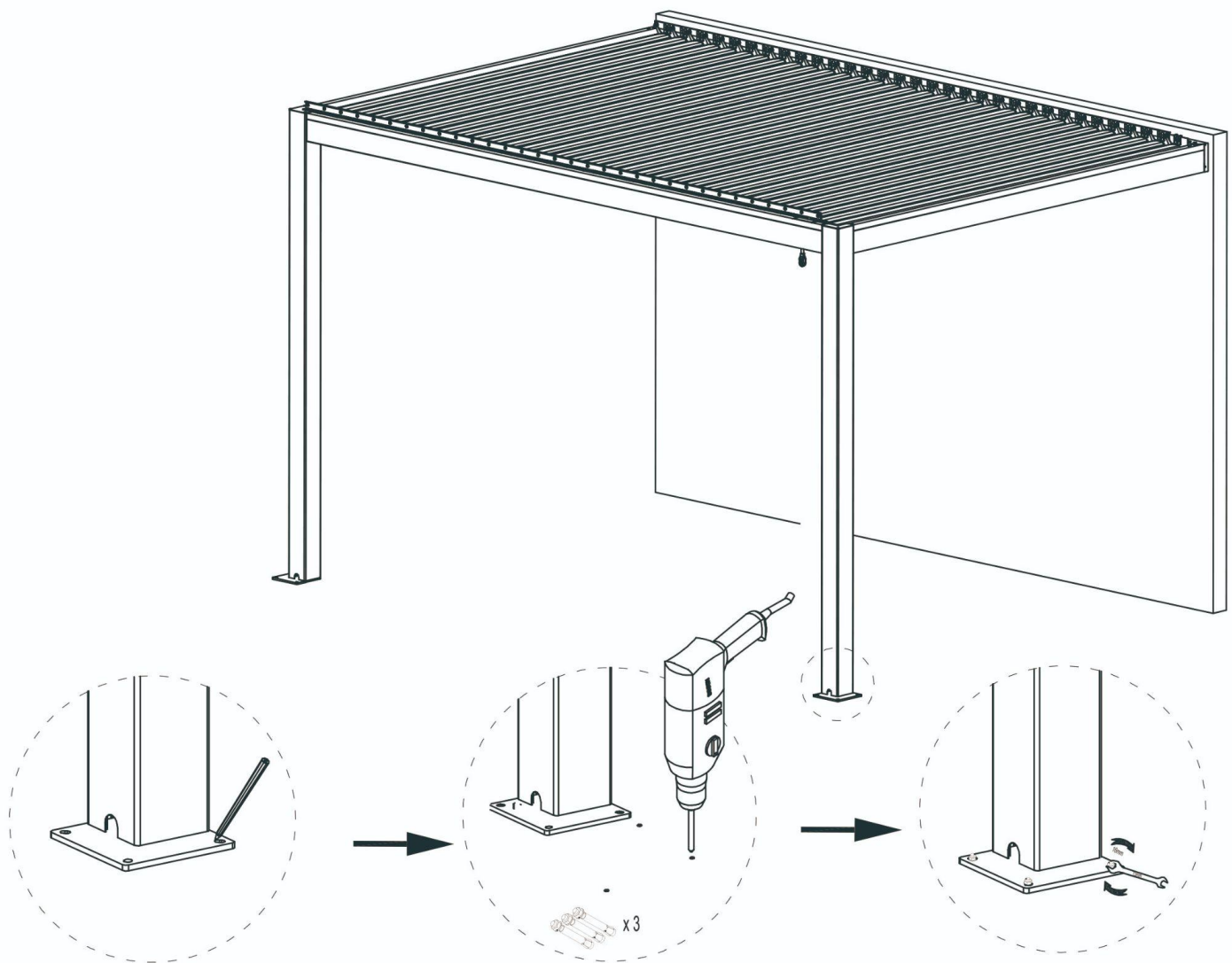

Schritt 11:

Montieren sie die Windschutzplatten ⑬ ⑭ mit den Schrauben an den Trägern wie unten abgebildet:

⑬ x2		
⑭ x2		

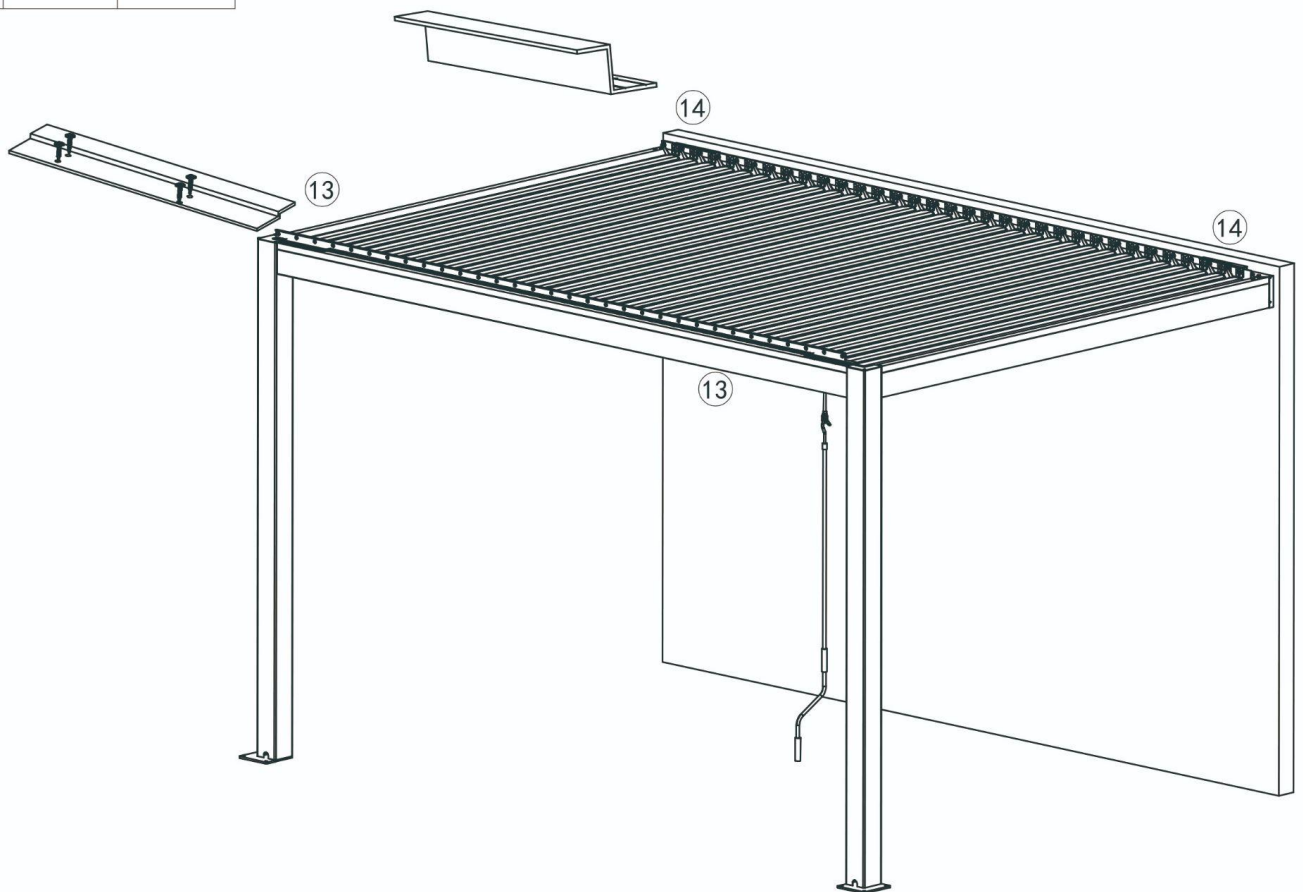

Sikkerhetsinstruksjoner / Security Instructions / Sicherheitshinweise:

For alles sikkerhet er det viktig å følge instruksjonene nedenfor.

Ikke monter denne pergolaen selv, men kontakt en fagkyndig for hjelp dersom:

- du er usikker på om pergolaen kan monteres på stedet du har valgt for montasje.
- du forstår ikke bruksanvisningen eller deler av den.
- du ikke har de nødvendige verktøyene tilgjengelig.

Ikke monter pergolaen når du finner ødelagte deler eller deler som mangler. Skulle dette være tilfelle - kontakt oss omgående på ***kundeservice@pergolux.no***.

////

For the safety of all it is very important to follow the instructions below

Do not assemble this pergola yourself, but contact a professional for help if:

- you are unsure if the pergola can be assembled in the place you have chosen for installation.
- you do not understand the instruction manual or parts of it.
- you do not have the necessary tools available.

Do not install the pergola when you find damaged parts or parts that are missing. Contact us immediately at customerservice@pergolux.com if this is the case.

////

Für ihre Sicherheit und die von anderen, ist es sehr wichtig die folgenden Anweisungen zu befolgen.

Montieren Sie die Pergola nicht selbst, sondern wenden sich an einen Fachmann wenn:

- Sie sich nicht sicher sind, ob die Pergola an dem von ihnen gewählten Standort montiert werden kann.
- Sie die Montageanleitung, oder Teile davon, nicht verstehen.
- Sie nicht die notwendigen Werkzeuge zur Verfügung haben.

Montieren Sie die Pergola nicht, wenn Sie beschädigte oder fehlende Teile bemerken. Sollte dies der Fall sein, kontaktieren sie uns umgehend unter

kundenservice@pergolux.de

Avslutende ord fra Pergolux-teamet

Gratulerer med ferdig montert pergola! Nå har du forbrent noen kalorier og fortjener virkelig å slappe av under Pergolux-pergolaen. Vi håper du var fornøyd med bestillingsprosessen, leveringen, monteringen og selve produktet. Vi ønsker å kontinuerlig forbedre oss og er veldig interessert i dine tilbakemeldinger på nettsiden vår.

Vi ønsker deg mange flotte øyeblikk under din nye Pergolux pergola.

Varme og solfylte hilsener, Pergolux-teamet ditt

Schlussworte vom Team Pergolux

Herzlichen Glückwunsch zur komplett montierten Pergola! Jetzt haben Sie einige Kalorien verbrannt und haben es verdient, unter der Pergolux Pergola richtig zu entspannen. Wir hoffen, Sie waren mit dem Bestellvorgang, der Anlieferung, der Montage und dem Produkt richtig zufrieden. Wir möchten uns laufend verbessern und sind sehr an einer Rückmeldung über unsere Webseite interessiert.

Wir wünschen Ihnen viele schöne Momente unter Ihrer neuen Pergolux Pergola.

Warme und sonnige Grüße, Ihr Pergolux Team

Closing remarks from the Pergolux team

Congratulations on the assembled pergola! You have now burned some calories and really deserve to relax under the Pergolux pergola. We hope that you were satisfied with the ordering process, the delivery, the assembly and the product itself. We want to continuously improve and are very interested in your feedback.

We wish you many wonderful moments under your new Pergolux pergola.

Warm and sunny greetings,

Your Pergolux team

PS: soon you will find other products in our online store that are compatible with your Pergolux pergola - such as sliding glass walls, heat lamps, glass ceilings, fireplaces, etc.

Johannes



Erich

Henrik

Marielle

Dani

Henry



Robin

Sofie

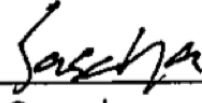

Lucas

Alexander

Christian

Sascha

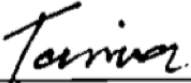
Elin

Tamina