



**ULTRA PRO
SERIES™**

Extra Heavy Duty STEP STANDS



Heavy duty broad top and 6" steps. Deep treads provide slip resistance.

Locking spreader permanently stays open.

Extra large feet for use on gratings

For Extra Heavy Duty/Professional Use

300 Lbs. Load Capacity
TYPE IA DUTY RATING



Fiberglass models have electrically Non-Conductive rails

MODELS AVAILABLE



2' ALUMINUM
MODEL SSA02



3' ALUMINUM
MODEL SSA03



2' FIBERGLASS
MODEL SSF02



3' FIBERGLASS
MODEL SSF03



2' and 3' Step Stands

Load Capacity 300 lbs.

Extra Heavy Duty/Professional Use
Type IA Duty Rating

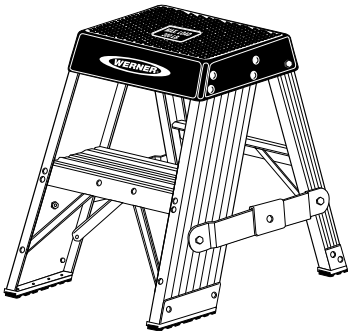

2' ALUMINUM
MODEL SSA02

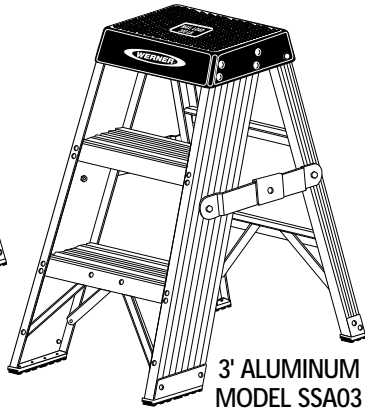

3' ALUMINUM
MODEL SSA03

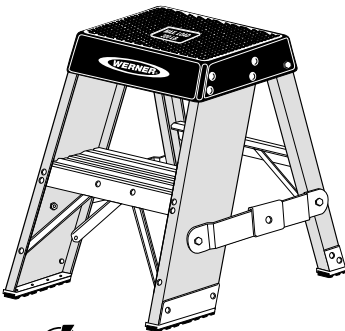

2' FIBERGLASS
MODEL SSF02



3' FIBERGLASS
MODEL SSF03

- Heavy duty broad steps and top. Deep treads provide slip resistance.
- Extra large feet for use on gratings.
- Permanently open, very durable & stable.
- Rust resistant, rugged aluminum construction.
- Fiberglass models have electrically non-conductive rails.
- Made in USA
- Meets ANSI standards
- Meets OSHA standards



DIMENSIONS

Top: 9" x 14"
 Front Rails: 6" wide
 Flange: 1-1/8" wide
 Steps: 6"
 Rear Rails: 1-7/8" wide
 Flange: 1-3/16" wide

SPECIFICATIONS

Model No.	Size	Maximum Standing Height	Approx. Width	Approx. Spread	Approx. CU. FT. Per Unit	Approx. Ship Wt. Lbs.	UPC Codes
SSA02	2'	20"	17"	21"	2.6	16.0	0 51751 6
SSA03	3'	30"	18-3/4"	27-1/2"	4.0	20.5	04158 3
SSF02	2'	20"	17"	21"	2.6	15.0	04159 0
SSF03	3'	30"	18-3/4"	27-1/2"	4.0	19.5	04160 6

All Werner step stands ship folded for more compact storage.

