

M3 Socket Head Cap Machine Screws (SHCS)

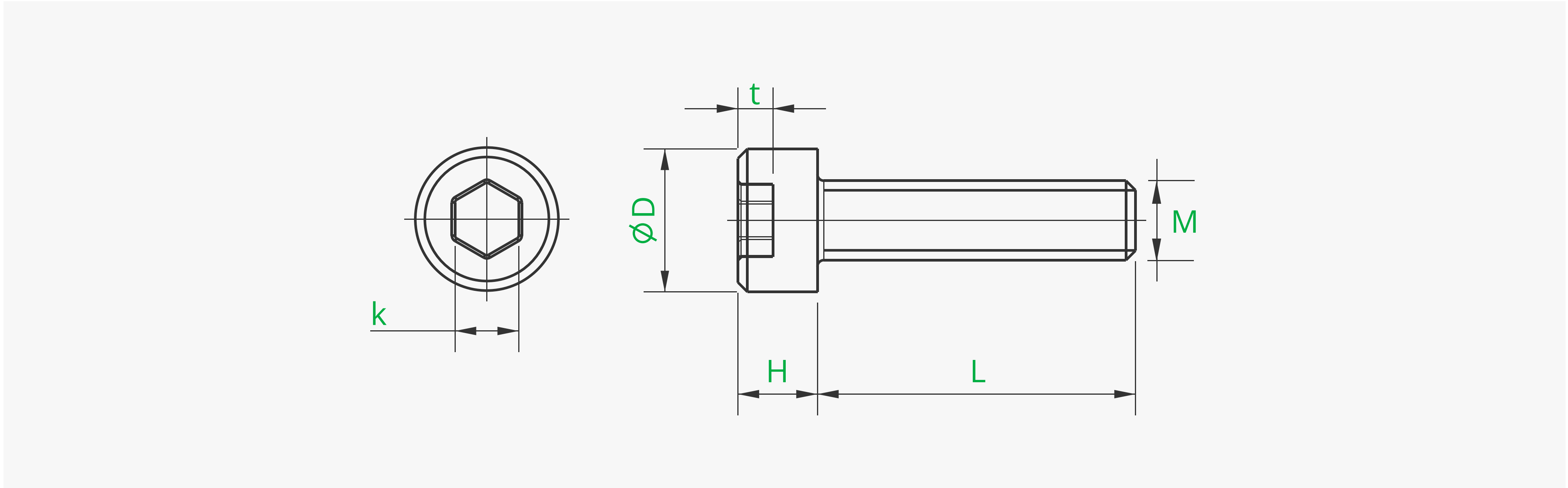

Product ID	L (mm) Bolt Length	D (mm) Head Diameter	H (mm) Head Thickness	k (mm) Hexagon Across Flats	t (mm) Groove Depth	Screwdriver Bit Size
AA158	5	5.4	2.8	2.5	1.3	H2.5
AA036	6	5.4	2.8	2.5	1.3	H2.5
AA037	8	5.4	2.8	2.5	1.3	H2.5
AA159	10	5.4	2.8	2.5	1.3	H2.5
AA038	12	5.4	2.8	2.5	1.3	H2.5
AA160	14	5.4	2.8	2.5	1.3	H2.5
AA039	16	5.4	2.8	2.5	1.3	H2.5
AA161	18	5.4	2.8	2.5	1.3	H2.5
AA040	20	5.4	2.8	2.5	1.3	H2.5
AA041	25	5.4	2.8	2.5	1.3	H2.5
AA042	30	5.4	2.8	2.5	1.3	H2.5

*Compliant with the requirements of GB/T 70.1-2008 standard [Equivalent standards: ISO 4762, ASME/ANSI B 18.3.1M - 1986 (R1993), DIN EN ISO 12474]

Basic Information

Surface Treatment	No	Material	Carbon steel
Mounting Hole Shape	Hex socket	Thread Ridge Type	Metric coarse
Screw Type	Complete thread	Color	Silver

Product Feature

- Carbon Steel Socket Head Cap Machine Screws (SHCS)
- Nominal thread: M1.6~M5
- Strength grade: 4.8
- Full thread series
- Type of thread: Metric coarse thread

M3 圆柱头机牙螺丝

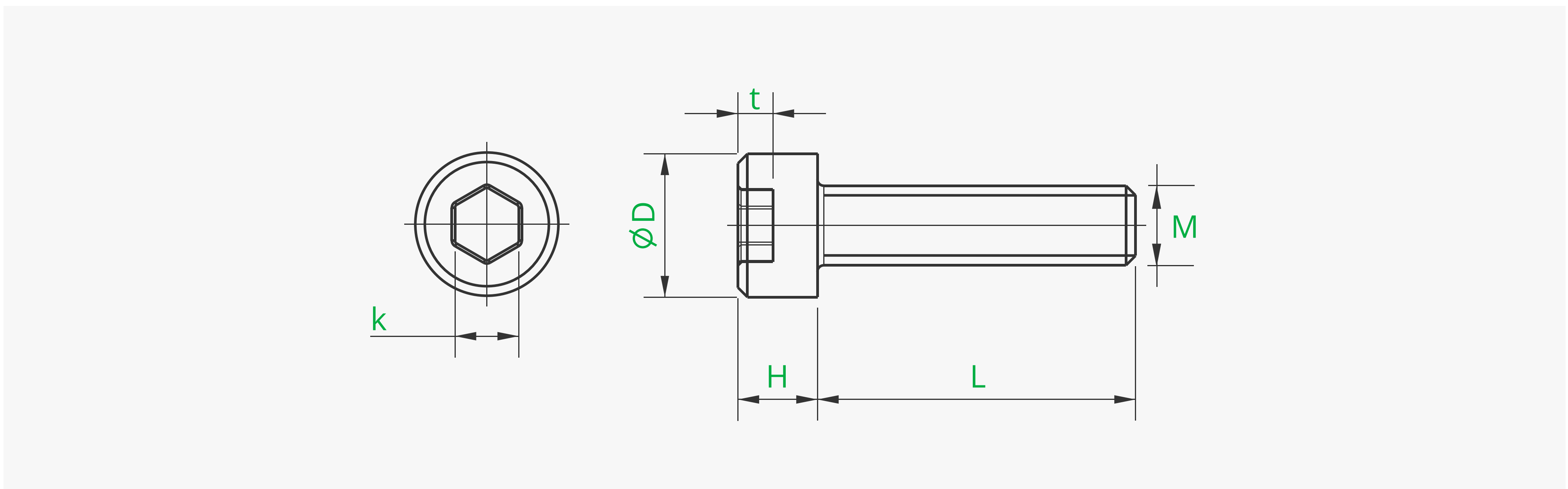

产品ID	螺栓长度L (mm)	头部直径D (mm)	头部厚度H (mm)	六角对边距k (mm)	槽深t (mm)	适配批头
AA158	5	5.4	2.8	2.5	1.3	H2.5
AA036	6	5.4	2.8	2.5	1.3	H2.5
AA037	8	5.4	2.8	2.5	1.3	H2.5
AA159	10	5.4	2.8	2.5	1.3	H2.5
AA038	12	5.4	2.8	2.5	1.3	H2.5
AA160	14	5.4	2.8	2.5	1.3	H2.5
AA039	16	5.4	2.8	2.5	1.3	H2.5
AA161	18	5.4	2.8	2.5	1.3	H2.5
AA040	20	5.4	2.8	2.5	1.3	H2.5
AA041	25	5.4	2.8	2.5	1.3	H2.5
AA042	30	5.4	2.8	2.5	1.3	H2.5

*符合GB/T 70.1-2008标准要求 [等效标准: ISO 4762、ASME/ANSI B 18.3.1M - 1986 (R1993)、DIN EN ISO 12474]

基本信息

表面处理	无	材质	碳钢
批头种类	内六角	螺纹牙形	公制粗牙
牙长	全螺纹型	表面颜色	银色

产品特点

- 碳钢半圆头机牙螺丝
- 螺纹公称: M2~M4
- 强度等级: 4.8
- 全牙系列
- 螺纹牙形种类: 公制粗牙