

M1.6 Socket Head Cap Machine Screws (SHCS)

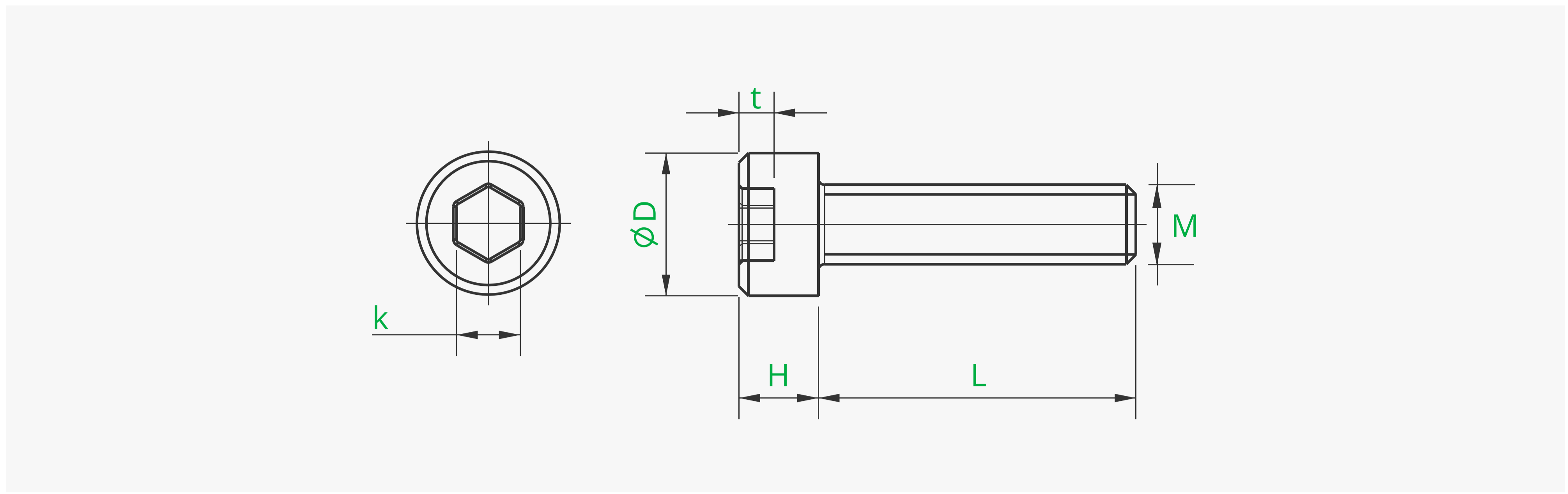

Product ID	L (mm) Bolt Length	D (mm) Head Diameter	H (mm) Head Thickness	k (mm) Hexagon Across Flats	t (mm) Groove Depth	Screwdriver Bit Size
AA021	4	3	1.1	1.5	0.8	H1.5

*Compliant with the requirements of GB/T 70.1-2008 standard [Equivalent standards: ISO 4762, ASME/ANSI B 18.3.1M - 1986 (R1993), DIN EN ISO 12474]

Basic Information

Surface Treatment	No	Material	Carbon steel
Mounting Hole Shape	Hex socket	Thread Ridge Type	Metric coarse
Screw Type	Complete thread	Color	Silver

Product Feature

- Carbon Steel Socket Head Cap Machine Screws (SHCS)
- Nominal thread: M1.6-M5
- Strength grade: 4.8
- Full thread series
- Type of thread: Metric coarse thread

M1.6 圆柱头机牙螺丝

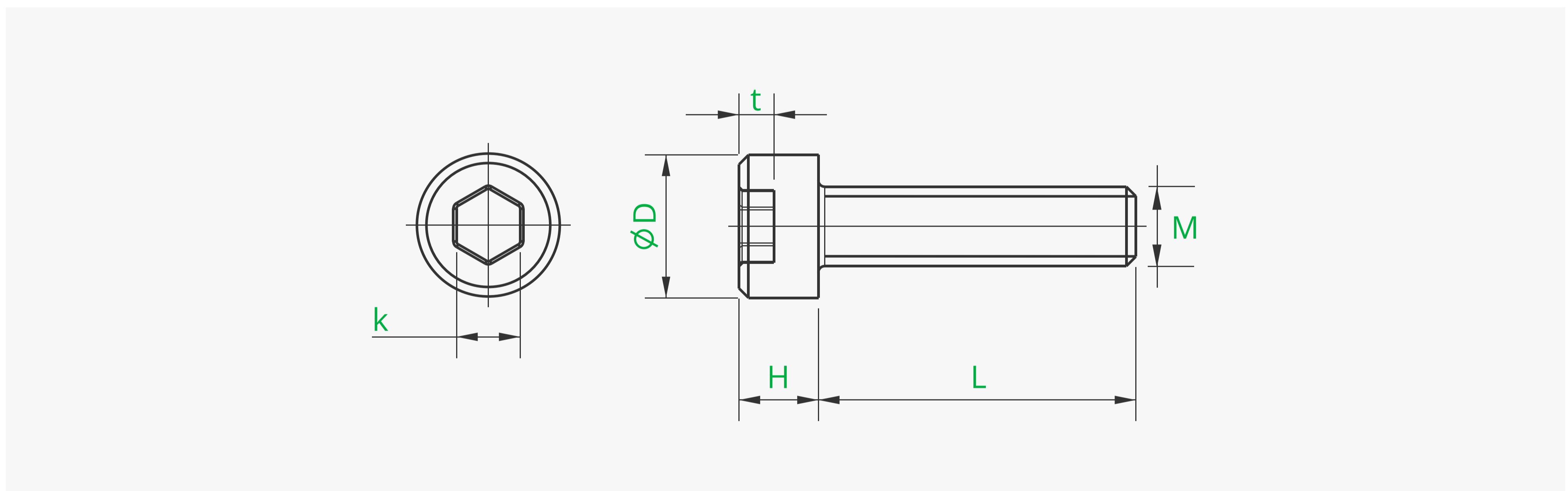

产品ID	螺栓长度L (mm)	头部直径D (mm)	头部厚度H (mm)	六角对边距k (mm)	槽深t (mm)	适配批头
AA021	4	3	1.1	1.5	0.8	H1.5

*符合GB/T 70.1-2008标准要求 [等效标准: ISO 4762、ASME/ANSI B 18.3.1M - 1986 (R1993)、DIN EN ISO 12474]

基本信息

表面处理	无	材质	碳钢
批头种类	内六角	螺纹牙形	公制粗牙
牙长	全螺纹型	表面颜色	银色

产品特点

- 碳钢半圆头机牙螺丝
- 螺纹公称: M2-M4
- 强度等级: 4.8
- 全牙系列
- 螺纹牙形种类: 公制粗牙