

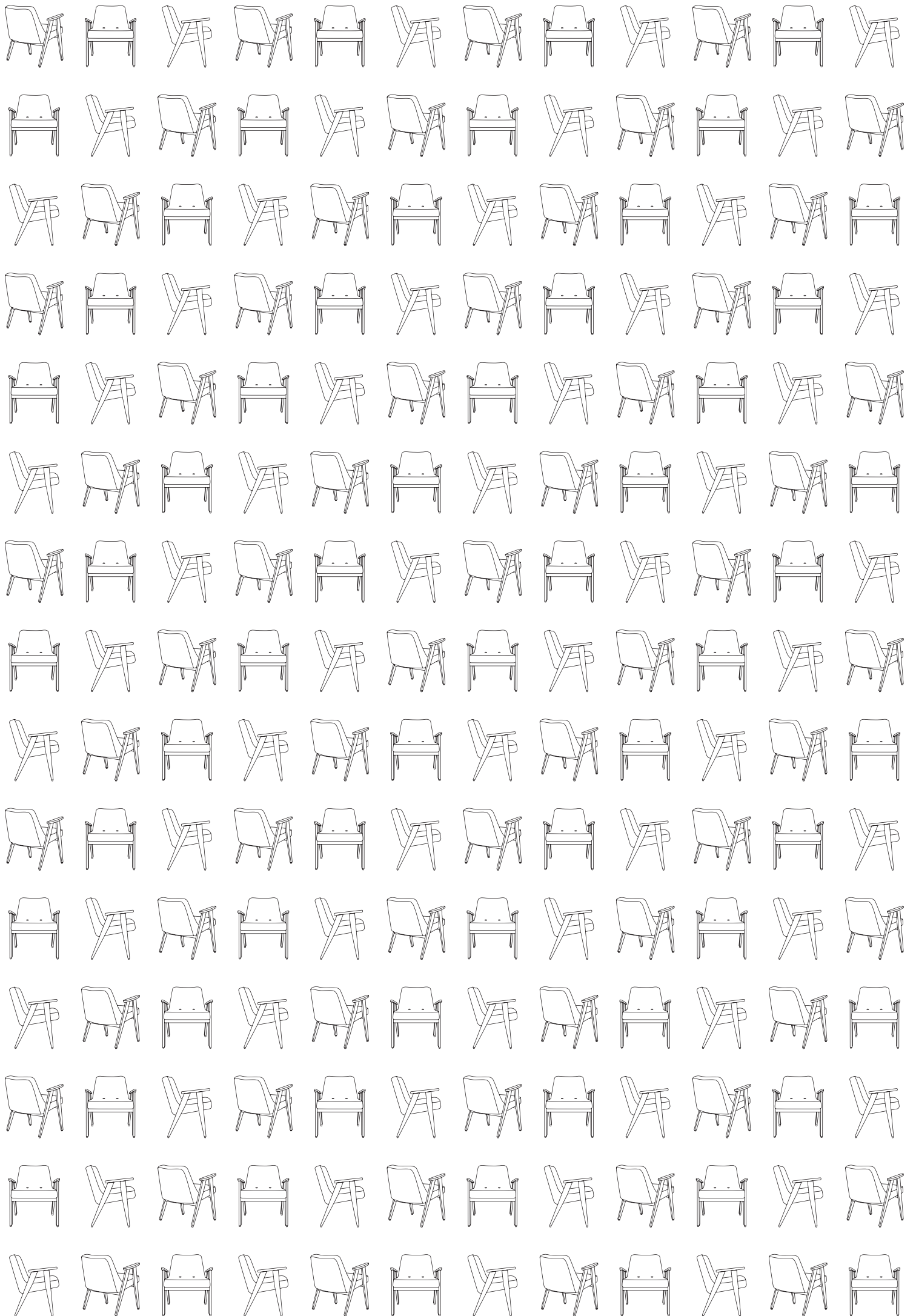

EDITOR & CREATOR
of MID-CENTURY ICONS



PRODUCT CATALOG 2023



*Discover our Story
behind the Authentic
Polish Design Icons*

PRODUCT CATALOG 2023



366 Armchair by Józef Chierowski – *the Story behind the Polish Design Icon*

Our name comes from our flagship model – *the 366 Armchair*. It was the most popular piece of *Polish Mid-Century* furniture.

This was partly a matter of luck: in the early 1960s, one of the biggest factories in Poland was destroyed by fire, creating sudden need for simple furniture that could be assembled quickly.

The 366 Armchair was manufactured for over 20 years, with more than million copies sold throughout the Eastern Bloc. Despite such success, this masterpiece never had the chance to be noticed outside of the Soviet sphere of influence.

For years, Józef Chierowski divided his time between working as an interior architect, a designer for the Lower Silesian Furniture Factory in Świebodzice and chairing the Department of Industrial Design at *the National Academy of Arts* in Wrocław, Poland.

He worked on multiple popular furniture pieces, including *the VAR Chair*, yet his most *significant accomplishment* was the design for *the 366 Armchair*, which became a true Icon of *Polish Mid-Century Design*, as well as one of the *most beloved furniture pieces* of the 1950s and 1960s.

Content

CHAIRS	6	FOOTRESTS	78
200-190 CHAIR	6	FOX FOOTREST	78
200-190 CHAIR STACKABLE	8		
200-190 CHAIR MIX	10	BENCHES	80
200-190 CHAIR TIMBER	12	200-190 BENCH	80
200-125 VAR CHAIR	14	FOX BENCH 90	82
		FOX BENCH 125	83
BAR STOOLS	16		
200-190 BAR STOOL S65	16	COFFEE TABLES	84
200-190 BAR STOOL M75	18	FOX ROUND COFFEE TABLE S & M	84
200-190 BAR SOOL MIX S65	20	FOX ROUND COFFEE TABLE L28	86
200-190 BAR STOOL MIX M75	22	FOX ROUND COFFEE TABLE L32	88
200-190 BAR STOOL TIMBER S65	24	FOX ROUND SIDE COFFEE TABLE H	90
200-190 BAR STOOL TIMBER M75	26	FOX SQUARE COFFEE TABLE S37	92
200-190 BAR STOOL BASIC S65	28	FOX SQUARE COFFEE TABLE S55	94
200-190 BAR STOOL BASIC M75	29	FOX RECTANGULAR COFFEE TABLE M37	96
200-190 BAR STOOL BASIC TIMBER S65	30	FOX RECTANGULAR COFFEE TABLE M55	98
200-190 BAR STOOL BASIC TIMBER M75	31	FOX TECKEL COFFEE TABLE	100
		FOX MARBLE ROUND COFFEE TABLE	102
ARMCHAIRS	32	FOX MARBLE LONG COFFEE TABLE	104
366 ARMCHAIR	32	366 TRIANGLE COFFEE TABLE S	106
366 METAL ARMCHAIR BLACK MATT	34	366 TRIANGLE COFFEE TABLE M	108
366 METAL ARMCHAIR BRASS MATT	36		
366 METAL CLUB BLACK MATT	38	DINING TABLES	110
366 JUNIOR ARMCHAIR	40	ELLIPSE & ROUND	110
BUNNY ARMCHAIR	42		
FOX LOUNGE CHAIR	44	DESKS	112
FOX CLUB LOUNGE CHAIR	46	MINIMALIST DESK S60	112
FOX METAL LOUNGE CHAIR	48	MINIMALIST DESK M80	114
STEFAN LOUNGE CHAIR	50		
		SIDEBOARDS	116
ROCKING CHAIRS	52	1050 PETITE SIDEBOARD	116
366 ROCKING CHAIR	52	1050 PETITE SIDEBOARD WITH GLASS	118
366 JUNIOR ROCKING CHAIR	53	1050 LONG SIDEBOARD	120
FOX ROCKING CHAIR	54	1050 HIGHBOARD	122
SOFAS	56	CUSHIONS	124
366 2-SEATER	56	CURTAINS	130
366 METAL 2-SEATER	58		
BUNNY 2-SEATER	60	FINISHES	132
FOX 2-SEATER	62	FABRICS	132
FOX SOFA	64	WOOD	147
366 3-SEATER	65	METAL	148
FOX CLUB SOFA	66	MARBLE	149
FOX LONG SOFA	68		
FOX 3-SEATER	70	FURNITURE SERIES	151
STEFAN 2-SEATER	72		
STEFAN SOFA	74	CONTACTS	158
FOX METAL 2-SEATER	76		
FOX METAL SOFA	77		

Chairs

200-190 CHAIR

Story behind:

The 200-190 Chair, designed in the 1960s. It has become the undisputed Icon of Polish Design. The light form of this upholstered chair and the use of ash with brass details give it a nobility and timelessness that still amazes. The 200-190 Chair is also available in mix, timber and stackable version.

Original design: 1960s

Reedition: 2020 by 366 Concept

Legs: solid ash wood with brass finishing

Internal structure: plywood

Seat: high resilience foam

Contract: norm passed EN 16139

COM: 1 pc = 1,5 x 1,4 m / 2+ pcs = 1,5 x 1,4 m

COL: 1 pc = 0,8 m2, from 4 pcs

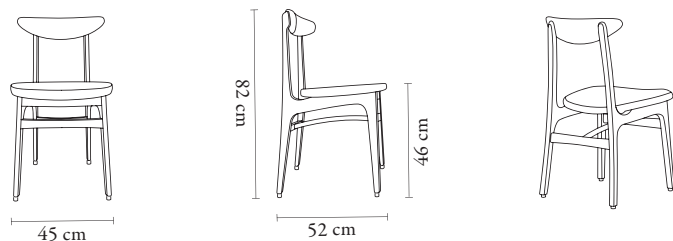

Width: 45 cm

Height: 82 cm

Depth: 52 cm

Seat height: 46 cm

Packaging dimensions: 86 x 49 x 55 cm

Delivery: fully assembled furniture

Net weight: 6,4 kg

Gross weight: 8 kg

100% designed and manufactured in Poland



Coco Coll. - Creme / Ash 03



Boucle Coll. - Beige / Ash 03



Chairs

200-190 CHAIR STACKABLE

Story behind:

The stackable version of the 200-190 Chair model is the next stage in the development of the most popular furniture piece in our assortment. A classic from the 1960s in a stackable version has become a popular solution for customers who want to combine unique design with practical aspects of furniture.

Original design: 1960s

Reedition: 2022 by Maciek Cypryk, stackable version based on the 200-190 Chair

Stacking maximum: 3-4 chairs

Legs: solid ash wood with brass finishing

Internal structure: plywood

Seat: high resilience foam

Contract: norm passed EN 16139

COM: 1 pc = 1,5 x 1,4 m / 2+ pcs = 1,5 x 1,4 m

COL: 1 pc = 0,8 m², from 4 pcs

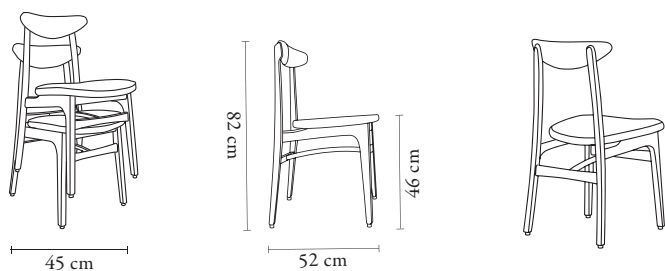

Width: 45 cm

Height: 82 cm

Depth: 52 cm

Seat height: 46 cm

Packaging dimensions: 86 x 49 x 55 cm

Delivery: fully assembled furniture

Net weight: 6,4 kg

Gross weight: 8 kg

100% designed and manufactured in Poland



Coco Coll. - Beige / Ash 03



Coco Coll. - Beige / Ash 03



Chairs

200-190 CHAIR MIX

Story behind:

The 200-190 Chair, designed in the 1960s. It has become the undisputed Icon of Polish Design. The light form of this upholstered chair and the use of ash with brass details give it a nobility and timelessness that still amazes.

Original design: 1960s

Reedition: 2021 by 366 Concept

Legs: solid ash wood with brass finishing

Internal structure: plywood

Seat: high resilience foam

Contract: norm passed EN 16139

COM: 1 pc = 1,5 x 1,4 m / 2+ pcs = 1,5 x 1,4 m

COL: 1 pc = 0,5 m2, from 4 pcs

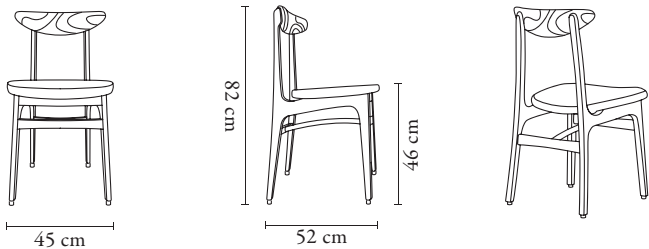

Width: 45 cm

Height: 82 cm

Depth: 52 cm

Seat height: 46 cm

Packaging dimensions: 86 x 49 x 55 cm

Delivery: fully assembled furniture

Net weight: 6,4 kg

Gross weight: 8 kg

100% designed and manufactured in Poland



Natural Leather Coll. - Cognac / Ash 03



Natural Leather Coll. - Cognac / Ash 03



Chairs

200-190 CHAIR TIMBER

Story behind:

The 200-190 Chair, designed in the 1960s. It has become the undisputed Icon of Polish Design. The light form of this wooden chair and the use of ash with brass details give it a nobility and timelessness that still amazes.

Original design: 1960s

Reedition: 2021 by 366 Concept

Legs: solid ash wood with brass finishing

Seat and backrest: veneered plywood

Contract: norm passed EN 16139

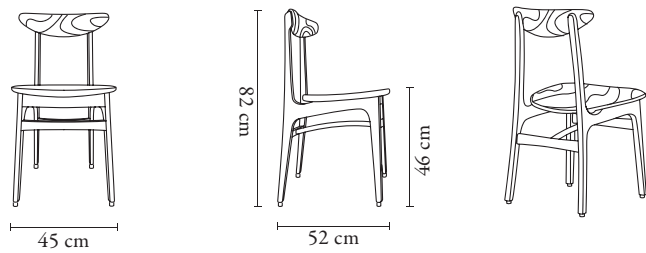

Width: 45 cm

Height: 82 cm

Depth: 52 cm

Seat height: 46 cm

Packaging dimensions: 86 x 49 x 55 cm

Delivery: fully assembled furniture

Net weight: 6,4 kg

Gross weight: 8 kg

100% designed and manufactured in Poland



Ash 04



Ash 04



Chairs

200-125 VAR CHAIR

Story behind:

An Icon of Polish Design – the 200-125 VAR Chair – designed by Józef Chierowski in the early 1970s. It was created to comfortably pursue the designer's passion – long bridge games. It is a great example of classic design with a sublime and economical form.

Original design: Józef Chierowski, 1970s

Reedition: 2021 by 366 Concept

Legs: solid ash wood with brass finishing

Internal structure: solid beech wood

Seat: zig zag springs, high resilience foam

COM: 1 pc = 1,3 x 1,4 m / 2+ pcs = 1,3 x 1,4 m

COL: 1 pc = 0,8 m2, from 4 pcs

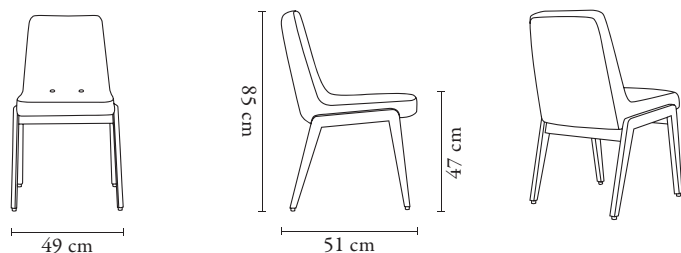

Width: 49 cm

Height: 85 cm

Depth: 51 cm

Seat height: 47 cm

Packaging dimensions: 88 x 55 x 54 cm

Delivery: fully assembled furniture

Net weight: 8,8 kg

Gross weight: 11 kg

100% designed and manufactured in Poland



Boucle Coll. - Sierra / Ash 03



Boucle Coll. - Mustard / Ash 03



Bar stools

200-190 BAR STOOL S65

Story behind:

A bar version of the Iconic 200-190 Chair designed in the 1960s. It has become the undisputed Icon of Polish Design. The light form of this upholstered bar stool and the use of ash with brass details give it a nobility and timelessness that still amazes. The 200-190 Bar Stool is available in 2 sizes - S65 and M75.

Design: 2020 by Agata Górką, based on the 200-190 Chair from 1960s

Legs: solid ash wood with brass finishing

Internal structure: plywood

Seat: high resilience foam

Contract: norm passed EN 16139

COM: 1 pc = 1,5 x 1,4 m / 2+ pcs = 1,5 x 1,4 m

COL: 1 pc = 0,8 m2, from 4 pcs

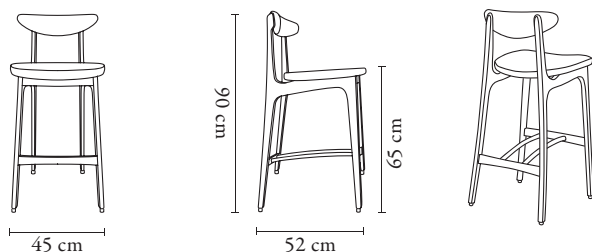

Width: 45 cm

Height: 90 cm

Depth: 52 cm

Seat height: 65 cm

Packaging dimensions: 93 x 48 x 55 cm

Delivery: fully assembled furniture

Net weight: 7,2 kg

Gross weight: 9 kg

100% designed and manufactured in Poland



Velvet Coll. - Red Brick / Ash 03



Shine Velvet Coll. - Mustard / Ash 03



Bar stools

200-190 BAR STOOL M75

Story behind:

A bar version of the Iconic 200-190 Chair designed in the 1960s. It has become the undisputed Icon of Polish Design. The light form of this upholstered bar stool and the use of ash with brass details give it a nobility and timelessness that still amazes. The 200-190 Bar Stool is available in 2 sizes - S65 and M75.

Design: 2020 by Agata Górka, based on the 200-190 Chair from 1960s

Legs: solid ash wood with brass finishing

Internal structure: plywood

Seat: high resilience foam

Contract: norm passed EN 16139

COM: 1 pc = 1,5 x 1,4 m / 2+ pcs = 1,5 x 1,4 m

COL: 1 pc = 0,8 m2, from 4 pcs

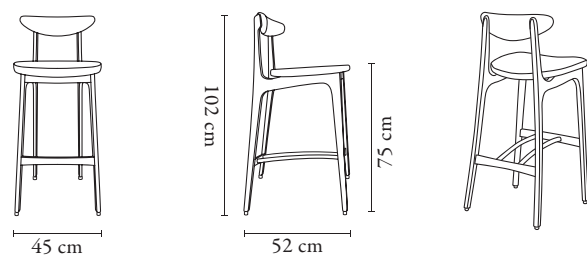

Width: 45 cm

Height: 102 cm

Depth: 52 cm

Seat height: 75 cm

Packaging dimensions: 104 x 49 x 55 cm

Delivery: fully assembled furniture

Net weight: 7,2 kg

Gross weight: 9 kg

100% designed and manufactured in Poland



Coco Coll. - Creme / Ash 03



Coco Coll. - Creme / Ash 03



Bar stools

200-190 BAR STOOL MIX S65

Story behind:

A bar version of the Iconic 200-190 Chair designed in the 1960s. It has become the undisputed Icon of Polish Design. The light form of this upholstered bar stool and the use of ash with brass details give it a nobility and timelessness that still amazes. The 200-190 Bar Stool Mix is available in 2 sizes - S65 and M75.

Design: 2021 by Agata Górká, based on the 200-190 Chair from 1960s

Legs: solid ash wood with brass finishing

Internal structure: plywood

Seat: high resilience foam

Contract: norm passed EN 16139

COM: 1 pc = 1,5 x 1,4 m / 2+ pcs = 1,5 x 1,4 m

COL: 1 pc = 0,5 m², from 4 pcs

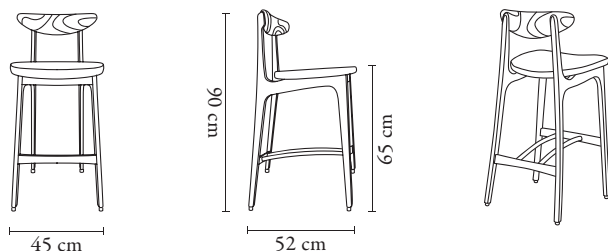

Width: 45 cm

Height: 90 cm

Depth: 52 cm

Seat height: 65 cm

Packaging dimensions: 93 x 48 x 55 cm

Delivery: fully assembled furniture

Net weight: 7,2 kg

Gross weight: 9 kg

100% designed and manufactured in Poland



Boucle Coll. - Sierra / Ash 03



Boucle Coll. - Sierra / Ash 03



Bar stools

200-190 BAR STOOL MIX M75

Story behind:

A bar version of the Iconic 200-190 Chair designed in the 1960s. It has become the undisputed Icon of Polish Design. The light form of this upholstered bar stool and the use of ash with brass details give it a nobility and timelessness that still amazes. The 200-190 Bar Stool Mix is available in 2 sizes - S65 and M75.

Design: 2021 by Agata Górka, based on the 200-190 Chair from 1960s

Legs: solid ash wood with brass finishing

Internal structure: plywood

Seat: high resilience foam

Contract: norm passed EN 16139

COM: 1 pc = 1,5 x 1,4 m / 2+ pcs = 1,5 x 1,4 m

COL: 1 pc = 0,5 m2, from 4 pcs

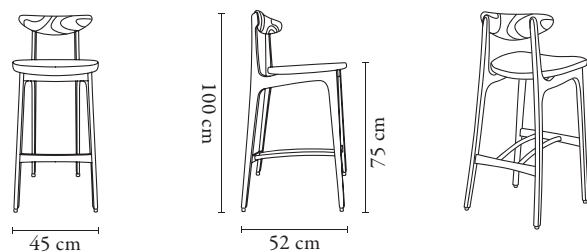

Width: 45 cm

Height: 100 cm

Depth: 52 cm

Seat height: 75 cm

Packaging dimensions: 104 x 49 x 55 cm

Delivery: fully assembled furniture

Net weight: 7,2 kg

Gross weight: 9 kg

100% designed and manufactured in Poland



Shine Velvet Coll. - Mustard / Ash 03



Shine Velvet Coll. - Mustard / Ash 03



Bar stools

200-190 BAR STOOL TIMBER S65

Story behind:

A bar version of the Iconic 200-190 Chair designed in the 1960s. It has become the undisputed Icon of Polish Design. The light form of this bar stool and the use of ash with brass details give it a nobility and timelessness that still amazes. The 200-190 Bar Stool Timber is available in 2 sizes - S65 and M75.

Design: 2021 by Agata Górka, based on the 200-190 Chair from 1960s

Legs: solid ash wood with brass finishing

Seat and backrest: plywood

Contract: norm passed EN 16139

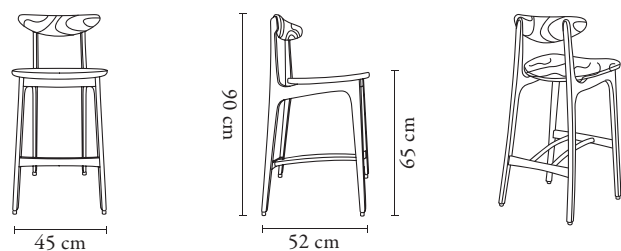

Width: 45 cm

Height: 90 cm

Depth: 52 cm

Seat height: 65 cm

Packaging dimensions: 93 x 48 x 55 cm

Delivery: fully assembled furniture

Net weight: 7,2 kg

Gross weight: 9 kg

100% designed and manufactured in Poland



Ash 04



Ash 04



Bar stools

200-190 BAR STOOL TIMBER M75

Story behind:

A bar version of the Iconic 200-190 Chair designed in the 1960s. It has become the undisputed Icon of Polish Design. The light form of this bar stool and the use of ash with brass details give it a nobility and timelessness that still amazes. The 200-190 Bar Stool Timber is available in 2 sizes - S65 and M75.

Design: 2021 by Agata Górka, based on the 200-190 Chair from 1960s

Legs: solid ash wood with brass finishing

Seat and backrest: plywood

Contract: norm passed EN 16139

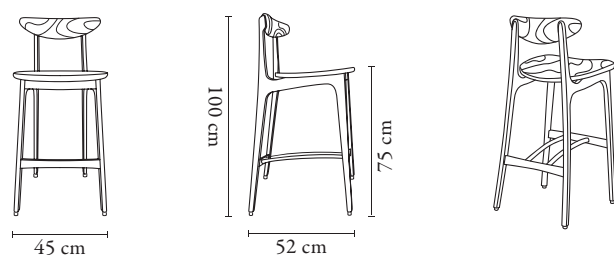

Width: 45 cm

Height: 100 cm

Depth: 52 cm

Seat height: 75 cm

Packaging dimensions: 104 x 49 x 55 cm

Delivery: fully assembled furniture

Net weight: 7,2 kg

Gross weight: 9 kg

100% designed and manufactured in Poland



Ash 04

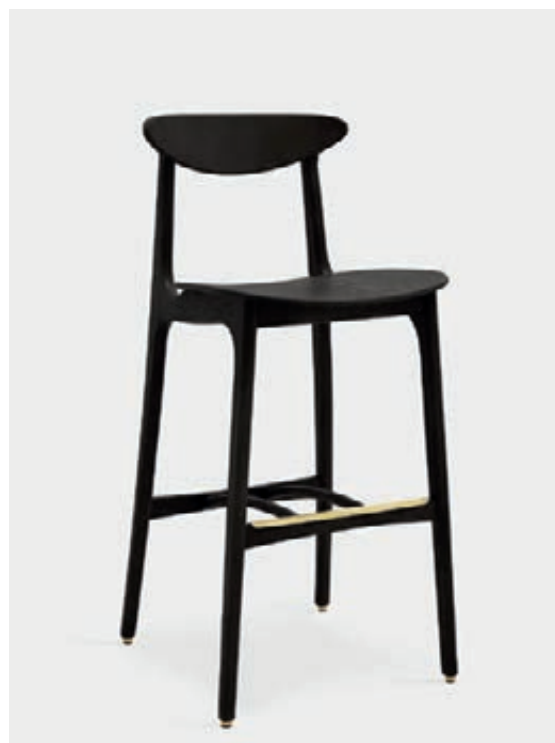

Ash 04



Bar stools

200-190 BAR STOOL BASIC S65

Story behind:

A bar version of the Iconic 200-190 Dining Chair designed in the 1960s. It has become the undisputed Icon of Polish Design. The light form of this upholstered bar stool and the use of ash with brass details give it a nobility and timelessness that still amazes. The 200-190 Bar Stool Basic is available in 2 sizes - S65 and M75.

Design: 2022 by Maciek Cypryk, based on the 200-190 Chair from 1960s

Legs: solid ash wood with brass finishing

Internal structure: plywood

Seat: high resilience foam

Contract: norm passed EN 16139

COM: 1 pc = 1,5 x 1,4 m / 2+ pcs = 1,5 x 1,4 m

COL: 1 pc = 0,5 m², from 4 pcs

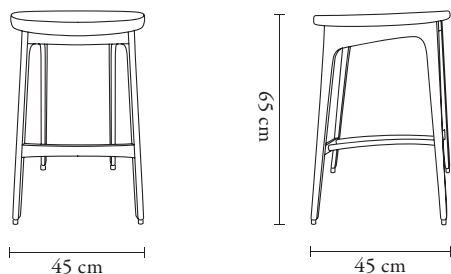

Width: 45 cm

Height: 65 cm

Depth: 45 cm

Packaging dimensions: 80 x 50 x 50 cm

Delivery: fully assembled furniture

Net weight: 6,4 kg

Gross weight: 8 kg

100% designed and manufactured in Poland



Shine Velvet Coll. - Mustard / Ash 03



Shine Velvet Coll. - Mustard / Ash 03

200-190 BAR STOOL BASIC M75

Story behind:

A bar version of the Iconic 200-190 Dining Chair designed in the 1960s. It has become the undisputed Icon of Polish Design. The light form of this upholstered bar stool and the use of ash with brass details give it a nobility and timelessness that still amazes. The 200-190 Bar Stool Basic is available in 2 sizes - S65 and M75.

Design: 2022 by Maciek Cypriak,
based on the 200-190 Chair from 1960s

Legs: solid ash wood with brass finishing

Internal structure: plywood

Seat: high resilience foam

Contract: norm passed EN 16139

COM: 1 pc = 1,5 x 1,4 m / 2+ pcs = 1,5 x 1,4 m

COL: 1 pc = 0,5 m2, from 4 pcs

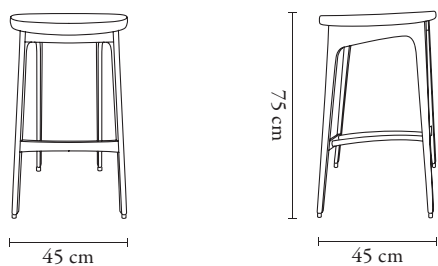

Width: 45 cm

Height: 75 cm

Depth: 45 cm

Packaging dimensions: 80 x 50 x 50 cm

Delivery: fully assembled furniture

Net weight: 6,4 kg

Gross weight: 8 kg

100% designed and manufactured in Poland



Velvet Coll. - Red Brick / Ash 03

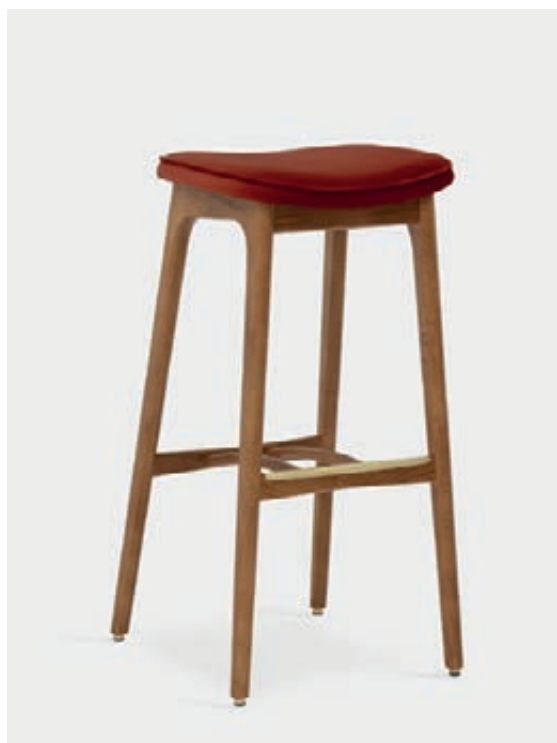

Velvet Coll. - Red Brick / Ash 03

Bar stools

200-190 BAR STOOL BASIC TIMBER S65

Story behind:

A bar version of the Iconic 200-190 Dining Chair designed in the 1960s. It has become the undisputed Icon of Polish Design. The light form of this timber bar stool and the use of ash with brass details give it a nobility and timelessness that still amazes. The 200-190 Bar Stool Basic Timber is available in 2 sizes - S65 and M75.

Design: 2022 by Maciek Cypryk, based on the 200-190 Chair from 1960s

Legs: solid ash wood with brass finishing

Seat: plywood

Contract: norm passed EN 16139

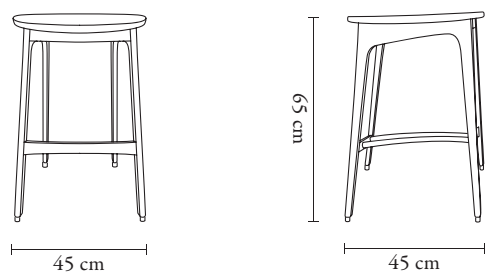

Width: 45 cm

Height: 65 cm

Depth: 45 cm

Packaging dimensions: 80 x 50 x 50 cm

Delivery: fully assembled furniture

Net weight: 6,4 kg

Gross weight: 8 kg

100% designed and manufactured in Poland



Ash 03



Ash 03

200-190 BAR STOOL BASIC TIMBER M75

Story behind:

A bar version of the Iconic 200-190 Dining Chair designed in the 1960s. It has become the undisputed Icon of Polish Design. The light form of this timber bar stool and the use of ash with brass details give it a nobility and timelessness that still amazes. The 200-190 Bar Stool Basic Timber is available in 2 sizes - S65 and M75.

Design: 2022 by Maciek Cypryk, based on the 200-190 Chair from 1960s

Legs: solid ash wood with brass finishing

Seat: plywood

Contract: norm passed EN 16139

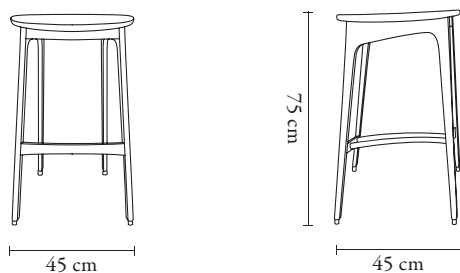

Width: 45 cm

Height: 75 cm

Depth: 45 cm

Packaging dimensions: 80 x 50 x 50 cm

Delivery: fully assembled furniture

Net weight: 6,4 kg

Gross weight: 8 kg

100% designed and manufactured in Poland



Ash 03



Ash 03

Armchairs

366 ARMCHAIR

Story behind:

Icon of Polish Mid-Century Design: the 366 Armchair, designed in the 1962 by Józef Chierowski. For everyone who values comfort enconced in timeless design. Take a seat and bring a piece of history into your living room. We combined 60 years of heritage with the best fabrics and oak wood selected by experienced craftsmen to ensure the greatest comfort in your home.

Original design: Józef Chierowski, 1962

Reedition: 2014 by 366 Concept

Legs: solid oak wood with brass finishing

Internal structure: solid beech wood

Seat: zig zag springs, high resilience foam

Contract: norm passed EN 16139

COM: 1 pc = 1,8 x 1,4 m / 2+ pcs = 1,8 x 1,4 m

COL: 1 pc = 2,2 m2

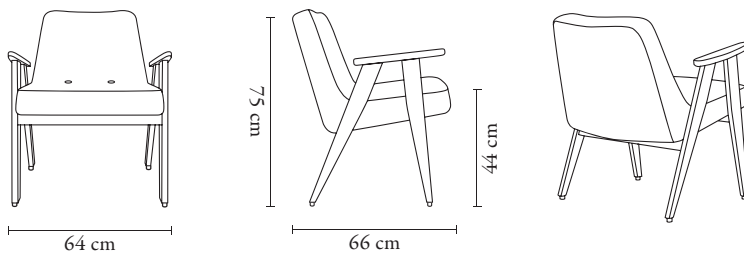

Width: 64 cm

Height: 75 cm

Depth: 66 cm

Seat height: 44 cm

Packaging dimensions: 78 x 68 x 70 cm

Delivery: fully assembled furniture

Net weight: 9,6 kg

Gross weight: 12 kg

100% designed and manufactured in Poland



Velvet Coll. - Red Brick / Oak 03



Shine Velvet Coll. - Mustard / Oak 03



Armchairs

366 METAL BLACK MATT

Story behind:

A masterpiece of Mid-Century Design – the 366 Armchair 300-129 in a metal version, designed in the 1962 by Józef Chierowski, but never manufactured. We've reissued it so you can enjoy unparalleled comfort combined with a new design perspective. Lightweight, extraordinary and minimalist, it is available in brass matt.

Original design: Józef Chierowski, 1962

Reedition: 2014 by 366 Concept, based on the 366 Armchair

Legs: steel with wooden finishing

Armrests: solid oak wood

Internal structure: solid beech wood

Seat: zig zag springs, high resilience foam

Metal: black matt

Contract: norm passed EN 16139

COM: 1 pc = 1,8 x 1,4 m / 2+ pcs = 1,8 x 1,4 m

COL: 1 pc = 2,3 m²

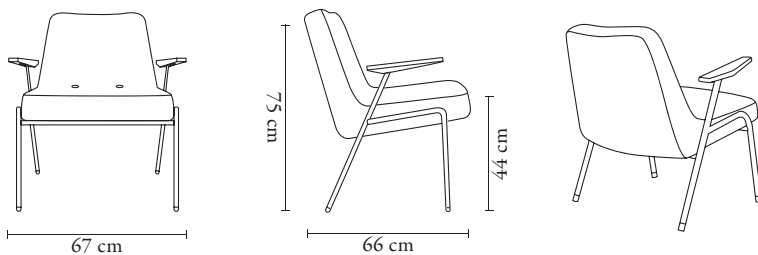

Width: 67 cm

Height: 75 cm

Depth: 66 cm

Seat height: 44 cm

Packaging dimensions: 78 x 71 x 70 cm

Delivery: fully assembled furniture

Net weight: 9,6 kg

Gross weight: 12 kg

100% designed and manufactured in Poland



Velvet Coll. - Indigo / Black Matt / Oak 03



Velvet Coll. - Indigo / Black Matt / Oak 03



Armchairs

366 METAL BRASS MATT

Story behind:

A masterpiece of Mid-Century Design – the 366 Armchair 300-129 in a metal version, designed in the 1962 by Józef Chierowski, but never manufactured. We've reissued it so you can enjoy unparalleled comfort combined with a new design perspective. Have a seat and feel unique. Lightweight, extraordinary and minimalist, it is also available in black matt.

Original design: Józef Chierowski, 1962

Reedition: 2017 by 366 Concept, based on the 366 Armchair

Legs: steel with wooden finishing

Armrests: solid oak wood

Internal structure: solid beech wood

Seat: zig zag springs, high resilience foam

Metal: brass matt

Contract: norm passed EN 16139

COM: 1 pc = 1,8 x 1,4 m / 2 + pcs = 1,8 x 1,4 m

COL: 1 pc = 2,3 m²

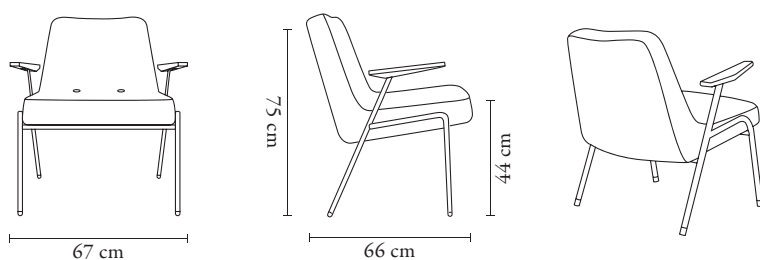

Width: 67 cm

Height: 75 cm

Depth: 66 cm

Seat height: 44 cm

Packaging dimensions: 78 x 71 x 70 cm

Delivery: fully assembled furniture

Net weight: 9,6 kg

Gross weight: 12 kg

100% designed and manufactured in Poland



Velvet Coll. - Olive / Brass Matt / Oak 03



Velvet Coll. - Olive / Brass Matt / Oak 03



Armchairs

366 METAL CLUB BLACK MATT

Story behind:

The metal version of the Mid-Century Design masterpiece has also become available without armrests. The armchair is available in all fabrics and natural leather collections. The metal frame is also available in brass matt finish.

Original design: Józef Chierowski, 1960s

Reedition: 2017 by Agata Górka & Maciek Cypryk, based on the 366 Metal Armchair

Legs: steel with wooden finishing

Internal structure: solid beech wood

Seat: zig zag springs, high resilience foam

Metal: black matt & brass matt

Contract: norm passed EN 16139

COM: 1 pc = 1,8 x 1,4 m / 2+ pcs = 1,8 x 1,4 m

COL: 1 pc = 2,3 m²

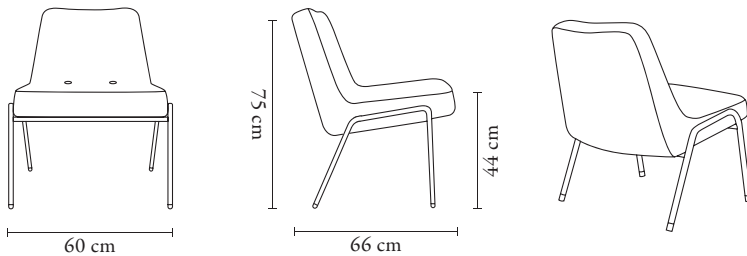

Width: 60 cm

Height: 75 cm

Depth: 66 cm

Seat height: 44 cm

Packaging dimensions: 78 x 71 x 70 cm

Delivery: fully assembled furniture

Net weight: 8,8 kg

Gross weight: 11 kg

100% designed and manufactured in Poland



Boucle Coll. - Mustard / Black Matt / Oak 03



Shine Velvet Coll. - Mustard / Black Matt



Armchairs

366 JUNIOR ARMCHAIR

Story behind:

The Icon of Polish Design in miniature, namely the 366 Junior Armchair. It was created based on the most famous Polish Design project and proportionally scaled down for children aged 3 to 12 years.

Original design: Józef Chierowski, 1962

Reedition: 2014 by Agata Górka, based on the 366 Armchair

Legs: solid oak wood with brass finishing

Internal structure: solid beech wood

Seat: zig zag springs, high resilience foam

Contract: norm passed EN 16139

COM: 1 pc = 1,3 x 1,4 m / 2+ pcs = 1,3 x 1,4 m

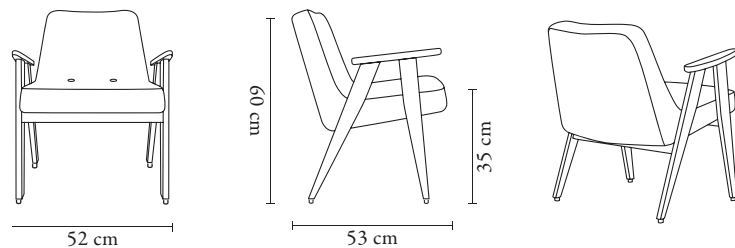

Width: 52 cm

Height: 60 cm

Depth: 53 cm

Seat height: 35 cm

Packaging dimensions: 64 x 55 x 64 cm

Delivery: fully assembled furniture

Net weight: 6,4 kg

Gross weight: 8 kg

100% designed and manufactured in Poland

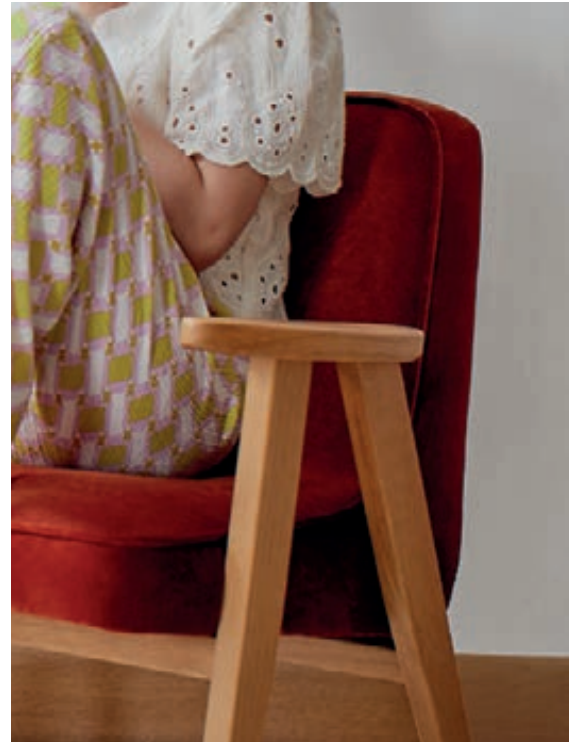

Velvet Coll. - Red Brick / Oak 03



Boucle Coll. - Mustard / Oak 02



Armchairs

BUNNY ARMCHAIR

Story behind:

A reissue of the classic 300-177 Armchair, which got its name from the characteristic armrests in the shape of rabbit ears.

One of the more extravagant designs produced in Poland in the 1960s, with a timeless body that never ceases to impress.

Original design: 1960s

Reedition: 2015 by 366 Concept

Legs: solid oak wood with brass finishing

Internal structure: solid beech wood

Seat: zig zag springs, high resilience foam

Contract: norm passed EN 16139

COM: 1 pc = 1,8 x 1,4 m / 2+ pcs = 1,8 x 1,4 m

COL: 1 pc = 2,2 m²

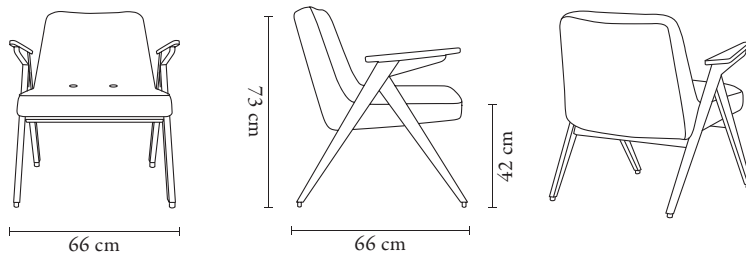

Width: 66 cm

Height: 73 cm

Depth: 66 cm

Seat height: 42 cm

Packaging dimensions: 78 x 71 x 70 cm

Delivery: fully assembled furniture

Net weight: 10,4 kg

Gross weight: 13 kg

100% designed and manufactured in Poland

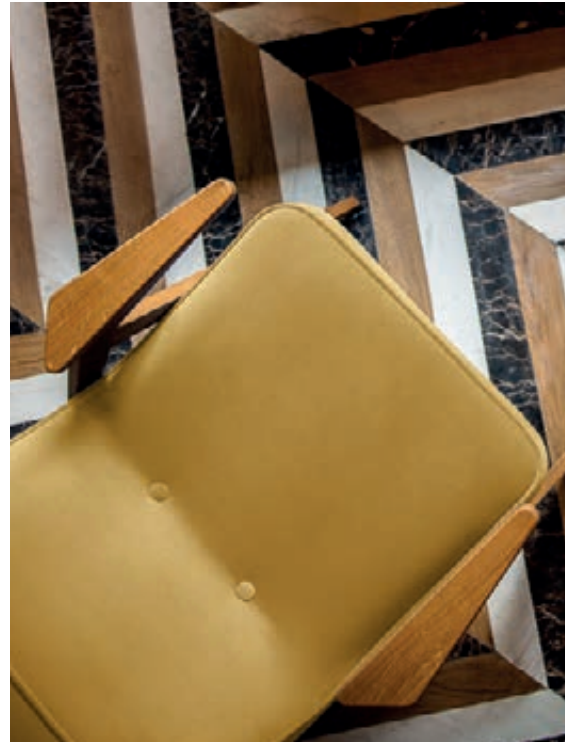

Shine Velvet Coll. - Mustard / Oak 03



Shine Velvet Coll. - Mustard / Oak 03



The Iconic Interior
VANITY FAIR PORTRAITS

Armchairs

FOX LOUNGE CHAIR

Story behind:

The beauty of Design Icons – the Fox Lounge Chair, designed in the 1960s. One of the most comfortable and exclusive armchairs. A contemporary reissue by 366 Concept just for you. Its exclusive wooden design and exquisitely comfortable seat were once the pride of every Polish club and restaurant. Made of premium quality, hand-selected solid ash and finished with brass details for a touch of refinement.

Original design: 1960s

Reedition: 2017 by 366 Concept

Legs: solid ash wood with brass finishing

Internal structure: solid beech wood

Seat: zig zag springs, high resilience foam

Contract: norm passed EN 16139

COM: 1 pc = 1,8 x 1,4 m / 2 + pcs = 1,8 x 1,4 m

COL: 1 pc = 2,3 m²

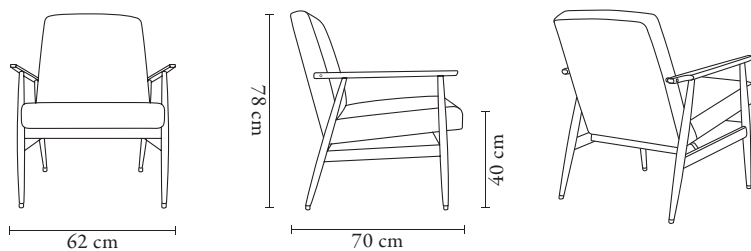

Width: 62 cm

Height: 78 cm

Depth: 70 cm

Seat height: 40 cm

Packaging dimensions: 82 x 66 x 74 cm

Delivery: fully assembled furniture

Net weight: 10,4 kg

Gross weight: 13 kg

100% designed and manufactured in Poland



Marble Coll. - Mustard / Ash 03



Marble Coll. - Mustard / Ash 03



Armchairs

FOX CLUB LOUNGE CHAIR

Story behind:

The design of Fox Club Lounge Chair was inspired by the Fox Lounge Chair from 1960s. This modern sophisticated project is both sublime and slim. Thanks to trapezoidal shaped wooden legs and lack of armrests it will fit to any modern space.

Original design: 1960s

Reedition: 2017 by 366 Concept, based on the Fox Lounge Chair

Legs: solid ash wood with brass finishing

Internal structure: solid beech wood

Seat: zig zag springs, high resilience foam

Contract: norm passed EN 16139

COM: 1 pc = 1,8 x 1,4 m / 2+ pcs = 1,8 x 1,4 m

COL: 1 pc = 2,3 m²

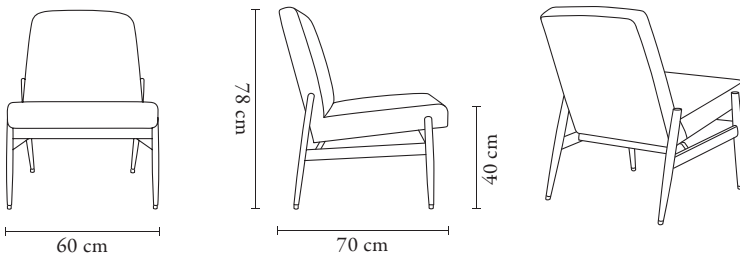

Width: 60 cm

Height: 78 cm

Depth: 70 cm

Seat height: 40 cm

Packaging dimensions: 82 x 66 x 74 cm

Delivery: fully assembled furniture

Net weight: 9,6 kg

Gross weight: 12 kg

100% designed and manufactured in Poland



Velvet Coll. - Olive / Ash 03



Boucle Coll. - Mustard / Ash 03



Armchairs

FOX METAL LOUNGE CHAIR

Story behind:

The beauty of Design Icons - the Fox Metal Lounge Chair, design is based on the wooden version of the Fox Lounge Chair. It is one of the most comfortable and exclusive chairs. This unique metal structure, combined with an extremely comfortable seat, made this armchair one of the most unique furniture pieces in our portfolio. Armrests made of hand-selected solid ash add even more warmth to this structure.

Original design: 1960s

Reedition: 2021 by Maciek Cypriak, based on the Fox Lounge Chair

Legs: steel

Armrest: solid ash wood

Internal structure: solid beech wood

Seat: zig zag springs, high resilience foam

Metal: black matt

Contract: norm passed EN 16139

COM: 1 pc = 1,8 x 1,4 m / 2 + pcs = 1,8 x 1,4 m

COL: 1 pc = 2,3 m²

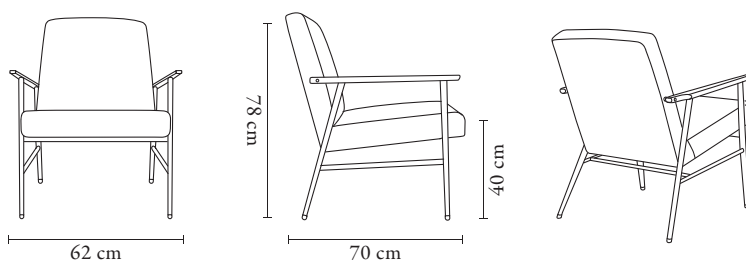

Width: 62 cm

Height: 78 cm

Depth: 70 cm

Seat height: 40 cm

Packaging dimensions: 82 x 66 x 80 cm

Delivery: fully assembled furniture

Net weight: 10,4 kg

Gross weight: 13 kg

100% designed and manufactured in Poland

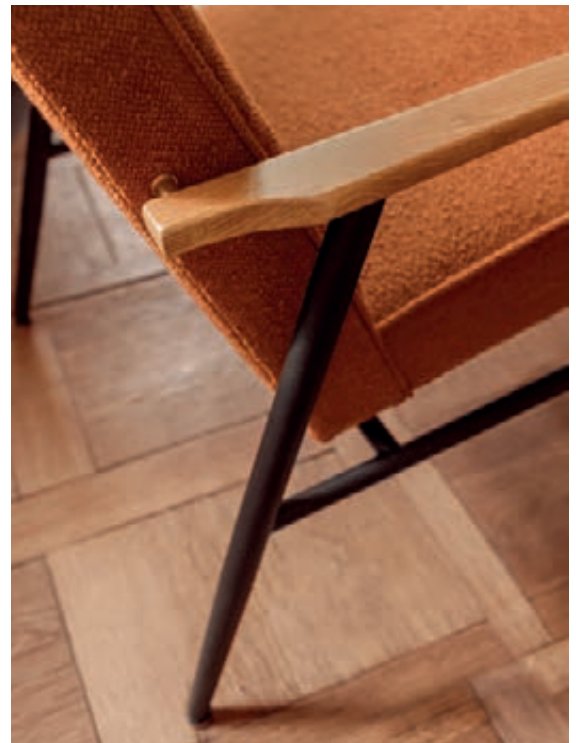

Boucle Coll. - Sierra / Black Matt / Ash 03



Boucle Coll. - Sierra / Black Matt / Ash 03



Armchairs

STEFAN LOUNGE CHAIR

Story behind:

The Stefan Lounge Chair was designed as the Type 300-139 chair in the early 1960s as an attempt to create Poland's export seater. The piece features a simple modernist and organic form enriched by gently contoured armrests, reminiscent of Danish design classics. The upholstery is formed by 2 independent and portable cushions made of high-density foam to provide outstanding comfort. To combine aesthetics with functionality, cushion covers can be easily washed or exchanged for new ones to change the look of the furniture at any time.

Original design: 1962

Reedition: 2022 by 366 Concept

Legs: solid oak wood with brass finishing

Backrest: solid oak wood

Seat: high resilience foam

Contract: norm passed EN 16139

COM: 1 pc = 1,7 x 1,4 m / 2+ pcs = 1,7 x 1,4 m

COL: 1 pc = 1,7 m2

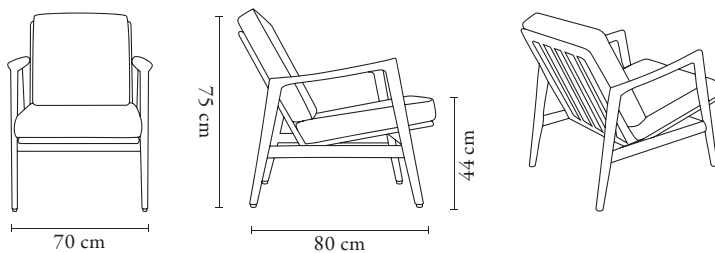

Width: 70 cm

Height: 75 cm

Depth: 80 cm

Seat height: 44 cm

Packaging dimensions: 82 x 66 x 80 cm

Delivery: fully assembled furniture

Net weight: 10 kg

100% designed and manufactured in Poland



Cord Coll. - Grass / Oak 03



Cord Coll. - Grass / Oak 03



Rocking chairs

366 ROCKING CHAIR

Story behind:

The 366 Rocking Chair design is based on the Iconic 366 Armchair designed by Józef Chierowski in 1962. An ideal alternative to a traditional armchair in Mid-Century interiors and also in a modern space adding a touch of nostalgia. Ideal for an afternoon of leisure with a cup of tea or a good book. For those who fancy rest in motion.

Original design: Józef Chierowski, 1962

Reedition: 2014 by Maciek Cypryk, based on the 366 Armchair

Legs: solid oak wood with brass finishing

Internal structure: solid beech wood

Seat: zig zag springs, high resilience foam

Contract: norm passed EN 16139

COM: 1 pc = 1,8 x 1,4 m / 2+ pcs = 1,8 x 1,4 m

COL: 1 pc = 2,2 m2

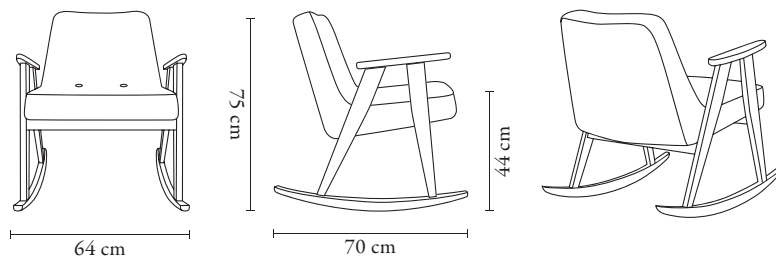

Width: 64 cm

Height: 75 cm

Depth: 70 cm

Seat height: 44 cm

Packaging dimensions: 78 x 70 x 68 cm

Delivery: fully assembled furniture

Net weight: 10,4 kg

Gross weight: 13 kg

100% designed and manufactured in Poland



Boucle Coll. - Beige / Oak 03



Boucle Coll. - Beige / Oak 03

366 JUNIOR ROCKING CHAIR

Story behind:

The 366 Junior Rocking Chair is a seating option prepared for both the youngest occupants of the home and parents who want to create a highly esthetical and form-fitting space in the nursery. It was designed on the basis of the 366 Armchair designed by Józef Chierowski, as an addition to the 366 Series.

Original design: Józef Chierowski, 1962

Reedition: 2014 by Agata Górka, based on the 366 Armchair

Legs: solid oak wood with brass finishing

Internal structure: solid beech wood

Seat interior: zig zag springs, high resilience foam

Contract: norm passed EN 16139

COM: 1 pc = 1,3 x 1,4 m / 2+ pcs = 1,3 x 1,4 m

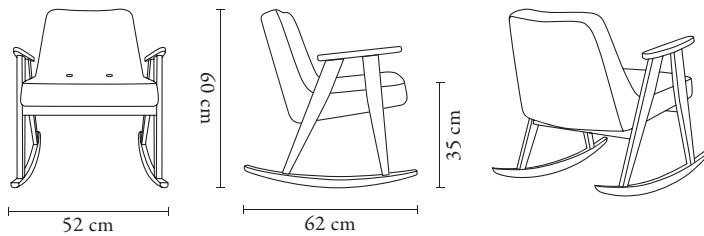

Width: 52 cm

Height: 60 cm

Depth: 62 cm

Seat height: 35 cm

Packaging dimensions: 64 x 55 x 64 cm

Delivery: fully assembled furniture

Net weight: 7,2 kg

Gross weight: 9 kg

100% designed and manufactured in Poland



Velvet Coll. - Mint / Oak 03



Velvet Coll. - Mint / Oak 03

Rocking chairs

FOX ROCKING CHAIR

Story behind:

Rocking version of the Fox Lounge Chair, is one of the most comfortable armchairs in Polish Design. Produced by the 366 Concept, with attention to quality and details. The structure of the chair is made of solid ash. The Fox Lounge Chair is considered an Icon of Polish Design.

Original design: 1960s

Reedition: 2017 by Agata Górka & Maciek Cypryk, based on the Fox Lounge Chair

Legs: solid ash wood with brass finishing

Internal structure: solid beech wood

Seat interior: zig zag springs, high resilience foam

Contract: norm passed EN 16139

COM: 1 pc = 1,8 x 1,4 m / 2 + pcs = 1,8 x 1,4 m

COL: 1 pc = 2,3 m2

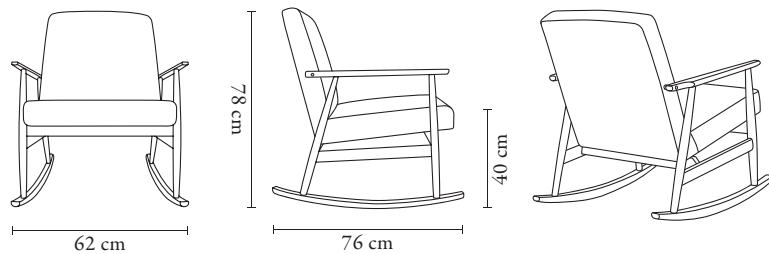

Width: 62 cm

Height: 78 cm

Depth: 76 cm

Seat height: 40 cm

Packaging dimensions: 82 x 66 x 80 cm

Delivery: fully assembled furniture

Net weight: 11,2 kg

Gross weight: 14 kg

100% designed and manufactured in Poland



Coco Coll. - Mustard / Ash 03



Coco Coll. - Mustard / Ash 03



Sofas

366 2-SEATER

Story behind:

Meet the exquisitely comfortable 366 2-Seater inspired by the Iconic 366 Armchair. A great choice for couples and all those who like to cuddle. The 366 2-Seater is a complete match for both minimalistic, modern and sublime interiors.

Original design: Józef Chierowski, 1962

Reedition: 2014 by Agata Górka, based on the 366 Armchair

Legs: solid oak wood with brass finishing

Internal structure: solid beech wood

Seat: zig zag springs, high resilience foam

Contract: norm passed EN 16139

COM: 1 pc = 3,0 x 1,4 m / 2+ pcs = 3,0 x 1,4 m

COL: 1 pc = 3,9 m²

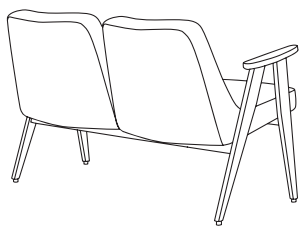
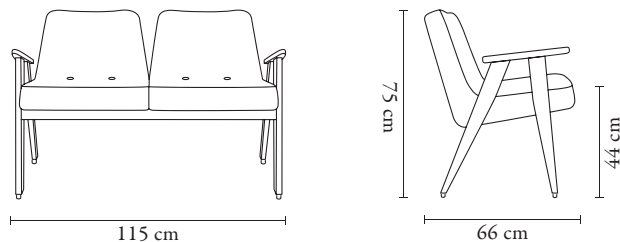

Width: 115 cm

Height: 75 cm

Depth: 66 cm

Seat height: 44 cm

Packaging dimensions: 77 x 120 x 68 cm

Delivery: fully assembled furniture

Net weight: 13,6 kg

Gross weight: 17 kg

100% designed and manufactured in Poland



Velvet Coll. - Indigo / Oak 03



Velvet Coll. - Indigo / Oak 03



Sofas

366 METAL 2-SEATER

Story behind:

We created the 366 Metal 2-Seater based on the pattern of the 366 Metal Armchair, which was designed in the 1960s, but never manufactured. Thanks to a double dose of timeless design, this is an excellent choice for people who like nothing better than spending time together in their modern design apartment. Lightweight, extraordinary and minimalist - ideal solution for a variety of interiors.

Original design: Józef Chierowski, 1962

Reedition: 2017 by Agata Górka, based on the 366 Metal Armchair

Legs: black matt with wooden finishing

Armrests: solid oak wood

Internal structure: solid beech wood

Seat interior: zig zag springs, high resilience foam

Contract: norm passed EN 16139

COM: 1 pc = 2,85 x 1,4 / 2+ pcs = 2,85 x 1,4 m

COL: 1 pc = 3,9 m²

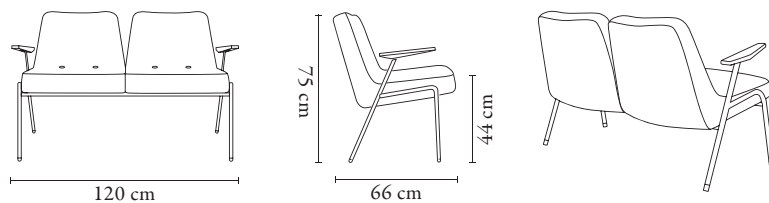

Width: 120 cm

Height: 75 cm

Depth: 66 cm

Seat height: 44 cm

Packaging dimensions: 78 x 126 x 70 cm

Delivery: fully assembled furniture

Net weight: 13,6 kg

Gross weight: 17 kg

100% designed and manufactured in Poland



Boucle Coll. - Snow / Black Matt / Oak 03



Boucle Coll. - Snow / Black Matt / Oak 03



Sofas

BUNNY 2-SEATER

Story behind:

The Bunny 2-Seater was based on the Icon of Polish Design – the 300-177 Armchair, designed by Józef Chierowski.

The small size and comfort make it ideal for apartments and commercial premises. The furniture from Bunny Series are made of solid oak with brass finishing.

Original design: 1960s

Reedition: 2015 by Agata Górka, based on the Bunny Armchair

Legs: solid oak wood with brass finishing

Internal structure: solid beech wood

Seat interior: zig zag springs, high resilience foam

Contract: norm passed EN 16139

COM: 1 pc = 2,85 x 1,4 m / 2+ pcs = 2,85 x 1,4 m

COL: 1 pc = 3,5 m²

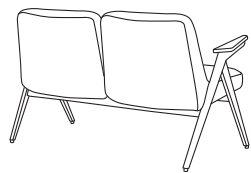
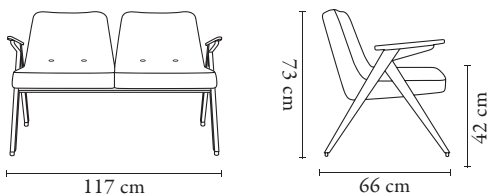

Width: 117 cm

Height: 75 cm

Depth: 66 cm

Seat height: 42 cm

Packaging dimensions: 126 x 78 x 70 cm

Delivery: fully assembled furniture

Net weight: 13,6 kg

Gross weight: 17 kg

100% designed and manufactured in Poland



Velvet Coll. - Bottle Green / Oak 03



Velvet Coll. - Bottle Green / Oak 03



Sofas

FOX 2-SEATER

Story behind:

Relax on the extremely comfortable Fox 2-Seater. Its design is based on the original design of the Fox Lounge Chair, which we have doubled. The wide comfortable seat and delicate wooden structure of the legs and armrests create a simple and clear form. Hand-selected solid ash wood finished with brass details gives the Fox 2-Seater a touch of refinement.

Original design: 1960s

Reedition: 2017 by Agata Górká, based on the Fox Lounge Chair

Legs: solid ash wood with brass finishing

Internal structure: solid beech wood

Seat interior: zig zag springs, high resilience foam

Contract: norm passed EN 16139

COM: 1 pc = 2,8 x 1,4 m / 2+ pcs = 2,8 x 1,4 m

COL: 1 pc = 4 m²

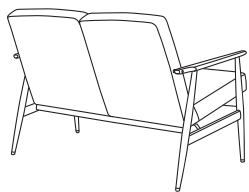
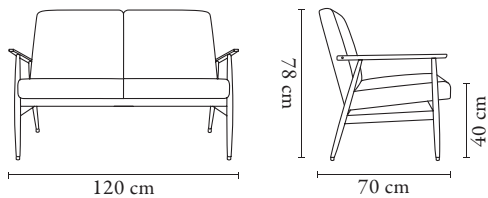

Width: 120 cm

Height: 78 cm

Depth: 70 cm

Seat height: 40 cm

Packaging dimensions: 82 x 124 x 74 cm

Delivery: fully assembled furniture

Net weight: 13,6 kg

Gross weight: 17 kg

100% designed and manufactured in Poland



Shine Velvet Coll. - Mustard / Ash 03



Shine Velvet Coll. - Mustard / Ash 03



Sofas

FOX SOFA

Story behind:

Relax on the extremely comfortable Fox Sofa. Its design is based on the original design of the Fox Lounge Chair, which we have doubled. The wide comfortable seat and delicate wooden structure of the legs and armrests create a simple and clear form. Hand-selected solid ash wood finished with brass details gives the Fox Sofa a touch of refinement.

Original design: 1960s

Reedition: 2017 by Agata Górka,
based on the Fox Lounge Chair

Legs: solid ash wood with brass finishing

Internal structure: solid beech wood

Seat interior: zig zag springs, high resilience foam

Contract: norm passed EN 16139

COM: 1 pc = 3,0 x 1,4 m / 2+ pcs = 3,0 x 1,4 m

COL: 1 pc = 4,5 m²

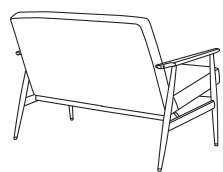
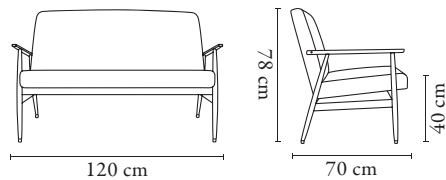

Width: 120 cm

Height: 78 cm

Depth: 70 cm

Seat height: 40 cm

Packaging dimensions: 82 x 124 x 74 cm

Delivery: fully assembled furniture

Net weight: 13,6 kg

Gross weight: 17 kg

100% designed and produced in Poland



Coco Coll. - Creme / Ash 03



Coco Coll. - Creme / Ash 03

366 3-SEATER

Story behind:

Meet the exquisitely comfortable 366 3-Seater inspired by an Iconic 366 Armchair. 3-Seater sofa design is based on the 366 Armchair – an Iconic Polish armchair designed by Józef Chierowski in 1962. It will become an ideal complement to vintage interiors, but it will also look great in a modern space adding a touch of nostalgia to it.

Original design: Józef Chierowski, 1962

Reedition: 2014 by Agata Górka, based on the 366 Armchair

Legs: solid oak wood with brass finishing

Internal structure: solid beech wood

Seat Interior: zig zag springs, high resilience foam

Contract: norm passed EN 16139

COM: 1 pc = 4,2 x 1,4 m / 2+ pcs = 4,2 x 1,4 m

COL: 1 pc = 5,9 m2

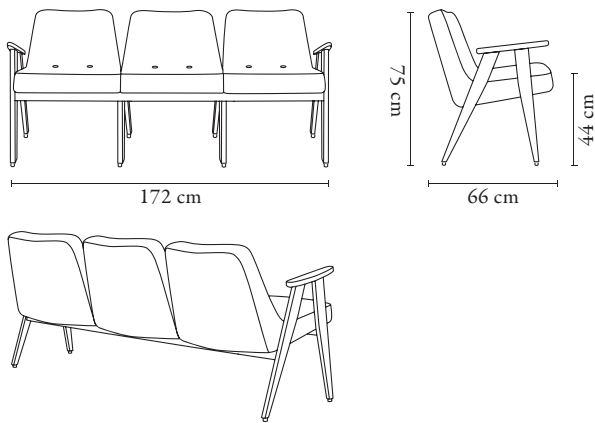

Width: 172 cm

Height: 75 cm

Depth: 66 cm

Seat height: 44 cm

Packaging dimensions: placed on a pallet

Delivery: fully assembled furniture

Net weight: 21,6 kg

Gross weight: 27 kg

100% designed and manufactured in Poland



Velvet Coll. - Olive / Oak 03



Velvet Coll. - Olive / Oak 03

Sofas

FOX CLUB SOFA

Story behind:

Relax on the extremely comfortable Fox Club Sofa.

Its design is based on the original design of the Fox Lounge Chair, which we have doubled. Hand-selected solid ash wood finished with brass details gives the Fox Club Sofa a touch of refinement.

Original design: 1960s

Reedition: 2017 by Agata Górka,

based on the Fox Lounge Chair

Legs: solid ash wood with brass finishing

Internal structure: solid beech wood

Seat interior: zig zag springs, high resilience foam

Contract: norm passed EN 16139

COM: 1 pc = 3,0 x 1,4 m / 2+ pcs = 3,0 x 1,4 m

COL: 1 pc = 4,5 m²

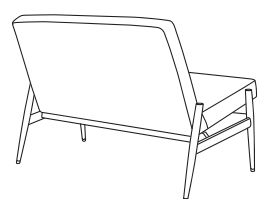
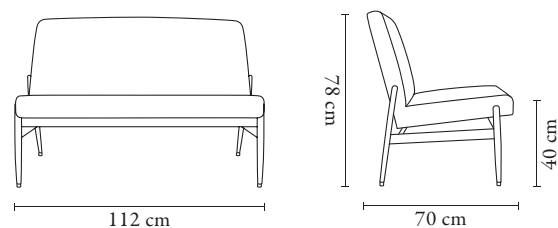

Width: 112 cm

Height: 78 cm

Depth: 70 cm

Seat height: 40 cm

Packaging dimensions: 80 x 120 x 74 cm

Delivery: fully assembled furniture

Net weight: 12,8 kg

Gross weight: 16 kg

100% designed and manufactured in Poland



Velvet Coll. - Olive / Ash 03



Velvet Coll. - Olive / Ash 03



Sofas

FOX LONG SOFA

Story behind:

Relax on the extremely comfortable Fox Long Sofa. Its design is based on the original design of the Fox Lounge Chair, which we have doubled. The wide comfortable seat and delicate wooden structure of the legs and armrests create a simple and clear form. The sofa is made of hand-selected solid ash wood, finished with brass details.

Original design: 1960s

Reedition: 2017 by Agata Górká,
based on the Fox Lounge Chair

Legs: solid ash wood with brass finishing

Internal structure: solid beech wood

Seat interior: zig zag springs, high resilience foam

Contract: norm passed EN 16139

COM: 1 pc = 4,0 x 1,4 m / 2+ pcs = 4,0 x 1,4 m

COL: 1 pc = 6 m²

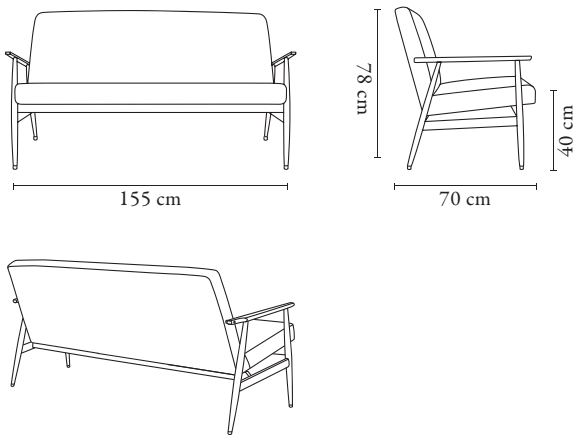

Width: 155 cm

Height: 78 cm

Depth: 70 cm

Seat height: 40 cm

Packaging dimensions: 80 x 120 x 74 cm

Delivery: fully assembled furniture

Net weight: 13,6 kg

Gross weight: 17 kg

100% designed and manufactured in Poland



Shine Velvet Coll. - Sierra / Ash 03



Shine Velvet Coll. - Sierra / Ash 03



Sofas

FOX 3-SEATER

Story behind:

Relax on the extremely comfortable Fox 3-Seater.

Its design is based on the original design of the Fox Lounge

Chair, which we have extended. Hand-selected solid ash wood

finished with brass details gives the Fox 3-Seater a touch

of refinement.

Original design: 1960s

Reedition: 2017 by Agata Górka,

based on the Fox Lounge Chair

Legs: solid ash wood with brass finishing

Internal structure: solid beech wood

Seat Interior: zig zag springs, high resilience foam

Contract: norm passed EN 16139

COM: 1 pc = 4,0 x 1,4 m / 2+ pcs = 4,0 x 1,4 m

COL: 1 pc = 6,6 m²

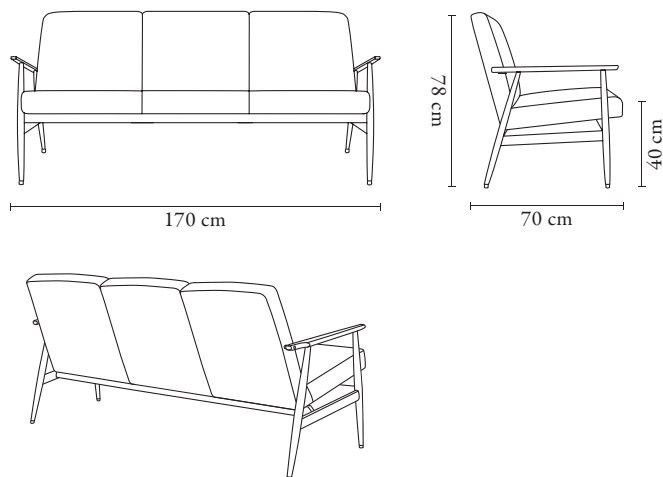

Width: 170 cm

Height: 78 cm

Depth: 70 cm

Seat height: 40 cm

Packaging dimensions: placed on a pallet

Delivery: fully assembled furniture

Net weight: 21,6 kg

Gross weight: 27 kg

100% designed and manufactured in Poland



Cord Coll. - Creme / Ash 03



Cord Coll. - Creme / Ash 03



Sofas

STEFAN 2-SEATER

Story behind:

The Stefan 2-Seater has been created based on the Icon of Polish Design – The Stefan Lounge Chair – designed in 1962. The frame of the 2-Seater is made of solid oak wood, while the backrest is decorated with wooden tiers. The upholstery in this case is formed by 4 loose rectangular cushions. The Stefan Lounge Chair was a Polish export commodity and thus represented the upper class among furniture manufactured at the time. The furniture has a modernist form and a simple design, enriched by gently contoured armrests, reminiscent of classics of Danish design.

Original design: 1962

Reedition: 2022 by Agata Górką,

based on the Stefan Lounge Chair 300-139

Legs: solid oak wood with brass finishing

Backrest: solid oak wood

Seat: high resilience foam

Contract: norm passed EN 16139

COM: 1 pc = 3,4 x 1,4 m / 2+ pcs = 3,4 x 1,4 m

COL: 1 pc = 3,4 m²

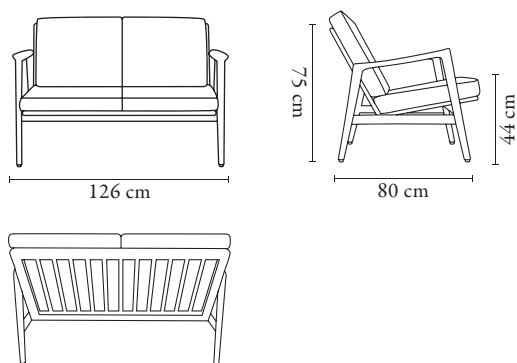

Width: 126 cm

Height: 75 cm

Depth: 80 cm

Seat height: 44 cm

Packaging dimensions: placed on a pallet

Delivery: fully assembled furniture

Net weight: 25 kg

100% designed and manufactured in Poland



Braid Coll. - Sierra / Oak 02



Braid Coll. - Sierra / Oak 02



Sofas

STEFAN SOFA

Story behind:

The Stefan Sofa has been created based on the Icon of Polish Design – The Stefan Lounge Chair – designed in 1962. The frame of the Sofa is made of solid oak wood, while the backrest is decorated with wooden tiers. The upholstery in this case is formed by rectangular cushions. The Stefan Lounge Chair was a Polish export commodity and thus represented the upper class among furniture manufactured at the time. The sofa has a modernist form and a simple design, enriched by gently contoured armrests, reminiscent of classics of Danish design.

Original design: 1962

Reedition: 2022 by Agata Górká,
based on the Stefan Lounge Chair 300-139

Legs: solid oak wood with brass finishing

Backrest: solid oak wood

Seat: high resilience foam

Contract: norm passed EN 16139

COM: 1 pc = 3,4 x 1,4 m / 2+ pcs = 3,4 x 1,4 m

COL: 1 pc = 4 m²

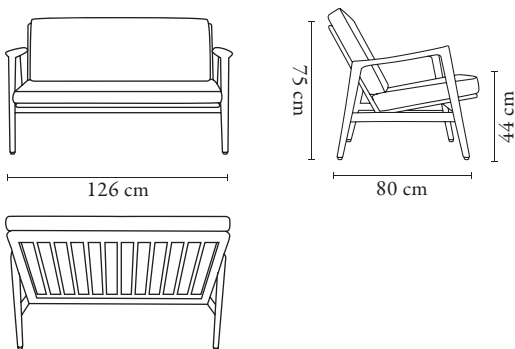

Width: 126 cm

Height: 75 cm

Depth: 80 cm

Seat height: 44 cm

Packaging dimensions: placed on a pallet

Delivery: fully assembled furniture

Net weight: 25 kg

100% designed and manufactured in Poland



Boucle Coll. - Snow / Oak 02



Boucle Coll. - Snow / Oak 02



Sofas

FOX METAL 2-SEATER

Story behind:

The Fox 2-Seater with a metal finish is a contemporary version of the Iconic Fox Lounge Chair that differs from the original by the material of which the structure is made. Divided into 2 parts, the seat clearly reflects the relationship with the classic Fox Lounge Chair. The metal finish gives the Fox Metal 2-Seater an expressive character that still amazes.

Original design: 1960s

Reedition: 2021 by Maciek Cypryk, based on the design of the Fox Metal Lounge Chair

Legs: black matt

Armrests: solid ash wood

Internal structure: solid beech wood

Seat interior: zig zag springs, high resilience foam

Contract: norm passed EN 16139

COM: 1 pc = 2,8 x 1,4 m / 2+ pcs = 2,8 x 1,4 m

COL: 1 pc = 4,5 m²

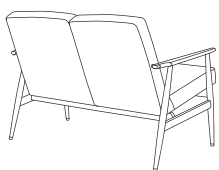
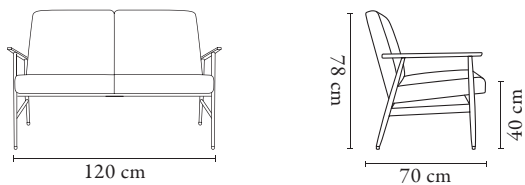

Width: 120 cm

Height: 78 cm

Depth: 70 cm

Seat height: 40 cm

Package dimensions: 124 x 82 x 74 cm

Delivery: fully assembled furniture

Net weight: 13,6 kg

100% designed and manufactured in Poland



Velvet Coll. - Olive / Black Matt / Ash 03



Velvet Coll. - Olive / Black Matt / Ash 03

FOX METAL SOFA

Story behind:

The Fox Sofa with a metal finish is a contemporary version of the iconic Fox Lounge Chair that differs from the original by the material of which the structure is made. Divided into 2 parts, the seat clearly reflects the relationship with the classic Fox Lounge Chair. The metal finish gives the Fox Metal Sofa an expressive character that still amazes.

Original design: 1960s

Reedition: 2021 by Maciek Cypryk, based on the design of the Fox Metal Lounge Chair

Legs: black matt

Armrests: solid ash wood

Internal structure: solid beech wood

Seat interior: zig zag springs, high resilience foam

Contract: norm passed EN 16139

COM: 1 pc = 3,0 x 1,4 m / 2+ pcs = 3,0 x 1,4 m

COL: 1 pc = 4,5 m²

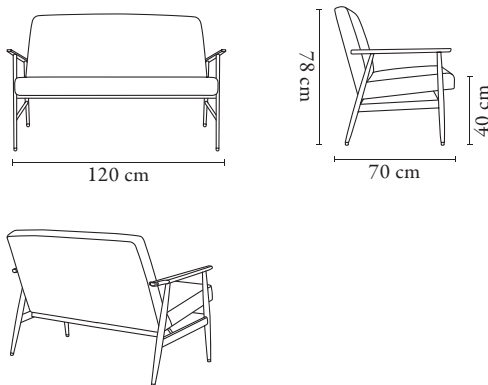

Width: 120 cm

Height: 78 cm

Depth: 70 cm

Seat height: 40 cm

Package dimensions: 124 x 82 x 74 cm

Delivery: fully assembled furniture

Net weight: 13,6 kg

100% designed and manufactured in Poland

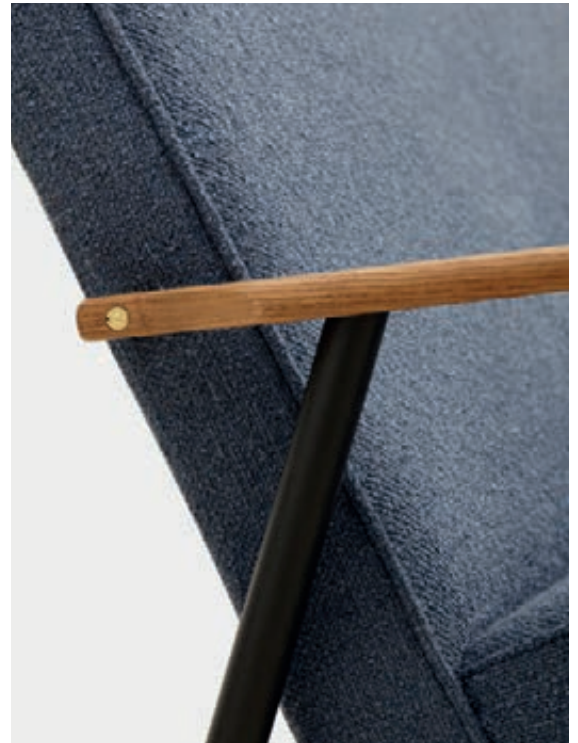

Boucle Coll. - Denim / Black Matt / Ash 03



Boucle Coll. - Denim / Black Matt / Ash 03

Footrests

FOX FOOTREST

Story behind:

The Fox Footrest is the ideal addition to the Fox seats – lounge chairs, club chairs and sofas. Sit comfortably put your feet on the footrest and enjoy a good book. Hand-selected ash wood and brass provide an sublime finish.

Design: 2017 by Agata Górką, based on the Fox Lounge Chair

Legs: solid ash wood with brass finishing

Internal structure: solid beech wood

Seat interior: zig zag springs, high resilience foam

Contract: norm passed EN 16139

COM: 1 pc = 2,0 x 1,4 m / 2+ pcs = 2,0 x 1,4 m

COL: 1 pc = 1,3 m², from 2 pcs

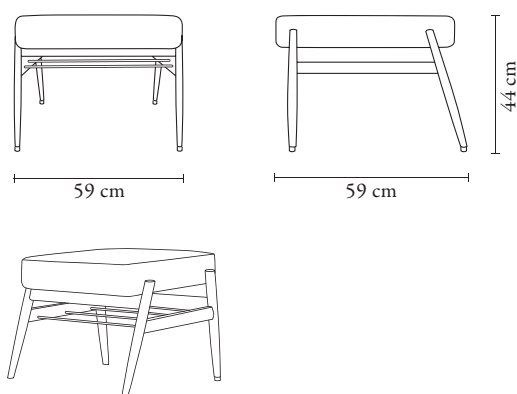

Width: 59 cm

Height: 44 cm

Depth: 59 cm

Packaging dimensions: 48 x 63 x 63 cm

Delivery: fully assembled furniture

Net weight: 5,6 kg

Gross weight: 7 kg

100% designed and manufactured in Poland



Marble Coll. - White / Ash 03



Marble Coll. - White / Ash 03



MONTE CARLO
CAPRI

LUXE |

HELMUT NEWTON |

OSCAR DE LA RUA
THE ART OF THE
CAMP

holiday

Benches

200-190 BENCH

Story behind:

The 200-190 Bench is based on the Iconic 200-190 Chair, designed in the 1960s. It became an unquestionable Icon of Polish Design thanks to its beauty and refinement.

The upholstered light form, as well as the use of ash with brass details, gives it an air of nobility and timelessness that continues to impress.

Original design: 1960s

Reedition: 2020 by Agata Górka, based on the 200-190 Chair

Legs: solid ash wood with brass finishing

Internal structure: solid beech wood

Seat: zig zag springs, high resilience foam

Contract: norm passed EN 16139

COM: 1 pc = 2,8 x 1,4 m / 2+ pcs = 2,8 x 1,4 m

COL: 1 pc = 1,2 m², from 2 pcs

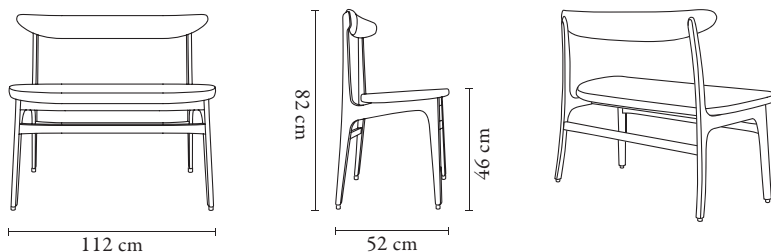

Width: 112 cm

Height: 82 cm

Depth: 52 cm

Seat height: 46 cm

Packaging dimensions: 85 x 115 x 55 cm

Delivery: fully assembled furniture

Net weight: 10,4 kg

Gross weight: 13 kg

100% designed and manufactured in Poland



Boucle Coll. - Snow / Ash 03



Boucle Coll. - Snow / Ash 03



HELMUT NEWTON

Benches

FOX BENCH 90

Story behind:

The Fox Bench complements the Fox Series. Its design is based on the Design Icon from the 1960s. The subtle, thin legs and wide, comfortable seat create a simple form. The Fox Bench is an ideal piece of furniture for the hall, wardrobe, or bedroom, as a low auxiliary piece of furniture. This unique furniture piece is made of ash wood and finished with brass details.

Original design: 1960s

Rededition: 2017 by Agata Górka, based on the Fox Footrest

Legs: solid ash wood with brass finishing

Internal structure: solid beech wood

Seat interior: zig zag springs, high resilience foam

Contract: norm passed EN 16139

COM: 1 pc = 1,7 x 1,4 m / 2+ pcs = 1,7 x 1,4 m

COL: 1 pc = 1,6 m², from 2 pcs

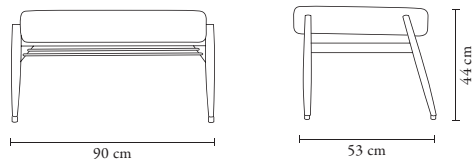

Width: 90 cm

Height: 44 cm

Depth: 53 cm

Packaging dimensions: 48 x 94 x 49 cm

Delivery: fully assembled furniture

Net weight: 7,2 kg

Gross weight: 9 kg

100% designed and manufactured in Poland



Velvet Coll. - Sierra / Ash 03



Shine Velvet Coll. - Sierra / Ash 05

FOX BENCH 125

Story behind:

The Fox Bench complements the Fox Series. Its design is based on the Design Icon from the 1960s. The subtle, thin legs and wide, comfortable seat create a simple form. The Fox Bench is a ideal piece of furniture for the hall, wardrobe, or bedroom, as a low auxiliary piece of furniture. This unique furniture piece is made of ash wood and finished with brass details.

Original design: 1960s

Reedition: 2017 by Agata Górka, based on the Fox Footrest

Legs: solid ash wood with brass finishing

Internal structure: solid beech wood

Seat interior: zig zag springs, high resilience foam

Contract: norm passed EN 16139

COM: 1 pc = 2,4 x 1,4 m / 2+ pcs = 2,4 x 1,4 m

COL: 1 pc = 2 m2, from 2 pcs

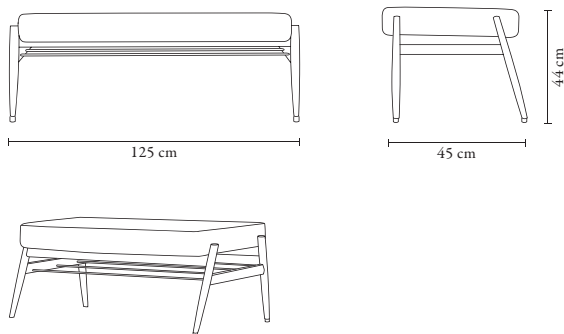

Width: 125 cm

Height: 44 cm

Depth: 45 cm

Packaging dimensions: 48 x 129 x 49 cm

Delivery: fully assembled furniture

Net weight: 9,6 kg

Gross weight: 12 kg

100% designed and manufactured in Poland

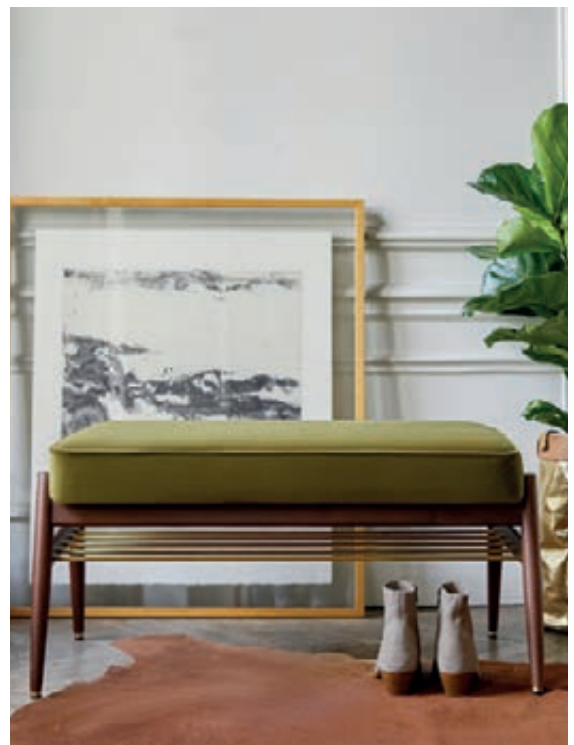

Velvet Coll. - Olive / Ash 05



Shine Velvet Coll. - Olive / Ash 05

Coffee tables

FOX ROUND COFFEE TABLE S & M

Story behind:

Designed by 366 Concept as a contemporary addition to the Fox Series. A hand-finished table of premium quality solid wood. Enjoy its timeless beauty and quality for years to come in your home. Light form will be a complete match for both minimalistic, modern and sublime interiors.

Design: 2017 by Agata Górka

Legs: solid ash wood with brass finishing

Top: solid ash wood

Contract: norm passed EN 16139

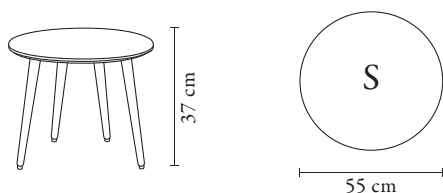

Width: 55 cm

Length: 55 cm

Height: 37 cm

Packaging dimensions: 42 x 59 x 59 cm

Net weight: 5,6 kg

Gross weight: 7 kg

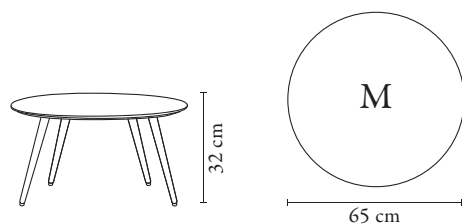

Width: 65 cm

Length: 65 cm

Height: 32 cm

Packaging dimensions: 36 x 69 x 69 cm

Delivery: fully assembled furniture

Net weight: 7,2 kg

Gross weight: 9 kg

100% designed and manufactured in Poland



Fox Round Coffee Table S / Ash 03



Fox Round Coffee Table M / Ash 03



Coffee tables

FOX ROUND COFFEE TABLE L28

Story behind:

Designed by 366 Concept as a contemporary addition to the Fox Series. A hand-finished table of premium quality solid wood. Enjoy its timeless beauty and quality for years to come in your home. Light form will be a complete match for both minimalistic, modern and sublime interiors.

Design: 2017 by Agata Górka

Legs: solid ash wood with brass finishing

Top: solid ash wood

Contract: norm passed EN 16139

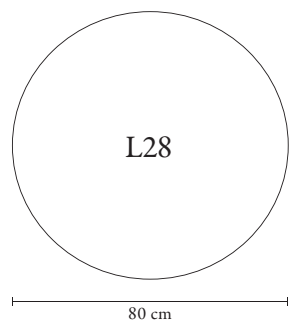
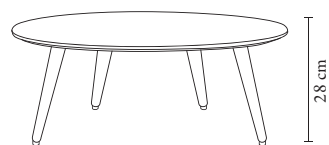

Width: 80 cm

Length: 80 cm

Height: 28 cm

Packaging dimensions: 32 x 84 x 84 cm

Delivery: fully assembled furniture

Net weight: 9,6 kg

Gross weight: 12 kg

100% designed and manufactured in Poland



Ash 03



Ash 03



Edvard Munch

MONTE CARLO
CAPRI

HELMUT NEWTON
COSTA SMERALDA

Passions Holiday
NOMAD DELUXE

HELMUT NEWTON

Coffee tables

FOX ROUND COFFEE TABLE L32

Story behind:

Designed by 366 Concept as a contemporary addition to the Fox Series. A hand-finished table of premium quality solid wood. Enjoy its timeless beauty and quality for years to come in your home. Light form will be a complete match for both minimalistic, modern and sublime interiors.

Design: 2017 by Agata Górka

Legs: solid ash wood with brass finishing

Top: solid ash wood

Contract: norm passed EN 16139

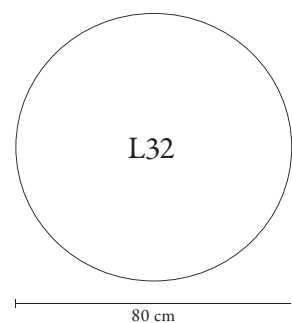
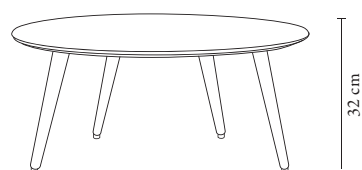

Width: 80 cm

Length: 80 cm

Height: 32 cm

Packaging dimensions: 40 x 84 x 84 cm

Delivery: fully assembled furniture

Net weight: 9,6 kg

Gross weight: 12 kg

100% designed and manufactured in Poland



Ash 03



Ash 03



Coffee tables

FOX ROUND SIDE COFFEE TABLE H

Story behind:

Designed by 366 Concept as a contemporary addition to the Fox Series. A hand-finished table of premium quality solid wood. Enjoy its timeless beauty and quality for years to come in your home. Light form will be a complete match for both minimalistic, modern and sublime interiors.

Design: 2017 by Agata Górka

Legs: solid ash wood with brass finishing

Top: solid ash wood

Contract: norm passed EN 16139

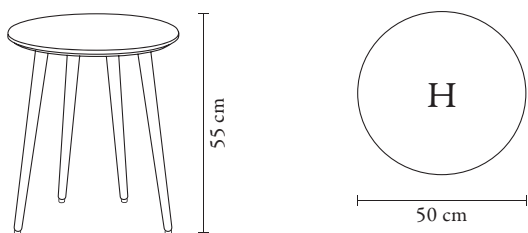

Width: 50 cm

Length: 50 cm

Height: 55 cm

Packaging dimensions: 59 x 54 x 54 cm

Delivery: fully assembled furniture

Net weight: 7,2 kg

Gross weight: 9 kg

100% designed and manufactured in Poland



Ash 03



Ash 03



Coffee tables

FOX SQUARE COFFEE TABLE S37

Story behind:

Solid ash wood and brass finish - an exclusive collection of coffee tables to match the Fox Lounge Chairs. The highest quality materials and the finest finish will delight any design connoisseur who is looking for a timeless addition to his interior. Available in 4 colors of ash wood and in 2 different heights: S37 and S55.

Design: 2017 by Agata Górka

Legs: solid ash wood with brass finishing

Top: solid ash wood

Contract: norm passed EN 16139

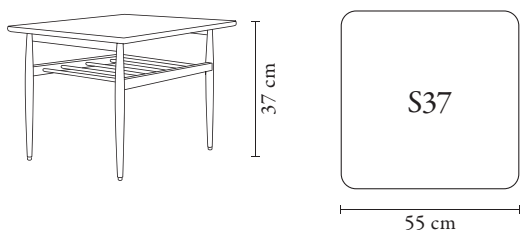

Width: 55 cm

Length: 55 cm

Height: 37 cm

Packaging dimensions: 59 x 59 x 59 cm

Delivery: fully assembled furniture

Net weight: 5,6 kg

Gross weight: 7 kg

100% designed and manufactured in Poland



Ash 03



Ash 03



Coffee tables

FOX SQUARE COFFEE TABLE S55

Story behind:

Solid ash wood and brass finish - an exclusive collection of coffee tables to match the Fox Lounge Chairs. The highest quality materials and the finest finish will delight any design connoisseur who is looking for a timeless addition to his interior. Available in 4 colors of ash wood and in 2 different heights: S37 and S55.

Design: 2017 by Agata Górka

Legs: solid ash wood with brass finishing

Top: solid ash wood

Contract: norm passed EN 16139

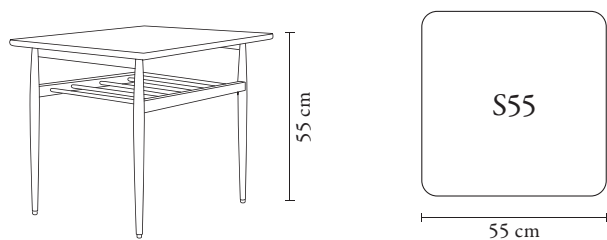

Width: 55 cm

Length: 55 cm

Height: 55 cm

Packaging dimensions: 59 x 59 x 59 cm

Delivery: fully assembled furniture

Net weight: 5,6 kg

Gross weight: 7 kg

100% designed and manufactured in Poland



Ash 03



Ash 03



Coffee tables

FOX RECTANGULAR COFFEE TABLE M37

Story behind:

The version lowered to a height of 37 cm fits ideally with the Fox Lounge Chair. Made of solid ash wood, finished with brass details. Available in 4 colors of ash wood and in 2 different heights: M37 and M55.

Design: 2017 by Agata Górka

Legs: solid ash wood with brass finishing

Top: solid ash wood

Contract: norm passed EN 16139

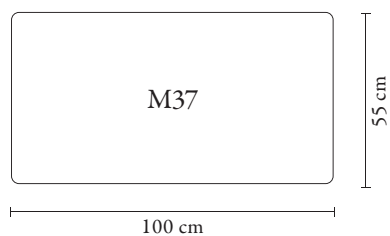
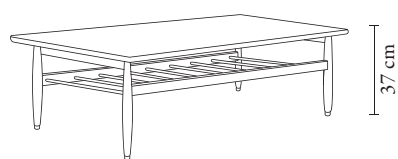

Width: 55 cm

Length: 100 cm

Height: 37 cm

Packaging dimensions: 40 x 104 x 59 cm

Delivery: fully assembled furniture

Net weight: 7,2 kg

Gross weight: 9 kg

100% designed and manufactured in Poland



Ash 03



Ash 03



Coffee tables

FOX RECTANGULAR COFFEE TABLE M55

Story behind:

This Rectangular Coffee Table is an ideal addition to the Fox Lounge Chair. Made of solid ash wood, finished with brass details. Available in 4 colors of ash wood and in 2 different heights: M37 and M55.

Design: 2017 by Agata Górká

Legs: solid ash wood with brass finishing

Top: solid ash wood

Contract: norm passed EN 16139

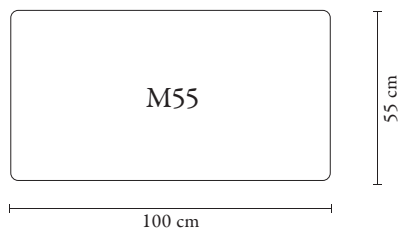

Width: 55 cm

Length: 100 cm

Height: 55 cm

Packaging dimensions: 59 x 104 x 59 cm

Delivery: fully assembled furniture

Net weight: 7,2 kg

Gross weight: 9 kg

100% designed and manufactured in Poland



Ash 03



Ash 03



Coffee tables

FOX TECKEL COFFEE TABLE

Story behind:

The brand-new Fox Teckel Coffee Table - the unique finish which harmonizes brilliantly with sofas and armchairs from the Fox Series. Wooden beams mounted under the countertop make this furniture not only exquisite, but also useful. These elements create an exceptional space for books, magazines and other personal pieces. Available in 4 colors of ash wood.

Original design: 1960s

Reedition: 2022 by 366 Concept

Legs: solid ash wood with brass finishing

Top: solid ash wood

Contract: norm passed EN 16139

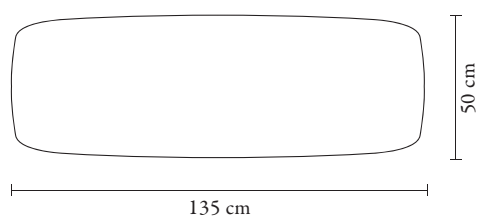
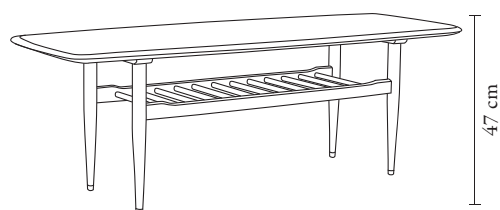

Width: 50 cm

Length: 135 cm

Height: 47 cm

Packaging dimensions: 140 x 60 x 60 cm

Delivery: fully assembled furniture

Net weight: 7,2 kg

Gross weight: 9 kg

100% designed and manufactured in Poland



Ash 03



Ash 03



Knudsen

Coffee tables

FOX MARBLE ROUND COFFEE TABLE

Story behind:

A unique work created by 366 Concept. The combination of Italian marble with wooden legs made of solid ash creates charm and integrity. The marble top is finished with a unique cutter, which distinguishes this table and makes it even more special. All types of our marble tables are available in 7 colors of stone, as well as in 2 sizes 60 cm and 105 cm. Legs are also available in 4 different colors.

Design: 2022 by Maciek Cypryk

Legs: solid ash wood with brass finishing

Top: marble

Colors of marble top:

- **Brown** - Emperador Dark
- **Bordeaux** - Rosso Levanto
- **White & Grey** - Breccia Vagli
- **Creme** - Diana Royal
- **Taupe** - Pietra Beige
- **White** - Bianco Carrara
- **Black** - Nero Marquina

Contract: norm passed EN 16139

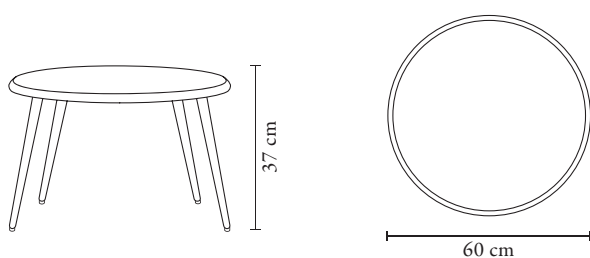

Width: 60 cm

Length: 60 cm

Height: 37 cm

Packaging dimensions: on pallet

Delivery: fully assembled furniture

Net weight: 15,2 kg

Gross weight: 19 kg

100% designed and manufactured in Poland



Marble Brown - Emperador Dark / Ash 03



Marble Brown - Emperador Dark / Ash 03



Coffee tables

FOX MARBLE LONG COFFEE TABLE

Story behind:

A unique work created by 366 Concept. The combination of Italian marble with wooden legs made of solid ash creates charm and integrity. The marble top is finished with a unique cutter, which distinguishes this table and makes it even more special. All types of our marble tables are available in 7 colors of stone, as well as in 2 sizes 60 cm and 105 cm. Legs are also available in 4 different colors.

Design: 2022 by Maciek Cypryk

Legs: solid ash wood with brass finishing

Top: marble

Colors of marble top:

- **Brown** - Emperador Dark
- **Bordeaux** - Rosso Levanto
- **White & Grey** - Breccia Vagli
- **Creme** - Diana Royal
- **Taupe** - Pietra Beige
- **White** - Bianco Carrara
- **Black** - Nero Marquina

Contract: norm passed EN 16139

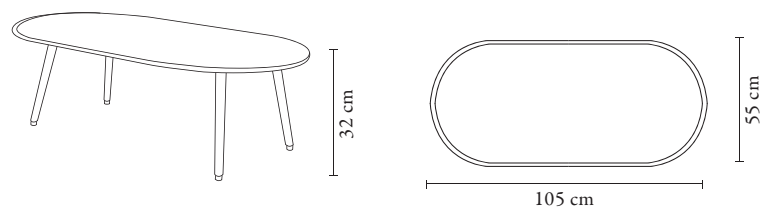

Width: 55 cm

Length: 105 cm

Height: 32 cm

Packaging dimensions: on pallet

Delivery: fully assembled furniture

Net weight: 21,6 kg

Gross weight: 27 kg

100% designed and manufactured in Poland



Marble Creme - Diana Royal



Marble White - Bianco Carrara / Ash 05



Coffee tables

366 TRIANGLE COFFEE TABLE S

Story behind:

You might think these tables were created in the 1960s, but in fact they were designed by 366 Concept.

The characteristic triangular top channels the spirit of the Mid-Century era. The tables are made exclusively of solid wood and hand finished. Available in 4 colors of oak wood and in 2 different sizes: S and M.

Design: 2014 by Maciek Cypryk

Legs: solid oak wood with brass finishing

Top: solid oak wood

Contract: norm passed EN 16139

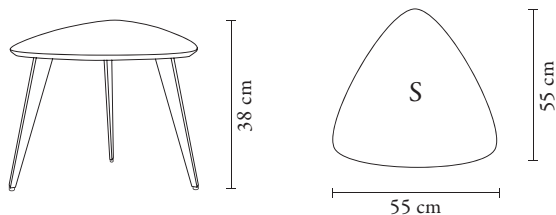

Width: 55 cm

Length: 55 cm

Height: 38 cm

Packaging dimensions: 42 x 59 x 59 cm

Delivery: fully assembled furniture

Net weight: 4,8 kg

Gross weight: 6 kg

100% designed and manufactured in Poland



366 Triangle Coffee Table S & M / Oak 03



Oak 03



Coffee tables

366 TRIANGLE COFFEE TABLE M

Story behind:

You might think these tables were created in the 1960s, but in fact they were designed by 366 Concept.

The characteristic triangular top channels the spirit of the Mid-Century era. The tables are made exclusively of solid wood and hand finished. Available in 4 colors of oak wood and in 2 different sizes: S and M.

Design: 2014 by Maciek Cypryk

Legs: solid oak wood with brass finishing

Top: solid oak wood

Contract: norm passed EN 16139



366 Triangle Coffee Table M & S / Oak 03

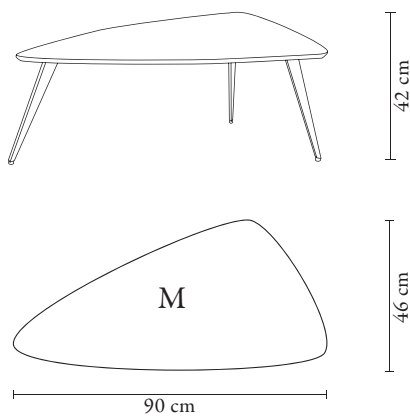

Width: 46 cm

Length: 90 cm

Height: 42 cm

Packaging dimensions: 46 x 94 x 50 cm

Delivery: fully assembled furniture

Net weight: 5,6 kg

Gross weight: 7 kg

100% designed and manufactured in Poland



Oak 03



Dining tables

DINING TABLE ELLIPSE & ROUND

Story behind:

Designed by 366 Concept for both homes and conference rooms. Dining Table offers the advantages of a round table without taking up too much space, hiding functionality under timeless aesthetics. It matches ideally with the 200-190 Chairs, both in upholstered and timber versions. The table is dedicated to those who prefer furniture with a classic design, but presented in a modern and refreshed form. It is available in Ellipse and Round form.

Design: Agata Górka, 2022

Material: solid oak wood

Contract: norm passed EN 16139



Table Ellipse / Oak 02

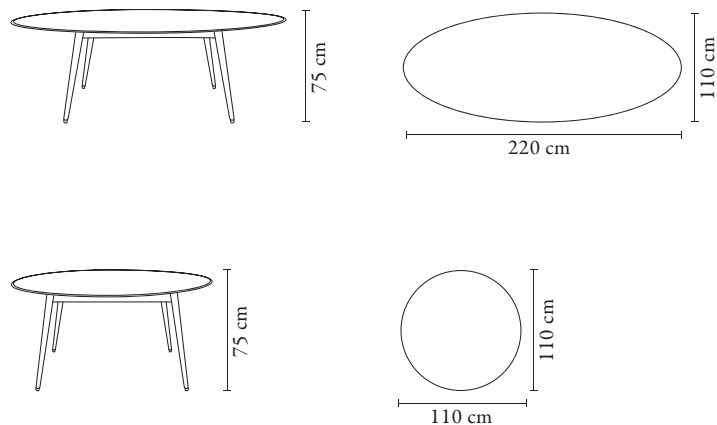

Table Ellipse:

Width: 110 cm

Length: 220 cm

Height: 75 cm

Table Round:

Width: 110 cm

Length: 110 cm

Height: 75 cm

Delivery: fully assembled furniture

Net weight - Table Ellipse: 50 kg

Net weight - Table Round: 25 kg

100% designed and manufactured in Poland



Table Ellipse / Oak 02



Desks

MINIMALIST DESK S60

Story behind:

Minimalist Desk designed by 366 Concept for your home office. Its slender, light form and distinctive clean lines create an impression of both modern and classic desks.

The Minimalist Desk, with its sublime V-shaped legs, looks admirably next to our 200-190 Chair. It is a stunning piece of furniture for all people who are looking for suitable solutions for a home-like office. The table top exists in 2 sizes: S60 - the narrow one and M80 - the wider one.

Design: 2022 by Maciek Cypryk

Top: oak veneer

Legs: solid oak wood

Contract: norm passed EN 16139



Oak 03

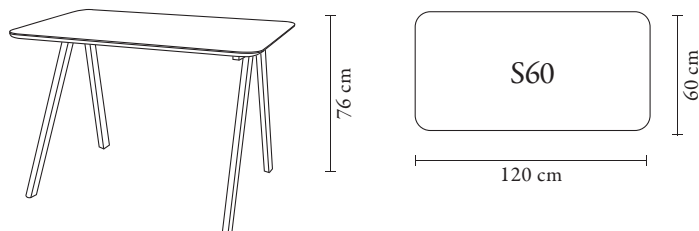

Width: 60 cm

Length: 120 cm

Height: 76 cm

Packaging dimensions: on pallet

Assembly: the desk requires only simple manual legs assembly

Net weight: 15 kg

100% designed and manufactured in Poland

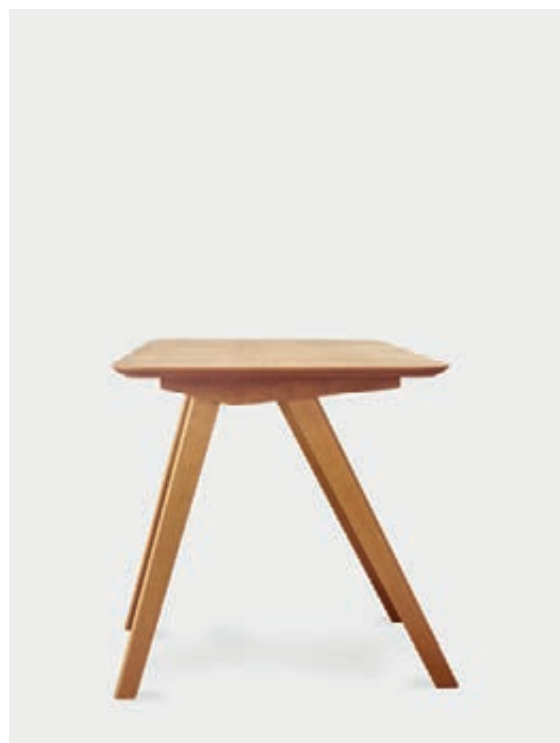

Oak 03



Desks

MINIMALIST DESK M80

Story behind:

Minimalist Desk designed by 366 Concept for your home office. Its slender, light form and distinctive clean lines create an impression of both modern and classic desks.

The Minimalist Desk, with its sublime V-shaped legs, looks admirably next to our 200-190 Chair. It is a stunning piece of furniture for all people who are looking for suitable solutions for a home-like office. The table top exists in 2 sizes: S60 - the narrow one and M80 - the wider one.

Design: 2022 by Maciek Cypryk

Top: oak veneer

Legs: solid oak wood

Contract: norm passed EN 16139

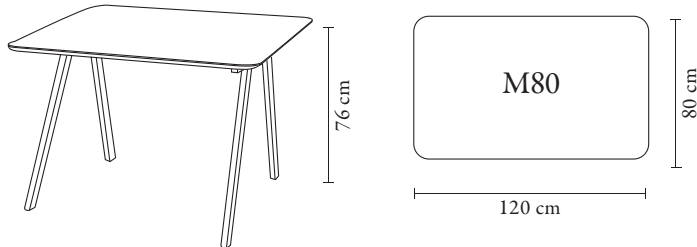

Width: 80cm

Length: 120 cm

Height: 76 cm

Packaging dimensions: on pallet

Assembly: the desk requires only simple manual legs assembly

Net weight: 20 kg

100% designed and manufactured in Poland



Oak 02

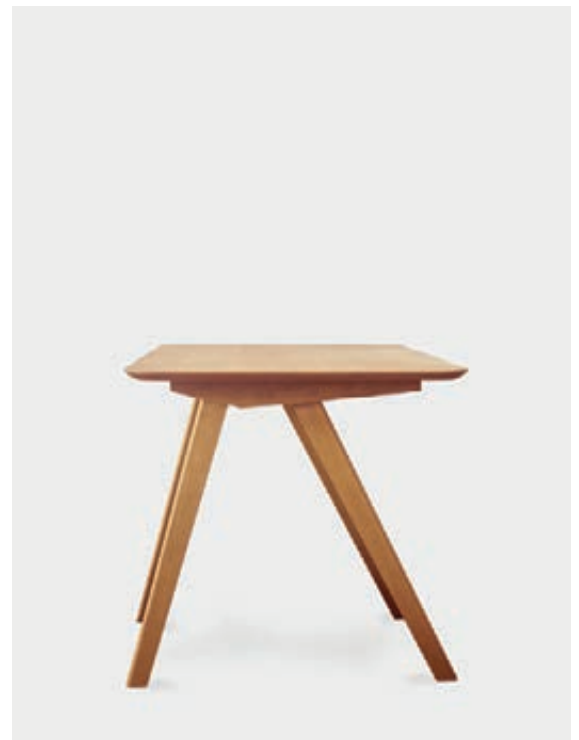

Oak 02



Sideboards

1050 PETITE SIDEBOARD

Story behind:

Reissue of the Iconic 1050 Petite Sideboard from the Sirius set designed in 1962 in Poland. 366 Concept has redefined it so you can enjoy unparalleled functionality with a new aesthetics perspective. The 1050 Petite Sideboard has 2 capacious shelves hidden behind sliding doors. This modern and timeless design can adapt to various styles and reflect the users personality and individuality at the same time. In our offer you will also find a Highboard and a Long Sideboard that together create a unique set of Mid-Century furniture. Made of solid oak wood and oak veneer. The 1050 Petite Sideboard is also available with glass sliding door.

Original design: 1962

Reedition: 2022 by 366 Concept

Legs: turned wooden legs with brass finishing

Contract: norm passed EN 16139

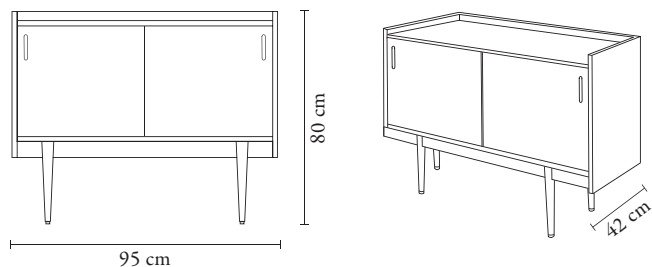

Width: 95 cm

Height: 80 cm

Depth: 42 cm

Packaging dimensions: on pallet

Assembly: The sideboard is delivered in a flat-pack and requires 2 people for its assembly. It's simple and only requires a hammer

Net weight: 18 kg

100% designed and manufactured in Poland

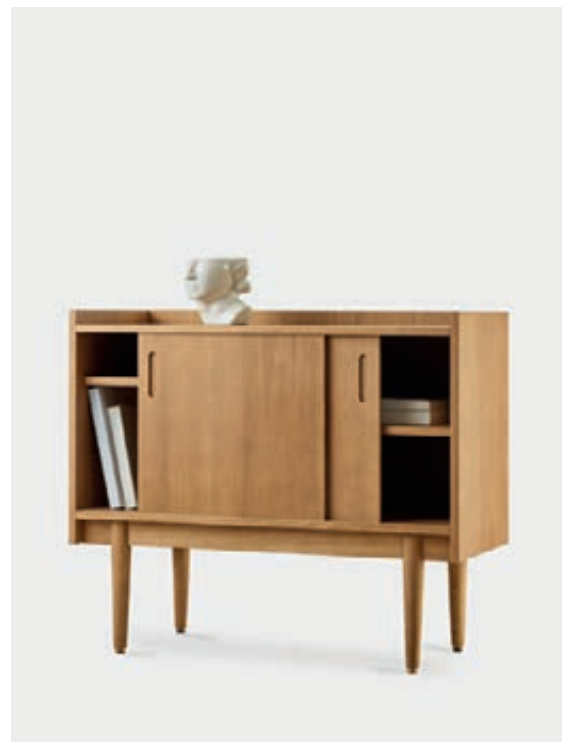

Oak 02

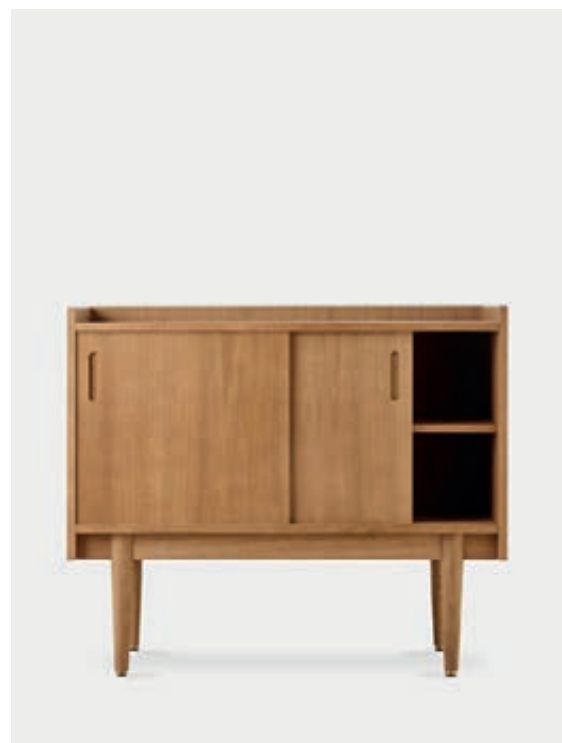

Oak 02



Sideboards

1050 PETITE SIDEBOARD WITH GLASS

Story behind:

Reissue of the Iconic 1050 Petite Sideboard from the Sirius set designed in 1962 in Poland. 366 Concept has redefined it so you can enjoy unparalleled functionality with a new aesthetics perspective. The 1050 Petite Sideboard has 2 capacious shelves hidden behind sliding doors. This modern and timeless design can adapt to various styles and reflect the users personality and individuality at the same time. In our offer you will also find a Highboard and a Long Sideboard that together create a unique set of Mid-Century furniture. Made of solid oak wood and oak veneer. The 1050 Petite Sideboard with Glass is also available with wooden sliding door.

Original design: 1962

Reedition: 2022 by 366 Concept

Legs: turned wooden legs with brass finishing

Contract: norm passed EN 16139

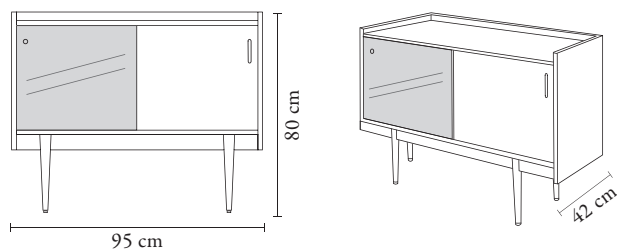

Width: 95 cm

Height: 80 cm

Depth: 42 cm

Packaging dimensions: on pallet

Assembly: The sideboard is delivered in a flat-pack and requires 2 people for its assembly. It's simple and only requires a hammer

Net weight: 18 kg

100% designed and manufactured in Poland



Oak 02

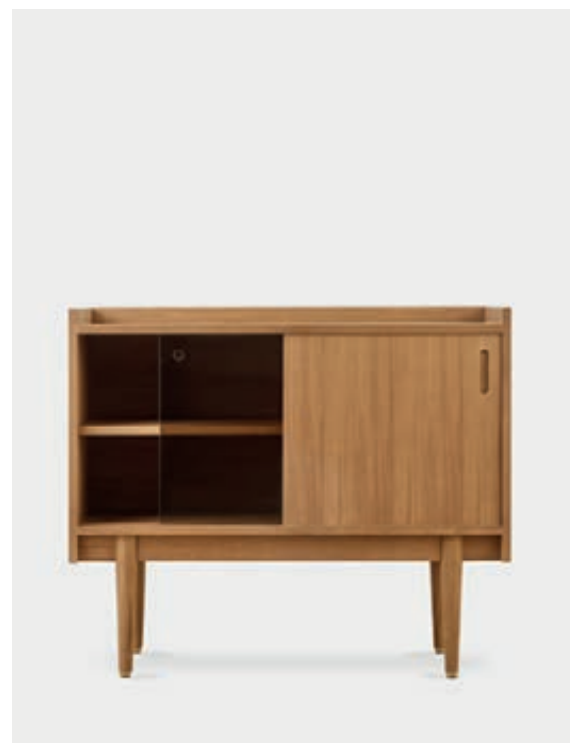

Oak 02



Sideboards

1050 LONG SIDEBOARD

Story behind:

Reissue of the Iconic 1050 Long Sideboard from the Sirius set designed in 1962 in Poland. 366 Concept has redefined it so you can enjoy unparalleled functionality with a new aesthetics perspective. The 1050 Long Sideboard has 3 drawers and 2 capacious shelves hidden behind sliding doors.

This modern and timeless design can adapt to various styles and reflect the users personality and individuality at the same time. In our offer you will also find a Highboard and a Petite Sideboard that together create a unique set of Mid-Century furniture. Made of solid oak wood and oak veneer.

Original design: 1962

Reedition: 2022 by 366 Concept

Legs: turned wooden legs with brass finishing

Contract: norm passed EN 16139

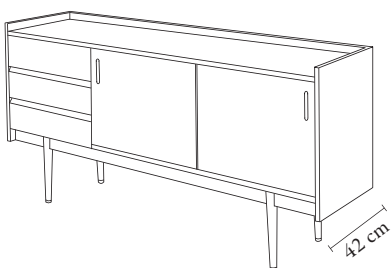
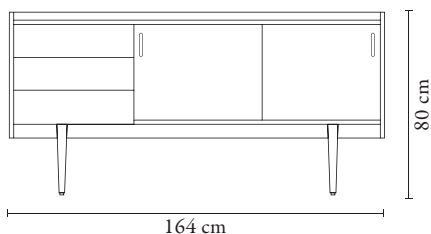

Width: 164 cm

Height: 80 cm

Depth: 42 cm

Packaging dimensions: on pallet

Assembly: The sideboard is delivered in a flat-pack and requires 2 people for its assembly. It's simple and only requires a hammer

Net weight: 40 kg

100% designed and manufactured in Poland



Oak 02



Oak 02



Sideboards

1050 HIGHBOARD

Story behind:

Reissue of the Iconic 1050 Highboard from the Sirius set designed in 1962 in Poland. 366 Concept has redefined it so you can enjoy unparalleled functionality with a new aesthetics perspective. The 1050 Highboard has 2 capacious shelves hidden behind sliding doors and 2 upper shelves one of which is behind a sublime brown glass cabinet. This modern and timeless design can adapt to various styles and reflect the users personality and individuality at the same time. In our offer you will also find a Long Sideboard and a Petite Sideboard that together create a unique set of Mid-Century furniture. Made of solid oak wood and oak veneer.

Original design: 1962

Reedition: 2022 by 366 Concept

Legs: turned wooden legs with brass finishing

Contract: norm passed EN 16139

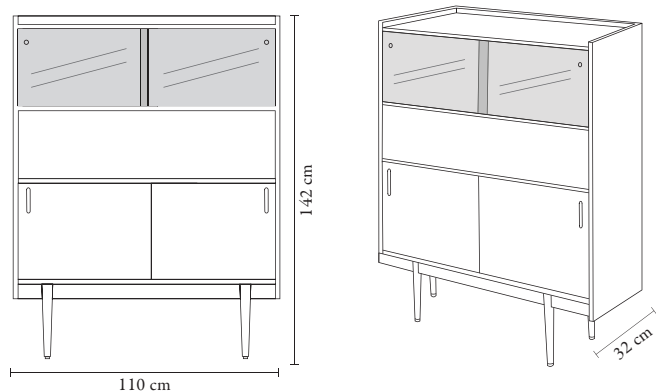

Width: 110 cm

Height: 142 cm

Depth: 32 cm

Packaging dimensions: on pallet

Assembly: The sideboard is delivered in a flat-pack and requires 2 people for its assembly. It's simple and only requires a hammer

Net weight: 35 kg

100% designed and manufactured in Poland



Oak 02



Oak 02



Cushions

RECTANGULAR CUSHION S & M

Story behind:

Eco-friendly cushions from 366 Concept are crafted using leftover upholstery fabrics from furniture production and filled with processed foam wastes. This guarantees the highest quality while minimizing the impact on the environment. The cushions are an ideal addition to armchairs and sofas, just choose a color that will complement the composition of your interior.

Design: 2014 by Agata Górka

Specifications:

- cushions are available in various fabric finishes
- the offer includes models with or without piping
- each cushion has a filling and a zipper
- different sizes and the possibility to mix different fabrics on the 2 sides of the cushion available upon request
- piping in different fabrics upon request

Dimensions S: 48 cm / 28 cm

Dimensions M: 58 cm / 38 cm

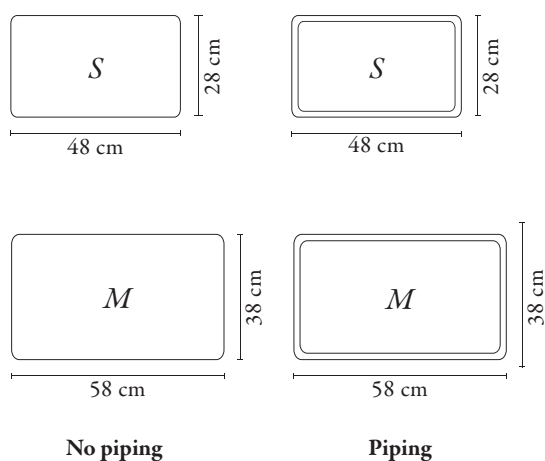

Rectangular Cushion S with piping / Wool Coll. - Mustard



Rectangular Cushion S with piping / Boucle Coll. - Mustard

100% designed and manufactured in Poland



Cushions

SQUARE CUSHION S & M

Story behind:

Eco-friendly cushions from 366 Concept are crafted using leftover upholstery fabrics from furniture production and filled with processed foam wastes. This guarantees the highest quality while minimizing the impact on the environment. The cushions are an ideal addition to armchairs and sofas, just choose a color that will complement the composition of your interior.

Design: 2014 by Agata Górka

Specifications:

- cushions are available in various fabric finishes
- the offer includes models with or without piping
- each cushion has a filling and a zipper
- different sizes and the possibility to mix different fabrics on the 2 sides of the cushion available upon request
- piping in different fabrics upon request

Dimensions S: 45 cm / 45 cm

Dimensions M: 55 cm / 55 cm

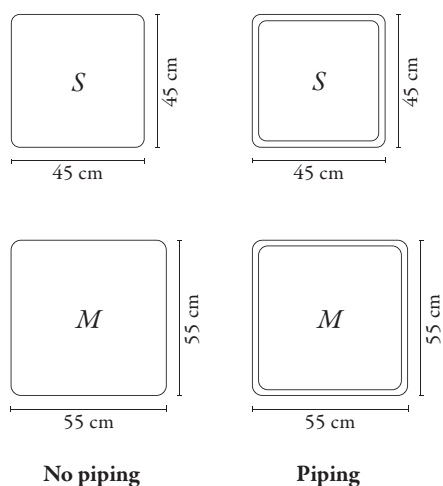

100% designed and manufactured in Poland



Square Cushion S with piping / Shine Velvet Coll. - Indigo



Square Cushion S with piping / Boucle Coll. - Denim



Cushions

CIRCLE CUSHION XS & S

Story behind:

Eco-friendly cushions from 366 Concept are crafted using leftover upholstery fabrics from furniture production and filled with processed foam wastes. This guarantees the highest quality while minimizing the impact on the environment. The cushions are an ideal addition to armchairs and sofas, just choose a color that will complement the composition of your interior.

Design: 2014 by Agata Górka

Specifications:

- cushions are available in various fabric finishes
- the offer includes models with or without piping
- each cushion has a filling and a zipper
- different sizes and the possibility to mix different fabrics on the 2 sides of the cushion available upon request
- piping in different fabrics upon request

Dimensions S: 30 cm / 30 cm

Dimensions M: 45 cm / 45 cm

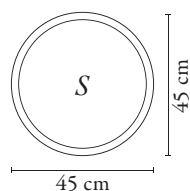
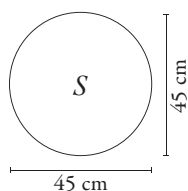
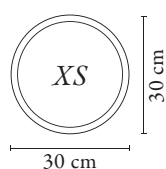
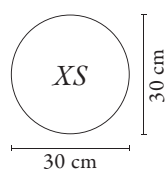

No piping

Piping



Circle Cushion S with piping / Boucle Coll. - Sierra



Circle Cushion S with piping / Boucle Coll. - Beige

100% designed and manufactured in Poland



Curtains

CURTAINS

Story behind:

The way we decorate our windows has a decisive influence on the general character and style of the arranged interior. Therefore, when deciding to buy curtains, we should take special care to ensure that they create a coherent whole with the other elements of the decor. Our range of fabrics offers you countless possibilities to communicate your style. Create your ideal curtains from over 100 exclusive, handpicked fabrics from around the world.

There are 2 types of curtains:

Type 1 - tape

Type 2 - rings

Unit: one linear meter, made to measure curtains



Curtain Type 1 / Shine Velvet Coll. - Mustard

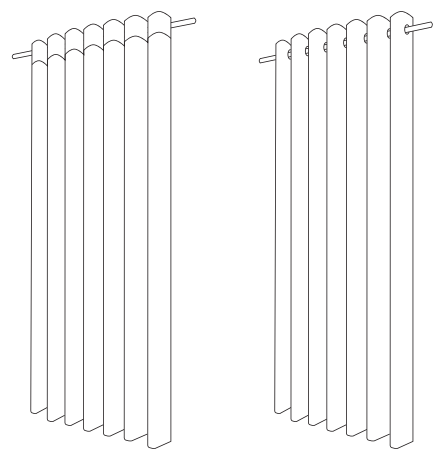

Type 1

Type 2

100% designed and manufactured in Poland



Velvet Coll. - Sierra



Finishes

FABRICS - 14 collections = 143 colors

VELVET Collection - 13 colors



Creme



Sand



Mustard



Sierra

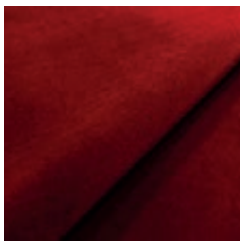

Red Brick



Olive

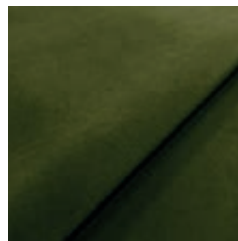

Turtle

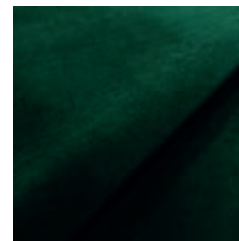

Bottle Green



Mint



Turquoise



Sky Blue

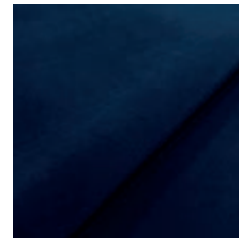

Indigo

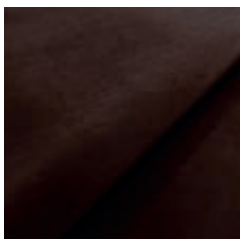

Chocolate

Story behind:

The VELVET collection is synonymous with refinement and softness. Velvet has delighted since its arrival in Europe, providing a royal feel. This highly tactile fabric, available in a soft color palette, fits a broad range of interiors, adding a touch of sophistication to any home. The fabric's special stain resistant coating makes it easy to clean.

Colors shades may slightly vary from dye-lot to dye-lot.

Fabric type: Velvet

Composition: 100% PES

Martindale abrasion: 100'000 cycles (cat. A)

Stain resistant: yes

Flame resistance: British BS 5852

Source 0 (Cigarette)

Wyzenbeek: 200,000 (cat. A)

Finishes

SHINE VELVET Collection - 13 colors



Creme



Taupe



Mustard



Sierra

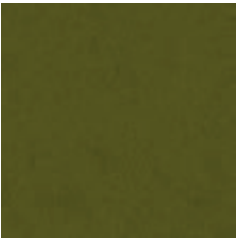

Olive



Emerald



Mauve

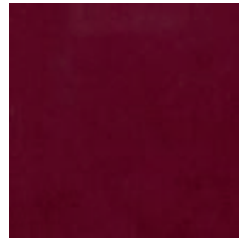

Bordeaux



Light Blue



Blue

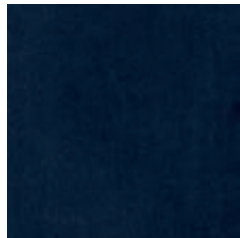

Indigo



Chocolate



Black

Story behind:

The SHINE VELVET collection is synonymous with softness and chic. Velvet has delighted since its arrival in Europe, providing a royal feel. Shine Velvet is highly tactile fabric, available in a soft color palette. It's very shiny, thanks to it beautifully harmonizes with light, changing the shade depending on the time of day.

Colors shades may slightly vary from dye-lot to dye-lot.

Fabric type: French Velvet

Composition: 100% PES

Martindale abrasion: 115'000 cycles (cat. A)

Stain resistant: yes

Flame resistance: BS EN 1021-1 Ignition Source 0 (Cigarette), BS EN 1021-2 Ignition Source 1 (Match)

Finishes

Wave Velvet Collection - 7 colors

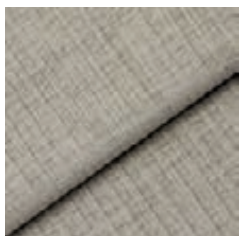

Creme



Mustard

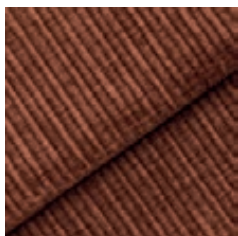

Sierra

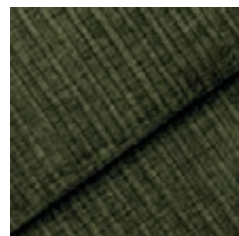

Olive

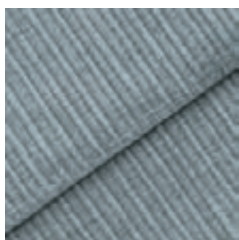

Light Blue

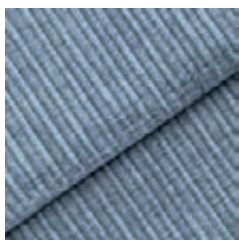

Jeans

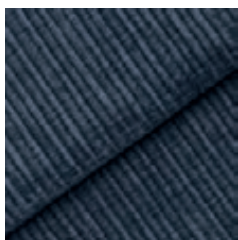

Denim

Story behind:

Pleasant to the touch chenille fabric with the effect of characteristic corduroy. This multifunctional high quality fabric will work well both as a furniture upholstery and as an accessory in the form of cushions.

It complements fabrics with a distinctive weave and velvets.

Technologies of easy cleaning and hindered absorption of spills will guarantee you comfort of use, clean and attractive furniture for years.

The Oeko Tex certificate assures us that the fabric is allergen-free and completely safe.

Fabric type: Velvet

Composition: 47% PES, 45% PA, 8% VI

Martindale abrasion: 35'000 cycles (cat. A)

Stain resistant: yes

Flame resistance: Cigarette Test

Finishes

CORD Collection - 9 colors

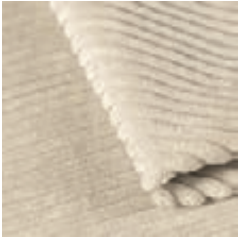

Creme



Taupe

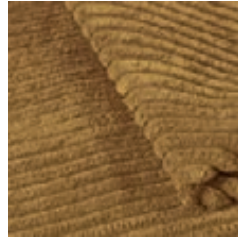

Mustard

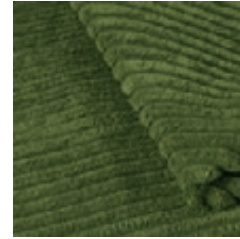

Grass

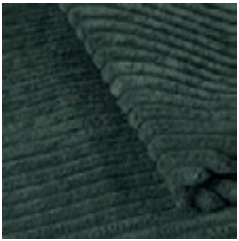

Bottle Green



Mint



Indigo

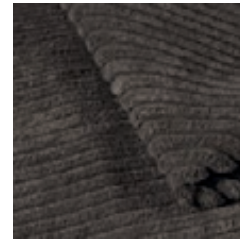

Cappuccino

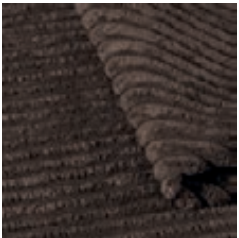

Cacao

Story behind:

CORD fabric is very soft and pleasant to the touch, and at the same time an extremely strong and durable velor fabric with an interesting, albeit classic texture. Exquisite as a cover of the whole piece of furniture, a single element or as a material for sublime and stylish accessories.

Fabric type: Velvet

Composition: 88% PES, 12 % PA

Martindale abrasion: 100'000 cycles (cat. A)

Colors shades may slightly vary from dye-lot to dye-lot.

Finishes

BOUCLE Collection - 17 colors



Snow



Creme



Camel



Beige

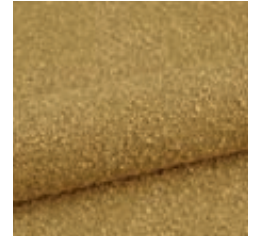

Mustard



Ginger



Sierra



Powder Pink

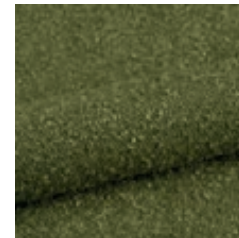

Olive

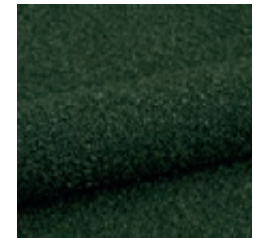

Bottle Green

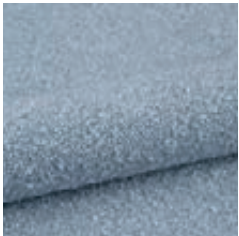

Blue

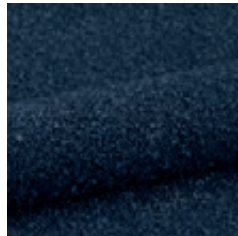

Denim



Indigo

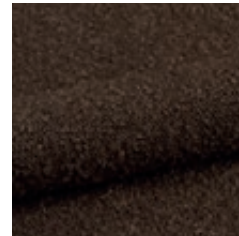

Chocolate

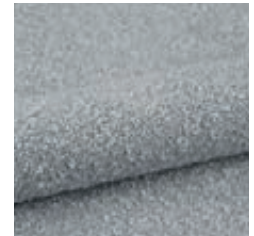

Mouse Grey



Graphite

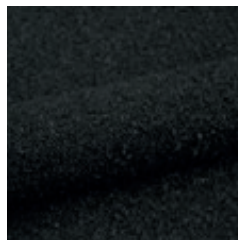

Black

Story behind:

BOUCLE fabric is a material woven from yarns with an irregular structure, with knotty lugs that can create a cozy atmosphere. In this irregularity lies all the charm of boucle fabric - its surface is soft, warm and pleasant to the touch. It is coated with molecules and a hydrophobic coating that protects fabric from dirt and absorption of liquids. It also meets high quality standards Oeko-Tex Standard 100 certificate.

Colors shades may slightly vary from dye-lot to dye-lot.

Fabric type: Loop

Composition: 93% PES, 6% ACR, 1% COT

Martindale abrasion: > 100'000 cycles (cat. A)

Stain resistant: yes

Flame resistance: Cigarette Test PN-EN

1021-1:2014-12

Finishes

COCO Collection - 13 colors



Snow



Creme

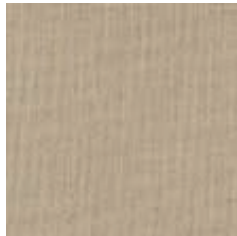

Sand

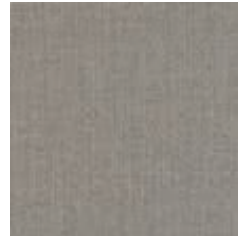

Beige

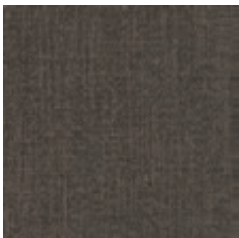

Taupe



Mustard



Olive

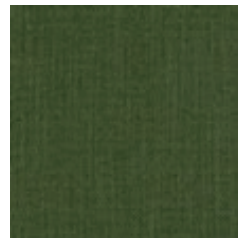

Bottle Green



Light Blue



Jeans



Indigo

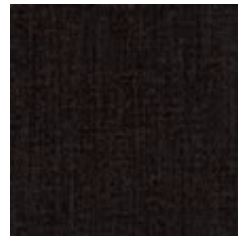

Chocolate

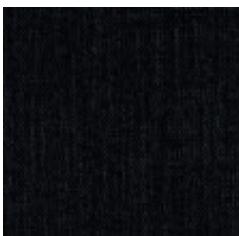

Black

Story behind:

Fabrics from the COCO collection are typical Scandinavian thick weave. The 366 Concept furniture in beiges and greys from this collection will be a complete match for both minimalistic, modern and sublime interiors.

Colors shades may slightly vary from dye-lot to dye-lot.

Fabric type: Woven

Composition: 84% PES, 16% AC

Martindale abrasion: 30'000 cycles (cat. A)

Flame resistance: BS EN 1021-1 Ignition Source 0 (Cigarette), BS EN 1021-2 Ignition Source 1 (Match)

Finishes

MARBLE Collection - 8 colors

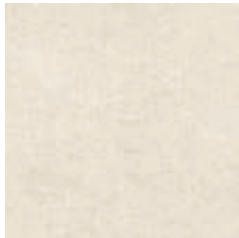

White



Beige



Mustard

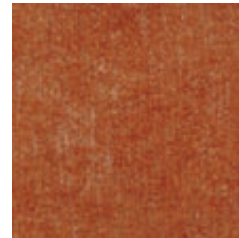

Orange



Light Blue

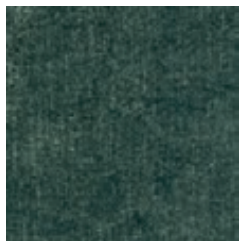

Bottle Green



Indigo



Black

Story behind:

Fabrics from the MARBLE collection are characterized by a unique structure, reminiscent of natural marble. There are no two identical pieces of this fabric. Thanks to it your furniture will be absolutely unique.

Fabric type: Chenille

Composition: 87% PES, 13% Rayon

Martindale abrasion: 45'000 cycles (cat. B)

Flame resistance: BS EN 1021-1 Ignition Source 0 (Cigarette), BS EN 1021-2 Ignition Source 1 (Match)

Colors shades may slightly vary from dye-lot to dye-lot.

Finishes

WOOL Collection - 12 colors

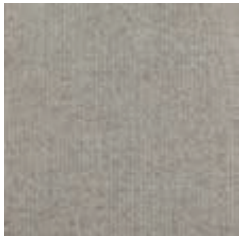

Sand

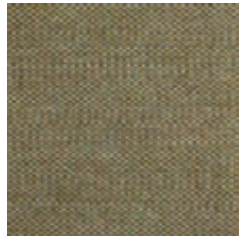

Light Mustard



Mustard



Orange Beige



Olive

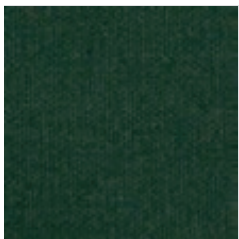

Bottle Green



White Blue



Grey Blue



Turquoise



Jeans

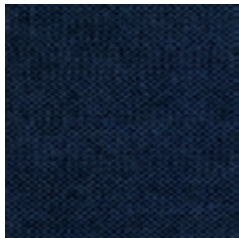

Blue



Grey Black

Story behind:

The WOOL collection uses new-generation fabrics made from natural materials. Weaving long, smooth wild flax fibre between the wool creates a stunning two-tone color inspired by precious stones. The addition of flax makes wool fabrics less flammable, which means that they are exquisite for commercial interiors, such as hotels or restaurants.

Fabric type: Woven

Composition: 75% VIRGIN WOOL, 25% FLAX

Martindale abrasion: > 50'000 cycles (cat. A)

Flame resistance: BS 7176 Low Hazard, NFPA

260 + UFAC Class 1

Colors shades may slightly vary from dye-lot to dye-lot.

Finishes

TEDDY Collection - 4 colors



Creme



Beige



Mustard



Cappuccino

Story behind:

The fabrics from one of the most fashionable TEDDY collection are characterized by delicate structure that resembles soft plush.

What distinguishes them is knotted weave, high grammage and resistance to abrasion. Teddy looks prominent against the background of walls made of natural wood, raw brick, concrete or stone. Exceptionally soft texture and toned-down color range are exquisite complement for rooms in boho style, as well as Scandinavian, where it adds a bit of warmth, coziness and lightness.

Fabric type: Loop

Composition: 100% PES

Martindale abrasion: > 50 000 cycles (cat. A)

Flame resistance: BS EN 1021-1 Ignition Source 0 (Cigarette) , BS EN 1021-2 Ignition Source 1 (Match)

Colors shades may slightly vary from dye-lot to dye-lot.

Finishes

BRAID Collection - 10 colors



Crema



Beige



Light Brown



Mustard

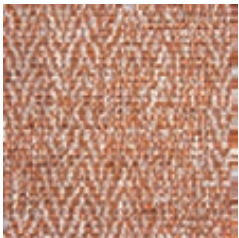

Sierra

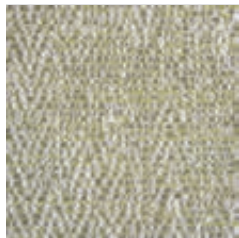

Olive

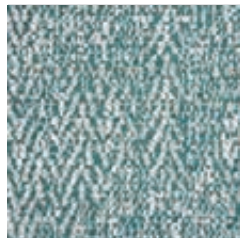

Emerald



Indigo

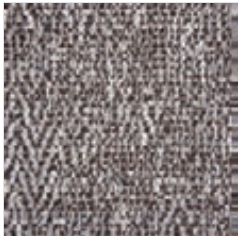

Brown

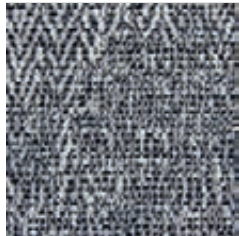

Black

Story behind:

The BRAID fabric has been appreciated by the greatest designers and interior architects. The colors from the collection emphasize the thick woven structure of the material that is pleasant and soft to the touch. Each color has an admixture of white which makes the fabric even lighter and warmer. Its thick braid weave makes furniture very cozy, and combined with the natural color of the wood, it will become an idyllic addition in your homes. The special finish of the fabrics protects them from the rapid seepage of liquids, or even effectively blocks the infiltration of dirt into the fabric.

Fabric type: Braid

Composition: 60% COT, 14% VI, 9% AC, 7% PES, 6% LI, 4% Other

Martindale abrasion: 20'000 cycles (cat. A)

Fire resistance: BS 5852 Part I – Cigarette Test, EN 1021-1 – Cigarette Test, CA Tech. Bull. 117:2013 / NFPA 260

Colors shades may slightly vary from dye-lot to dye-lot.

Finishes

MONDRIAN Collection - 1 color



Mondrian

Story behind:

Dive into the artistic expression of uncompromising interiors. Mondrian collection is a fabric featuring an embroidered geometric pattern that is suitable for armchairs, chairs, curtains and small accessories such as pillows. The fabric is also Oeko-tex 100 certified so that you can be confident that it doesn't contain any materials known to be hazardous to human health.

Fabric type: Embroidery

Composition: 82% Polyester, 18% Cotton

Martindale abrasion: 25'000 cycles (cat. A)

Colors' shades may slightly vary from dye-lot to dye-lot.

Finishes

COFFEE Collection - 4 colors



Snow



Beige



Mustard



Olive

Story behind:

The Coffee Collection amazes with timeless appeal of the art of embroidery but reimagined for modern tastes and sensibilities.

A striking, modern, and dynamic textile design. This geometric pattern features a novelty tufted technique that really lifts it up.

Fabric type: Embroidery

Composition: 81% Polyester, 19% Cotton

Martindale abrasion: 25'000 cycles (cat. A)

Wyzenbeek: 100,000

Colors' shades may slightly vary from dye-lot to dye-lot.

Finishes

CASAMANCE Collection - 25 colors



Amalfi Ocre Orange



Amalfi Vert Jaune



Amalfi Vert Orange



Amorgos Ficelle

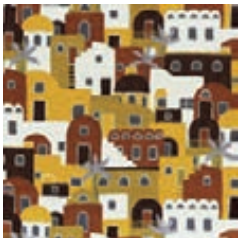

Amorgos Terre



Aveiro Beige Celadon

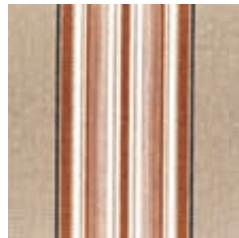

Aveiro Beige Orange Brulee



Aveiro Ocre

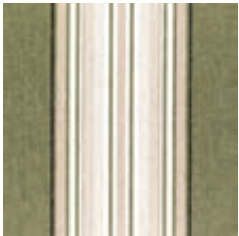

Aveiro Olive



Costa Nova Bleu



Costa Nova Corail

Story behind:

Casamance brings contemporary interiors to life by creating classics of the future. Their collections are distinguished by carefully developed color palettes, diverse motifs and high-quality materials. The alchemy of colors dresses up a wide cross-section of architectural spaces, adding French elegance and originality to them at the same time.

Colors' shades may slightly vary from dye-lot to dye-lot.

Finishes

CASAMANCE Collection - 25 colors



Djinn Kaki Celadon



Djinn Noir de lune



Djinn Roux Marine



Evora Beige



Evora Ocre



Evora Olive



Evora Orange Brulee

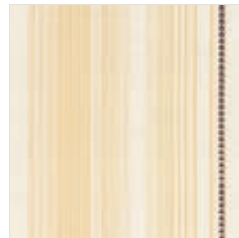

Ravello Mimosa



Ravello Noir



Ravello Vert

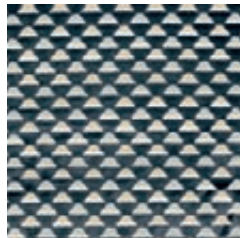

Uroko Carbone



Uroko Moutarde



Uroko Roux

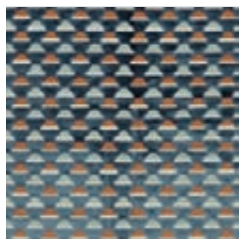

Uroko Topaze

Story behind:

Casamance brings contemporary interiors to life by creating classics of the future. Their collections are distinguished by carefully developed color palettes, diverse motifs and high-quality materials. The alchemy of colors dresses up a wide cross-section of architectural spaces, adding French elegance and originality to them at the same time.

Colors' shades may slightly vary from dye-lot to dye-lot.

Finishes

NATURAL LEATHER Collection - 7 colors



Mustard



Cognac



Brown

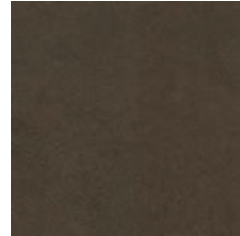

Chocolate



Olive

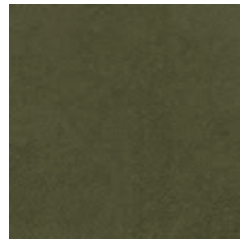

Bottle Green

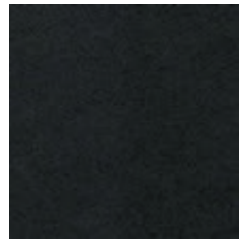

Black

Story behind:

NATURAL LEATHER is one of the oldest and most exclusive materials used by humans. Thanks to its elegance, it has the ability to transform products into durable, iconic and personalized objects. In our offer you will find a selection of the most exquisite colors that will make your interior chic and unique.

Fabric type: Natural Leather

Composition: 100% Natural Leather

Colors shades may slightly vary from dye-lot to dye-lot.

Finishes

WOOD - 2 types

Ash Wood - 4 colors



Natural 02

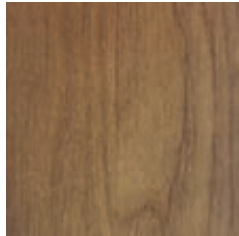

Caramel 03

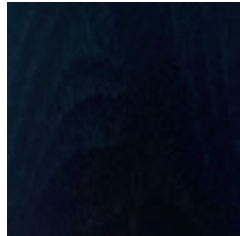

Black 04

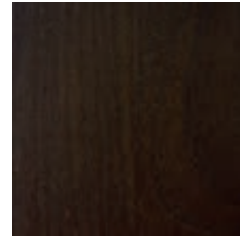

Brown 05

Story behind:

Ash is a noble wood with special properties. It is used especially when elasticity and strength are required. Ash is also valued due to its structure that is characterized by a marbled pattern. It can also be recognized by its clearly visible annual rings that indicate the highest quality of the wood.

For this reason, it is often used in the production of furniture.

Selected to series:

- Fox
- 200-190
- 200-125 VAR

Oak Wood - 4 colors



Natural 02

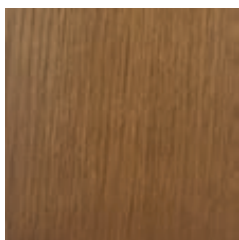

Caramel 03



Black 04

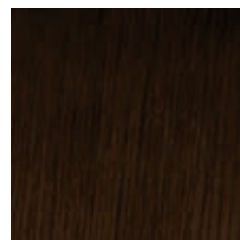

Brown 05

Story behind:

Oak wood is one of the highest quality woods with beautiful decorative surface. The grain has a uniform structure, in which the annual rings are visible. Therefore the oak wood is preferred in the construction of noble solid wood furniture. It is prized in furniture making because of its durability, workability and natural beauty.

Selected to series:

- 366
- Bunny
- Dining tables
- Desks
- Sideboards
- Stefan

Finishes

METAL - 2 types

Story behind:

366 Concept selects the most refined metals, steel and brass in matt finish. The metals have a galvanic finish and are coated with a thin layer of a more noble metal. This makes 366 Concept furniture even more captivating.

Black Matt



366 Series

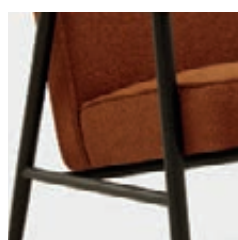

Fox Series

Story behind:

Our Black Matt finish looks stunning on the 366 Metal and Fox Metal Series.

They allow you to maintain a natural, classic look, thanks to which they will enrich any interior.

The Black Matt finish fits splendidly with our wooden armrests, which is why this color has been the most attractive finish in the metal series for many years.

Brass Matt

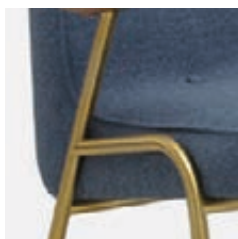

366 Series

Story behind:

Our Brass Matt is a great finish for people who want to feel a subtle refinement effect.

The Brass Matt finish is a subdued and unique color that splendidly harmonizes with the cream upholstery. In combination with wooden armrests, it creates an extraordinary piece.

It is both sophisticated and subtle finish for a unique interior. Selected only to 366 Metal Series.

Finishes

MARBLE - 7 colors

Brown - Emperador Dark

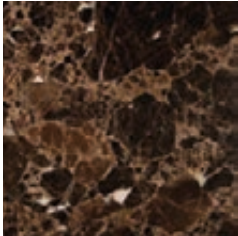

Story behind:

Emperador Dark is highly valued by designers and interior architects due to its distinctive pattern with rich veining and strong dark color. A brown, cream-beige natural stone clearly captures the unique southern warmth. It goes very well with natural wood.

Bordeaux - Rosso Levanto

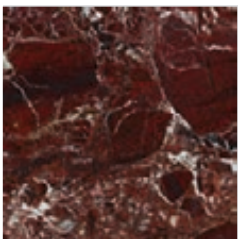

Story behind:

A striking, rich deep maroon stone with contrasting white veins that adds a natural texture. Rosso Levanto marble's uniqueness is a bold addition to any design that enriches your interior with the appearance of unmitigated refinement. This marble effortlessly blends red, brown, maroon, black and white tones into a natural masterpiece that creates an sophisticated aura that engulfs any space.

White & Grey - Breccia Vagli

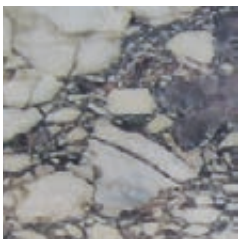

Story behind:

Breccia Vagli is a classic marble with plenty of character. The depth of color is apparent in the polished finish. It resembles ice sheets floating in a deep sea that reflects the beauty of nature. Breccia Vagli marble is distinguished by the striking contrast of white and grey. The opulent glamour of this Italian marble has inspired many names in design world.

Creme - Diana Royal

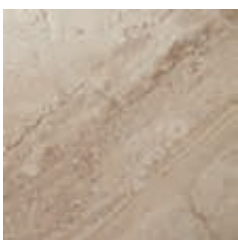

Story behind:

A stunning blend of linen and light grey-cream tones. Diana Royal is a type of light and white coloured marble which uncover your meaning of softness and beauty. Its light beige color makes it easily fit in every architectural context. Also, since its color is really light and bright, it makes any interior look more spacious and gives it a desired calm and a fresh look.

Finishes

Taupe - Pietra Beige

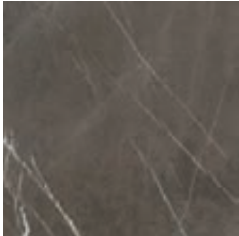

Story behind:

Beautiful, unusual taupe, color with various shades and white-taupe veins. The exclusive, unique Pietra Beige color and contrasting shades of white make it a noble and modern material. Taupe is an exclusive stone that includes tiles of various shades. Bright lines may appear on each table top. This feature is typical of natural stone, especially marbles with rich veins.

White - Bianco Carrara

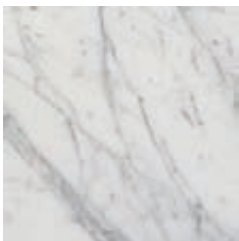

Story behind:

Bianco Carrara is a beautiful Italian marble with unique veins that fits into any space and harmonizes very well with wooden elements. This Italian marble has a light background - white, grey and fine veins that are unevenly scattered on each top. Bianco Carrara is an exquisite addition to any interior.

Black - Nero Marquina

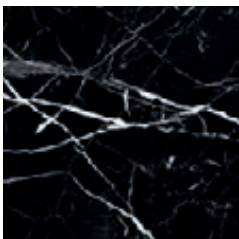

Story behind:

Nero Marquina - an extraordinary marble straight from Spain. Nero Marquina is a unique, beautiful, classic marble that looks great in a set and also fits splendidly with the Pietra Beige and the Bianco Carrara tables. This marble will enrich any space with their deep and sublime blackness. There are noticeable white veins that add a beauty stone and at the same time are a very characteristic element of this stone.

Furniture series

366



366
Armchair



366
Rocking Chair

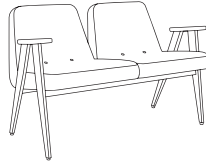

366
2-Seater

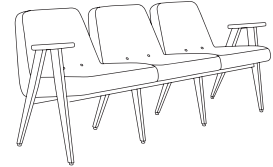

366
3-Seater

366 JUNIOR



366 Junior
Armchair



366 Junior
Rocking Chair

366 METAL



366 Metal
Armchair



366 Metal
Club Chair

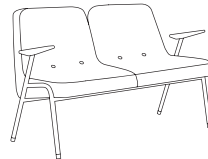

366 Metal
2-Seater

BUNNY



Bunny
Armchair

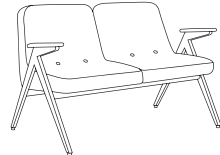

Bunny
2-Seater

Furniture series

FOX

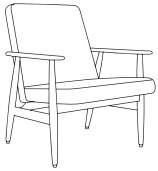

Fox
Lounge Chair



Fox
Rocking Chair

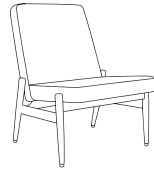

Fox
Club Chair



Set - Fox Lounge Chair &
Footrest

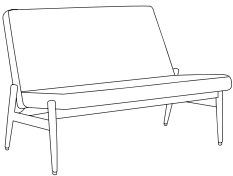

Fox
Club Sofa

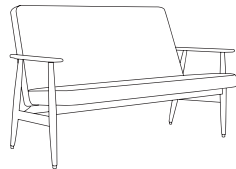

Fox
Sofa

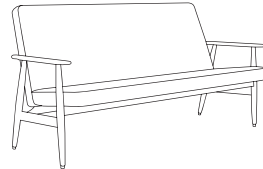

Fox
Long Sofa

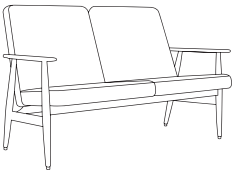

Fox
2-Seater

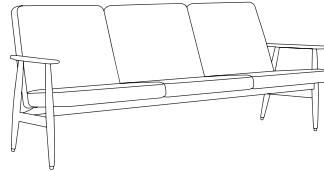

Fox
3-Seater

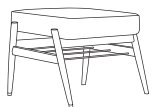

Fox
Footrest



Fox
Bench 90

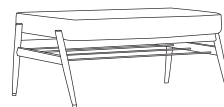

Fox
Bench 125

FOX METAL



Fox Metal
Lounge Chair

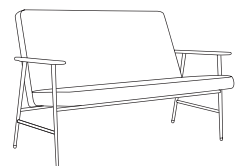

Fox Metal
Sofa

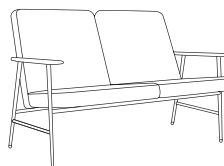

Fox Metal
2-Seater



Set - Fox Lounge Chair
& Side Coffee Table H

Furniture series

STEFAN

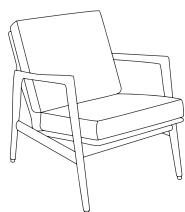

Stefan
Lounge Chair

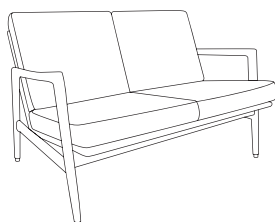

Stefan
2-Seater

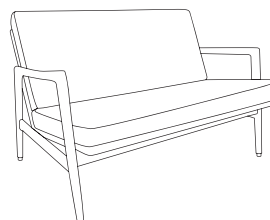

Stefan
Sofa

200-190



200-190
Chair



200-190
Chair Stackable



200-190
Bar Stool S65



200-190
Bar Stool M75



200-190
Bar Stool Basic S65



200-190
Bar Stool Basic M75



200-190
Bench

200-190 MIX



200-190
Chair Mix



200-190
Bar Stool Mix S65



200-190
Bar Stool Mix M75

Furniture series

200-190 TIMBER



200-190
Chair Timber



200-190
Bar Stool Timber
S65



200-190
Bar Stool Timber
M75



200-190
Bar Stool Timber
Basic S65



200-190
Bar Stool Timber
Basic M75

200-125 VAR



200-125
VAR Chair

366 COFFEE TABLES



366 Triangle
Coffee Table S

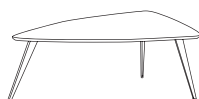

366 Triangle
Coffee Table M



Set - 366 Triangle
Coffee Table S & M

Furniture series

FOX COFFEE TABLES



Fox Round
Coffee Table S



Fox Round Side
Coffee Table H



Fox Round
Coffee Table M



Fox Round
Coffee Table L28



Fox Round
Coffee Table L32



Fox Square
Coffee Table S37



Fox Square
Coffee Table S55



Fox Rectangular
Coffee Table M37



Fox Rectangular
Coffee Table M55

FOX COFFEE TABLES

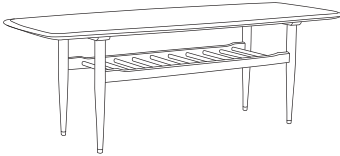

Fox Teckel
Coffee Table

MARBLE TABLES



Fox Marble Round
Coffee Table



Fox Marble Long
Coffee Table

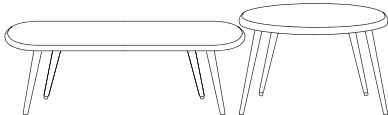

Set - Fox Marble Long
& Round Coffee Tables

Furniture series

DINING TABLES

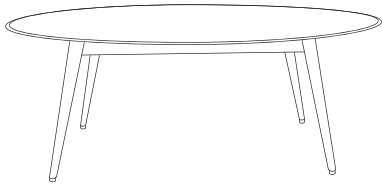

Dining Table
Ellipse

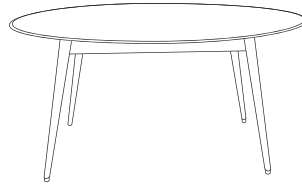

Dining Table
Round

DESKS



Minimalist
Desk S60



Minimalist
Desk M80

1050 SIDEBOARDS

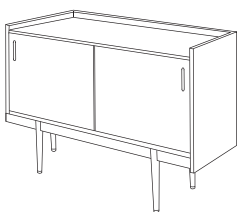

1050 Petite
Sideboard

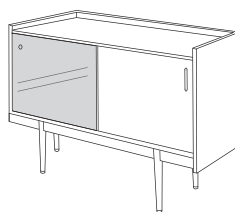

1050 Petite
Sideboard with Glass

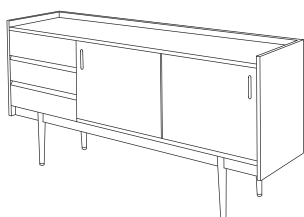

1050 Long
Sideboard

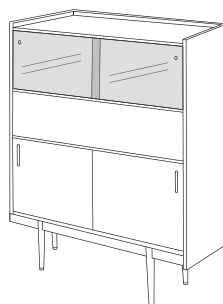

1050
Highboard

Furniture series

CUSHIONS

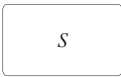

Rectangular
Cushion S

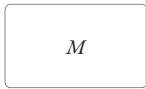

Rectangular
Cushion M

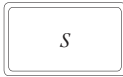

Rectangular Cushion S
with piping

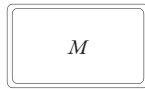

Rectangular Cushion M
with piping

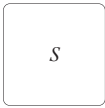

Square
Cushion S

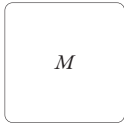

Square
Cushion M



Square Cushion S
with piping



Square Cushion M
with piping



Circle
Cushion XS

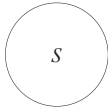

Circle
Cushion S



Circle Cushion XS
with piping

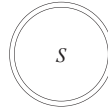

Circle Cushion S
with piping

CURTAINS

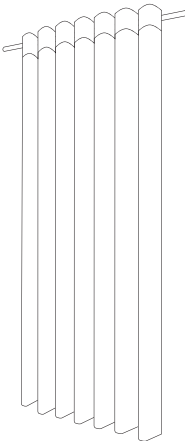

Type 1
Tape

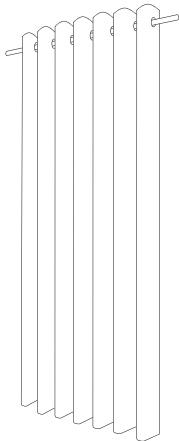

Type 2
Rings

Contacts

B2C

E hello@366concept.com

M + 48 570 480 190

B2B & ARCHITECTS

E business@366concept.com

M + 48 533 326 366

OFFICE & SHOWROOM

E hello@366concept.com

M + 48 570 480 190

W 366concept.com

A Bagatela 10/5, 00-585 Warsaw, Poland

PRESS

E pr@366concept.com

MARKETING

E marketing@366concept.com

FOUNDERS

Agata Górka

E agata@366concept.com

M + 48 502 251 616

Maciek Cypryk

E maciek@366concept.com

ART DIRECTION

Agata Górka - 366 Concept

PICTURE CREDITS

366 Concept - Furniture Icons

Rose & Grey: p. 57, p. 63

If we have inadvertently used material without acknowledgement, we will correct the omission immediately upon notification.

No part of this catalog may be reproduced without prior written permission from 366 Concept - Furniture Icons.

© 2023, 366 Concept - Furniture Icons. All rights reserved.

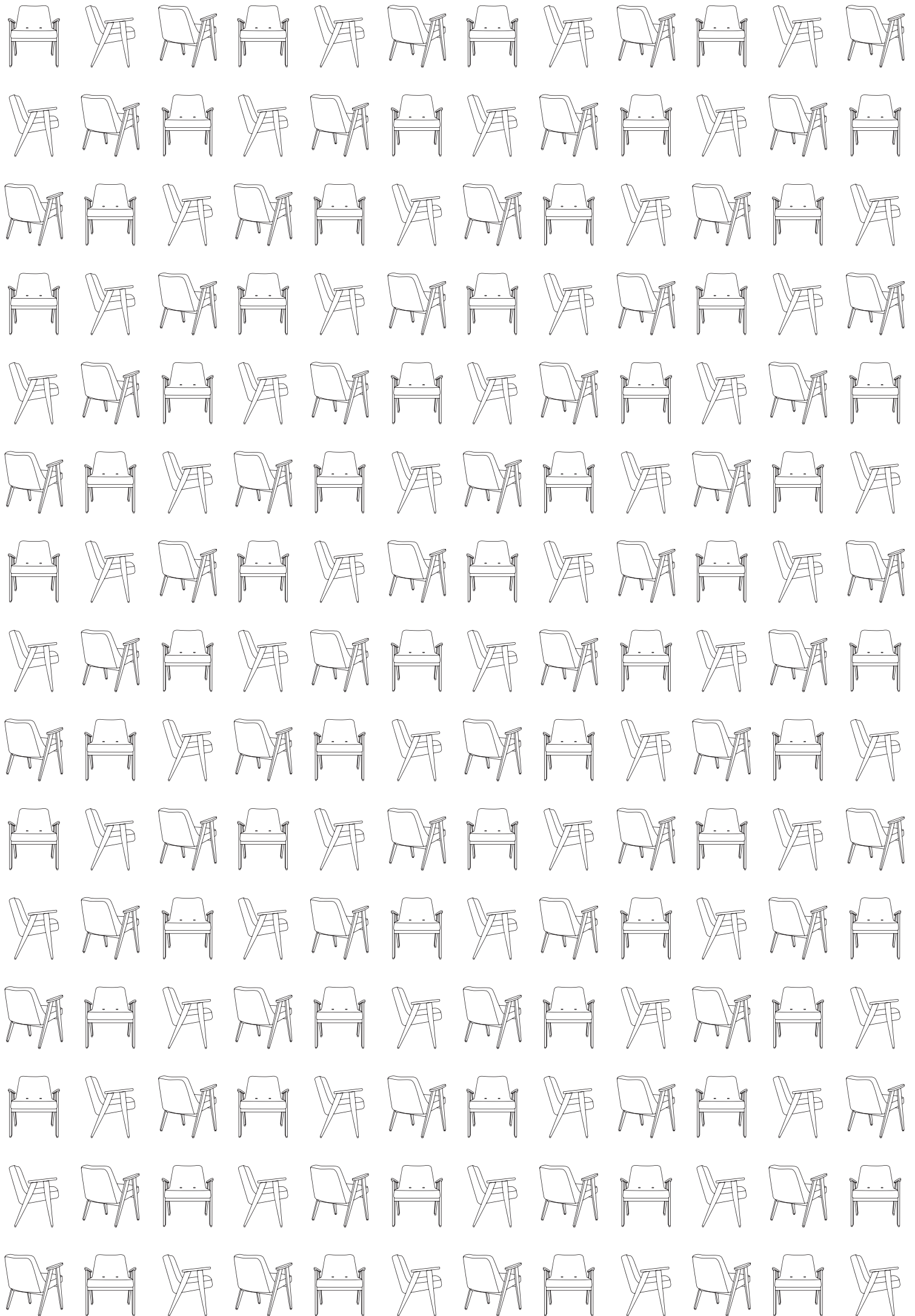



EDITOR & CREATOR
of MID-CENTURY ICONS

