



Heating



Hot water



Renewables

Heat pump brochure

May 2022



Vaillant Comfort for your home



Air source heat pumps aroTHERM plus	4
Air source heat pumps aroTHERM monobloc	7
Air source heat pumps aroTHERM split	11
Hydraulic tower uniTOWER	13
Air source heat pump cylinders aroSTOR	15
Buffer cylinders	17
Ground source heat pumps flexoTHERM	19
Heat pump cylinders uniSTOR	21
Heat pump buffer cylinders allSTOR	23
System controls VRC 700 / VRC 700f	25
System controls sensoCOMFORT	29
Mixing pump groups	33
RDSaP codes	35
aroTHERM plus packs	38



'Be innovative; listen to your customers,' urged our company founder Johann Vaillant back in 1874. This remains our ethos to this day.

Nowadays, that means making optimum use of renewable energy, providing a smart way to control heating via an app, and offering consumers everything they need to make their homes more comfortable - all backed by the quality pledge of a traditional German brand.

We make the same promise for our heat pumps, which allow the end user to exploit the inexhaustible supply of free energy from the earth and air, both now and long into the future. All of our products are developed in Remscheid, Germany and tested under the most extreme climatic conditions in our own laboratories. Manufactured in both Germany and from August 2022 in the our UK Belper plant, Vaillant heat pumps prove their reliability, energy efficiency, and cost-effectiveness on a daily basis. And thus their suitability for what really matters:

Vaillant. Comfort for your home.

aroTHERM plus air source heat pumps



Overview

Released in June 2020, the aroTHERM plus is Vaillant's solution for thinking about tomorrow, today. The ambitious aims of the Paris Climate Agreement can only be achieved when environmental friendliness is combined with outstanding performance.

The aroTHERM plus air-to-water heat pump provides outstanding performance, while reducing its impact on the environment by using R290, a natural refrigerant that has a Global Warming Potential of just three. It also has a higher flow temperature that means an electric immersion heater for Legionella protection isn't necessary.

Available in 3.5, 5, 7, 10, and 12kW outputs.

Key features and benefits

- **Quiet operation**
Sound power as low as 54 dB* for easier planning and more flexible siting options, making it suitable for high density housing, such as terraces.
*based on 3.5/5kW aroTHERM plus
- **Low energy consumption**
With the highest ErP rating of A+++ and an impressive SCOP up to 5.03, the aroTHERM plus delivers excellent energy efficiency
- **Low Global warming potential (GWP)**
aroTHERM plus uses monobloc technology with a hermetically sealed refrigerant circuit using natural refrigerant R290 to deliver an exceptionally low GWP of just 3
- **Quality by design**
Suitable for installations less than 150m away from the sea with salt resistant construction C5 class
- **Ability to cascade up to seven aroTHERM plus heat pumps**
Suitable for larger domestic and commercial properties
- **Compatible with VRC 700, VRC 700f and sensoCOMFORT**



NOTE: VRC 700 / VRC 700f / sensoCOMFORT are not included with the aroTHERM plus packs - see pages 21 - 28 for details. For hybrid packs and prices please contact your Regional Business Manager.

aroTHERM plus with appliance interface			
Description	Article number	ErP rating A+++ to D	Term group
aroTHERM plus 3.5kW and heat pump interface	0010037211	A+++	Renewables
aroTHERM plus 5kW and heat pump interface	0010037212	A+++	Renewables
aroTHERM plus 7kW and heat pump interface	0010037213	A+++	Renewables
aroTHERM plus 10kW and heat pump interface	0010037214	A+++	Renewables
aroTHERM plus 12kW and heat pump interface	0010037215	A+++	Renewables

aroTHERM plus with hydraulic module			
Description	Article number	ErP rating A+++ to D	Term group
aroTHERM plus 3.5kW, hydraulic module and fittings	0010037206	A+++	Renewables
aroTHERM plus 5kW, hydraulic module and fittings	0010037207	A+++	Renewables
aroTHERM plus 7kW, hydraulic module and fittings	0010037208	A+++	Renewables
aroTHERM plus 10kW, hydraulic module and fittings	0010037209	A+++	Renewables
aroTHERM plus 12kW, hydraulic module and fittings	0010037210	A+++	Renewables

aroTHERM plus with uniTOWER			
Description	Article number	ErP rating A+++ to D	Term group
aroTHERM plus 3.5kW, uniTOWER free standing combined tower unit and fittings	0010037201	A+++	Renewables
aroTHERM plus 5kW, uniTOWER free standing combined tower unit and fittings	0010037202	A+++	Renewables
aroTHERM plus 7kW, uniTOWER free standing combined tower unit and fittings	0010037203	A+++	Renewables
aroTHERM plus 10kW, uniTOWER free standing combined tower unit and fittings	0010037204	A+++	Renewables
aroTHERM plus 12kW, uniTOWER free standing combined tower unit and fittings	0010037205	A+++	Renewables

aroTHERM plus hybrid system packs for use with a Vaillant boiler			
Description	Article number	ErP rating A+++ to D	Term group
aroTHERM plus 3.5kW, heat pump interface, decoupler module, VR 10 and VR 32/2	0010037934	A+++	Renewables
aroTHERM plus 5kW, heat pump interface, decoupler module, VR 10 and VR 32/2	0010037935	A+++	Renewables
aroTHERM plus 7kW, heat pump interface, decoupler module, VR 10 and VR 32/2	0010037936	A+++	Renewables
aroTHERM plus 10kW, heat pump interface, decoupler module, VR 10 and VR 32/2	0010037937	A+++	Renewables
aroTHERM plus 12kW, heat pump interface, decoupler module, VR 10 and VR 32/2	0010037938	A+++	Renewables

aroTHERM plus hybrid system packs for use with an incumbent boiler			
Description	Article number	ErP rating A+++ to D	Term group
aroTHERM plus 3.5kW, heat pump interface, decoupler module and VR 10	0010037939	A+++	Renewables
aroTHERM plus 5kW, heat pump interface, decoupler module and VR 10	0010037940	A+++	Renewables
aroTHERM plus 7kW, heat pump interface, decoupler module and VR 10	0010037941	A+++	Renewables
aroTHERM plus 10kW, heat pump interface, decoupler module and VR 10	0010037942	A+++	Renewables
aroTHERM plus 12kW, heat pump interface, decoupler module and VR 10	0010037943	A+++	Renewables

Accessories

Description	Article number	Term group
aroTHERM connection kit for ground install	0010027971	Renewables
aroTHERM connection kit for ground install extension	0010027972	Renewables
aroTHERM connection kit for wall install	0010027974	Renewables
aroTHERM straight pipe connection kit	0010027976	Renewables
750mm flexihose for air-to-water heat pump (pair)	0020165288	Renewables
Snow Spacer	0010027984	Renewables
Wall bracket for insulated wall (Only 3.5kW, 5kW and 7kW)	0020250224	Renewables
Wall bracket for non-insulated wall (Only 3.5kW, 5kW and 7kW)	0020250225	Renewables
Anti-vibration feet large	0020250226	Renewables
Anti-vibration rubber feet (small)	0020252091	Renewables
Coding resistor active cooling	0020269259	Renewables
Discharge vessel	0020145563	Renewables
aroTHERM 45 litre buffer	0010038365	Renewables
aroTHERM heat exchanger module	0020222285	Renewables
aroTHERM inline 6kW back-up heater	0020222286	Renewables
VR 10 temperature sensor	306787	Renewables
VR 32 eBUS coupler	0020139895	Commercial
WH40 low-loss header (flow rates up to 3,000 litres per hour)	306720	Commercial
WH95 low-loss header (flow rates up to 8,000 litres per hour)	306721	Commercial
VR 32/B eBUS coupler (includes housing)	0020235465	Domestic
Ball filter valve 28mm	0010038133	Renewables
Filling pump trolley	0020145706	Renewables
Filling pump	0020166591	Renewables
Protection vessel 18 litres	0020048753	Renewables

aroTHERM monobloc air source heat pumps



Overview

aroTHERM is Vaillant's second generation air-to-water heat pump range, developed with the exacting standards and precision engineering you would expect from Vaillant. It has exceptionally low sound power, so it's ultra-quiet in operation without compromising on energy efficiency or performance.

Our heat pumps can be fitted as part of a hybrid system. Vaillant's proprietary smart controls will intelligently calculate the most efficient appliance in the system to use at any point in time. We are proud to offer one of the most comprehensive



Key features and benefits

- **Four models available**
aroTHERM 5kW, 8kW, 11kW and 15kW (230V)
- **Compatible with VRC 700, VRC 700f and sensoCOMFORT system controls**
Provides optimum system efficiency and a system rating of ErP A+++
- **Ability to cascade up to seven aroTHERM heat pumps**
Suitable for larger domestic and commercial properties
- **Compact size for easy siting**
Possible to fit under a standard window (5kW, 8kW and 11kW)
- **High efficiency ErP A rated pump**
Up to 35% more energy efficient than a standard CH pump
- **Quiet operation**
Sound power as low as 58dB(A) (5kW) with permitted planning available as low as 3 metres
- **Blue fin coated evaporator with anti-hydro coating**
Gives improved performance and extra protection against corrosion in coastal areas



aroTHERM monobloc stand-alone packs

Description	Article number	ErP rating A+++ to D	Term group
aroTHERM 5kW and heat pump interface	0020257346	A++	Renewables
aroTHERM 8kW and heat pump interface	0020257347	A+++	Renewables
aroTHERM 11kW and heat pump interface	0020257348	A+	Renewables
aroTHERM 15kW and heat pump interface	0020257349	A++	Renewables

aroTHERM hybrid system packs for use with a Vaillant boiler

Description	Article number	ErP rating A+++ to D	Term group
aroTHERM 5kW, heat pump interface, heat exchanger module, decoupler module, VR 10 and VR 32/2	0020257350	A++	Renewables
aroTHERM 8kW, heat pump interface, heat exchanger module, decoupler module, VR 10 and VR 32/2	0020257351	A+++	Renewables
aroTHERM 11kW, heat pump interface, heat exchanger module, decoupler module, VR 10 and VR 32/2	0020257352	A+	Renewables
aroTHERM 15kW, heat pump interface, heat exchanger module, decoupler module, VR 10 and VR 32/2	0020257353	A++	Renewables

aroTHERM hybrid system packs for use with an incumbent boiler

Description	Article number	ErP rating A+++ to D	Term group
aroTHERM 5kW, heat pump interface, heat exchanger module, decoupler module and VR 10	0020257354	A++	Renewables
aroTHERM 8kW, heat pump interface, heat exchanger module, decoupler module and VR 10	0020257355	A+++	Renewables
aroTHERM 11kW, heat pump interface, heat exchanger module, decoupler module and VR 10	0020257356	A+	Renewables
aroTHERM 15kW, heat pump interface, heat exchanger module, decoupler module and VR 10	0020257357	A++	Renewables

Accessories		
Description	Article number	Term group
aroTHERM connection kit for ground install	0010027971	Renewables
aroTHERM connection kit for ground install extension	0010027972	Renewables
aroTHERM connection kit for wall install	0010027974	Renewables
aroTHERM straight pipe connection kit	0010027976	Renewables
750mm flexihose for air-to-water heat pump (pair)	0020165288	Renewables
Snow Spacer	0010027984	Renewables
Wall bracket for insulated wall (Only 3.5kW, 5kW and 7kW)	0020250224	Renewables
Wall bracket for non-insulated wall (Only 3.5kW, 5kW and 7kW)	0020250225	Renewables
Anti-vibration feet large	0020250226	Renewables
Anti-vibration rubber feet (small)	0020252091	Renewables
Coding resistor active cooling	0020269259	Renewables
Discharge vessel	0020145563	Renewables
aroTHERM 45 litre buffer	0010038365	Renewables
aroTHERM heat exchanger module	0020222285	Renewables
aroTHERM inline 6kW back-up heater	0020222286	Renewables
VR 10 temperature sensor	306787	Renewables
VR 32 eBUS coupler	0020139895	Commercial
WH40 low-loss header (flow rates up to 3,000 litres per hour)	306720	Commercial
WH95 low-loss header (flow rates up to 8,000 litres per hour)	306721	Commercial
VR 32/B eBUS coupler (includes housing)	0020235465	Domestic
Ball filter valve 28mm	0010038133	Renewables
Filling pump trolley	0020145706	Renewables
Filling pump	0020166591	Renewables
Protection vessel 18 litres	0020048753	Renewables

aroTHERM plus dimensions

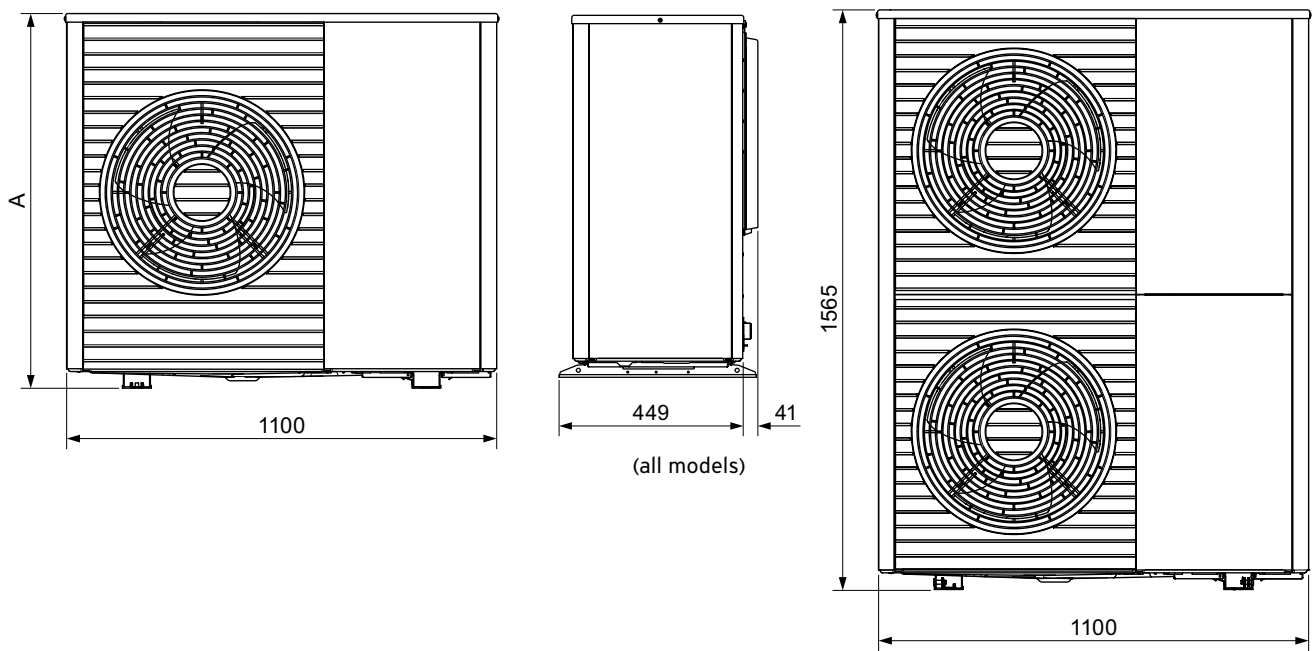

aroTHERM plus 3.5 - 7kW

Description	A
aroTHERM plus 3.5kW	765
aroTHERM plus 5kW	765
aroTHERM plus 7kW	965

aroTHERM plus 10 - 15kW

Description	A
aroTHERM plus 10kW	1565
aroTHERM plus 12kW	1565

aroTHERM monobloc dimensions

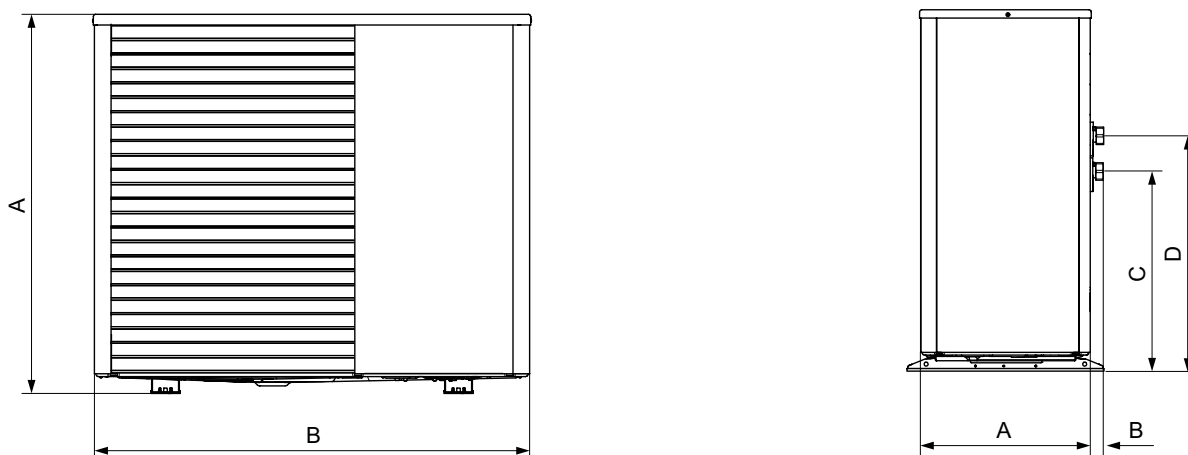

aroTHERM monobloc 5 - 15kW

Description	A	B
aroTHERM 5kW	834	980
aroTHERM 8kW	973	1103
aroTHERM 11kW	973	1103
aroTHERM 15kW	1375	1103

aroTHERM monobloc 5 - 15kW

Description	A	B	C	D
aroTHERM 5kW	408	32	481	581
aroTHERM 8kW	463	32	481	581
aroTHERM 11kW	463	32	481	581
aroTHERM 15kW	463	32	481	581

aroTHERM split air source heat pumps



Overview

Available in 3.5, 5, 7, 10 and 12kW (230V) outputs at A-7/W35, the aroTHERM split is Vaillant's first split refrigerant air-to-water heat pump.

Building on the success of the aroTHERM monobloc models, aroTHERM split has a number of improvements to its design, resulting in better performance, greater efficiency and quieter operating noise.

The aroTHERM split range also features modulating heating and hot water performance, meaning the heat pump adjusts its power to maintain high efficiency, lower noise, to maintain homeowner comfort.



Key features and benefits

- **In-house design, development, testing, and production**
High quality products, performance and support
- **Sound Safe System**
Low sound emissions for easier planning and siting
- **Improved transport and handling**
Aids installation and the siting of the heat pump
- **Same footprint and connections for all outputs**
Easier to plan and execute installations
- **A+++ energy rating with SCoP as high as 4.69***
High efficiency giving lower running costs and saves money with higher RHI payments
*at 35°C
- **Compatible with VRC 700, VRC 700f, and sensoCOMFORT system control with homeowner app**
Quick and easy set-up with installation wizard and fully weather compensating system control
- **Pre-charged for pipe runs up to 15 metres**
Simplifies and reduces installation time



aroTHERM split heat pumps			
Description	Article number	ErP rating A+++ to D	Term group
aroTHERM 3.5kW split**	0010031875	A+++*	Renewables
aroTHERM 5kW split**	0010031876	A+++*	Renewables
aroTHERM 7kW split**	0010031877	A+++*	Renewables
aroTHERM 10kW split**	0010031878	A+++*	Renewables
aroTHERM 12kW split**	0010031879	A+++*	Renewables

*A+++ when used in-conjunction with the VRC 700 / VRC 700f / sensoCOMFORT controller

**Includes indoor and outdoor units

Accessories		
Description	Article number	Term group
Insulated refrigerant pipes, 25m (single coil, 1/4")	0020250311	Renewables
Insulated refrigerant pipes, 25m (single coil, 1/2")	0020250312	Renewables
Insulated refrigerant pipe 25m (single coil 3/8')	0020250309	Renewables
Insulated Refrigerant pipe 25m (single coil 5/8')	0020250310	Renewables
Insulated twin refrigerant pipe 5m - 3.5 and 5kW	0020250307	Renewables
Insulated twin refrigerant pipe 10m - 3.5 and 5kW	0020250308	Renewables
Insulated twin refrigerant pipe 5m - 7, 10 and 12kW	0020250305	Renewables
Insulated twin refrigerant pipe 10m - 7, 10 and 12kW	0020250306	Renewables
SAE Calibration Tool set	0020252903	Renewables
SAE connector set 1/4" for 3.5 and 5kW pack of 10	0020252878	Renewables
SAE connector set 1/2" for 3.5 and 5kW pack of 10	0020252880	Renewables
SAE connector set 3/8" for 7 to 12kW pack of 10	0020252879	Renewables
SAE connector set 5/8" 7 to 12kW Pack of 10	0020252881	Renewables
Wall bracket for insulated wall (Only 3.5kW, 5kW and 7kW)	0020250224	Renewables
Wall bracket for non-insulated wall (Only 3.5kW, 5kW and 7kW)	0020250225	Renewables
Anti-vibration feet (large)	0020250226	Renewables
Snow spacer	0010027984	Renewables
Anti-vibration rubber feet (small)	0020252091	Renewables
Coding resistor active cooling	0020269259	Renewables
aroTHERM 45 litre buffer	0010038365	Renewables
Ball filter valve 28mm	0010038133	Renewables
Filling pump trolley	0020145706	Renewables
Filling pump	0020166591	Renewables
Protection vessel 18 litres	0020048753	Renewables

uniTOWER

Integrated hot water cylinder with hydraulic components



Overview

Released in June 2020, the brand new uniTOWER integrated hot water cylinder with hydraulic components is pre-wired for quick and easy install, acting as the central point of the system diverting the heat to either the heat emitters or hot water outlets. With a 190-litre capacity, the uniTOWER is designed to work in perfect harmony with the aroTHERM plus to deliver high hot water comfort without compromising on efficiency.

The uniTOWER is easy to install, minimising any complicated pipework configuration to ensure minimal disruption to the customer and the aesthetics of the home.

Key features and benefits

- **Robust, compact design**
Provides integrated expansion vessel, cylinder, and diverter valve in a practical design providing quick and easy installation
- **High performance**
190 litre cylinder delivering lower running costs with a system ErP rating of up to A+++, delivering a 25% higher hot water solution with more than 200 litres of hot water per day (at 40°C)
- **Split mounting concept**
Can be installed quickly and easily in one day by two people. Transportation is easier, even in small spaces
- **Hassle free servicing**
Offers straight forward installation and maintenance with all major components accessible from the front



Accessories		
Description	Article number	Term group
uniTOWER HEX plate separation (small) for 3.5 - 7kW models	0010027982	Renewables
uniTOWER HEX plate separation (large) for 10 and 12kW models	0010027973	Renewables
uniTOWER 1" adapter connection kit	0020269275	Renewables
18l Buffer cylinder for uniTOWER	0020269273	Renewables
uniTOWER multizone kit - 1 direct zone	0020170507	Renewables
uniTOWER extension set - 2 direct zones	0020170509	Renewables
uniTOWER extension set - 1 mixed zone	0020170508	Renewables
DHW circulation set without pump	0020170502	Renewables
DHW circulation set with pump	0020170503	Renewables
2L brine expansion vessel	0010030975	Renewables
uniTOWER connect kit (HP circuit)	0010027979	Renewables
uniTOWER connection kit ON wall (UK)	0010027981	Renewables

uniTOWER dimensions and connection dimensions

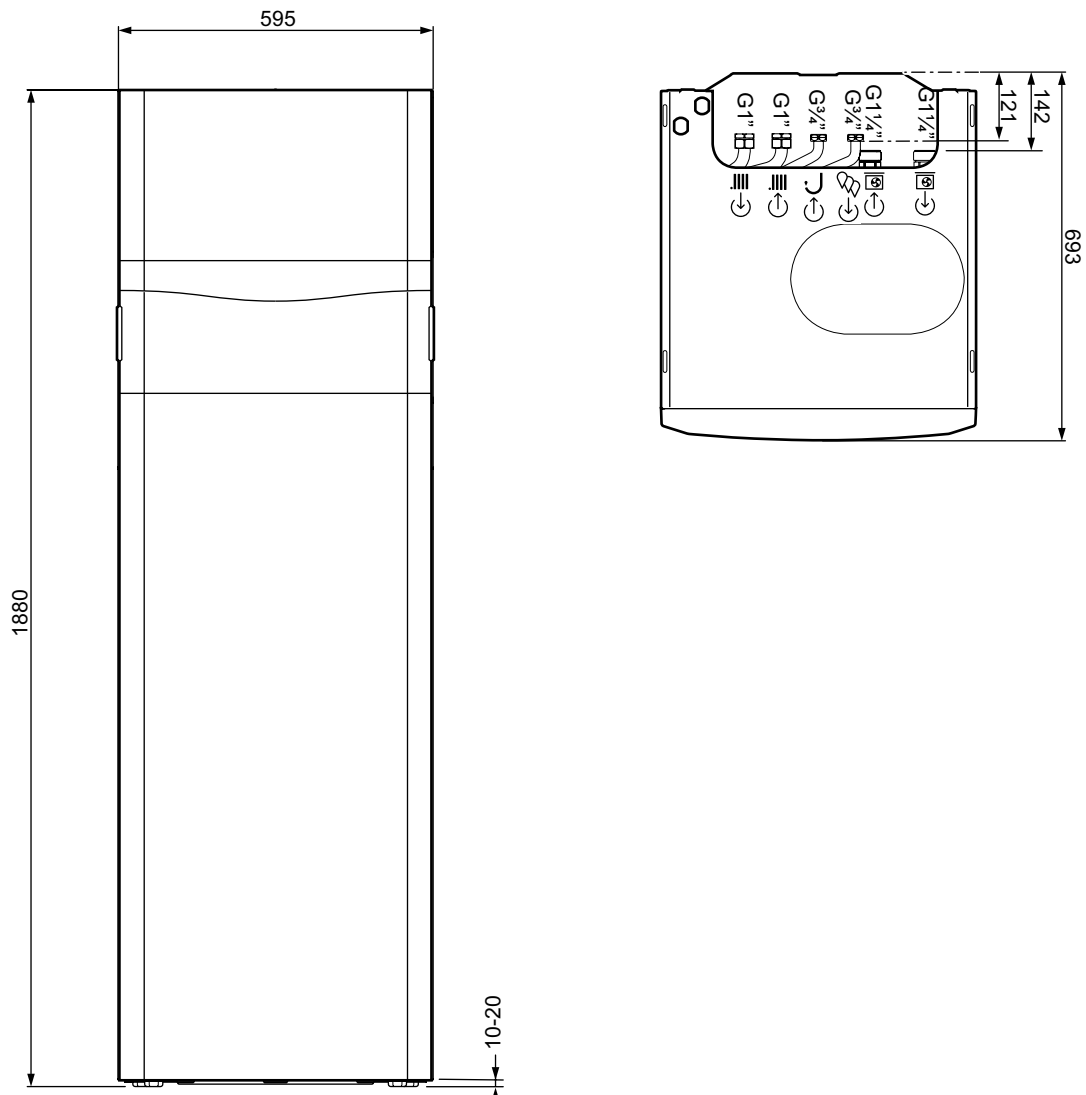

aroSTOR air source heat pump cylinders



Overview

The aroSTOR range of domestic hot water heat pumps features 200 and 270 litre models. It is perfect for additional hot water requirements in larger homes or small businesses where there is a high hot water demand.

This Vaillant heat pump is incredibly efficient and sustainable, using thermal energy to heat hot water. This thermal energy can be collected via an external air duct, or it can recycle hot air from within the room where it's installed, provided there is sufficient ventilation. The only other energy needed is the electricity to run the appliance.

Key features and benefits

- **High quality material and components**
The stainless steel tank comes with a five year warranty (two years for other components)
- **Extremely quiet operation**
Advanced insulation and use of rubber on the compressor for quiet operation
- **Energy efficient and reliable**
Highly efficient heat pump circuit gives COP of $\gt 3.2$ and best possible ErP label of A+
- **Hot water on demand**
Self managing hot water comfort with electrical back up heater for hot water boost (and Legionella protection)
- **In-built control**
For simple and fast installation and use



aroSTOR heat pump cylinders

Description	Article number	ErP rating A+++ to D	Term group
aroSTOR 200 litre	0010031862	A+	Renewables
aroSTOR 270 litre	0010031863	A+	Renewables

Accessories

Description	Article number	Term group
Elbow 90° - D 160mm	0020205773	Renewables
Insulated duct - D160mm L10m	0020205774	Renewables
Twin duct kit aroSTOR VWL 290	0020205775	Renewables

aroSTOR dimensions and connection dimensions

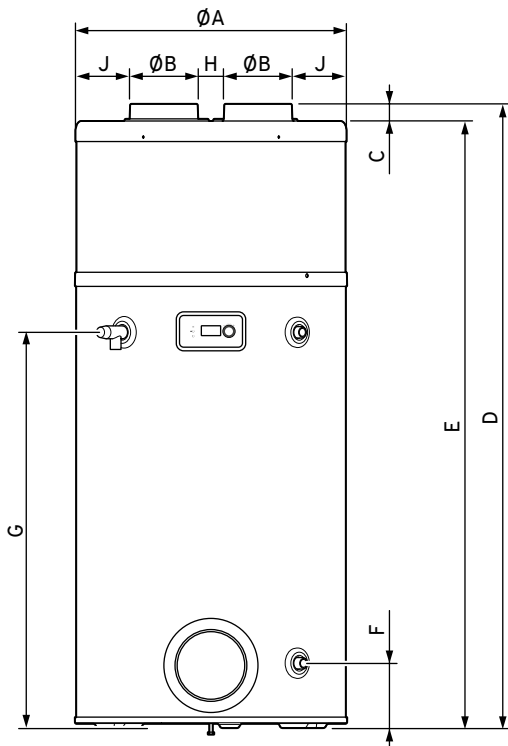

	aroSTOR 200 litre	aroSTOR 270 litre
A	634mm	634mm
B	158mm	158mm
C	40mm	40mm
D	1,458mm	1,783mm
E	1,418mm	1,743mm
F	151mm	151mm
G	924mm	1,249mm
H	134mm	151mm
J	92mm	92mm

Buffer cylinders for heating and cooling



Overview

Vaillant has a range of buffer cylinders for both heating and cooling which can be used on single installs and cascade systems of aroTHERM, flexoTHERM, boilers, or hybrid systems.

The 100 and 200 litre buffer cylinders are smaller and more compact making them the perfect solution for restricted spaces. These buffer cylinders can either perform as a low-loss header ensuring a constant flow of water through the system, as a thermal store for the radiator system, or they can be used for cooling when installed alongside fan coils.

Key features and benefits

- **High levels of insulation**
Minimised heat loss achieving ErP A rating (100 litre) and ErP B rating (200 litre)
- **Inline connections**
Simple and neat installation
- **Insulation ready fitted**
Easier and quicker to install
- **Up to eight connections**
When used with the VR 10 sensor for additional heat sources. Blanking plugs included
- **Ability to cool**
Can be installed onto a system to provide cooling
- **Floor standing and wall-mounted options available (100 litre only)**
Adaptable for restricted locations



Heat pump buffer cylinders

Description	Article number	ErP rating A+ to F	Term group
100 litre buffer cylinder	0020250167	A	Renewables
200 litre buffer cylinder	0020250168	B	Renewables

100 litre buffer vessel dimensions and connection dimensions

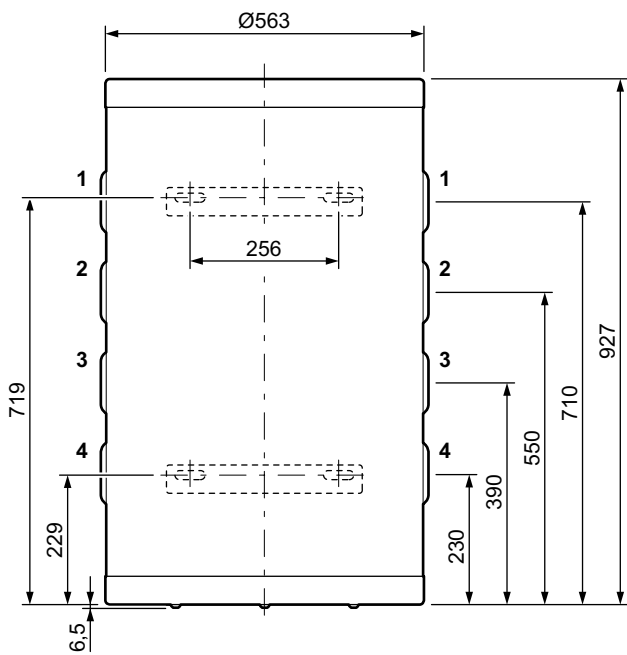

200 litre buffer vessel dimensions and connection dimensions

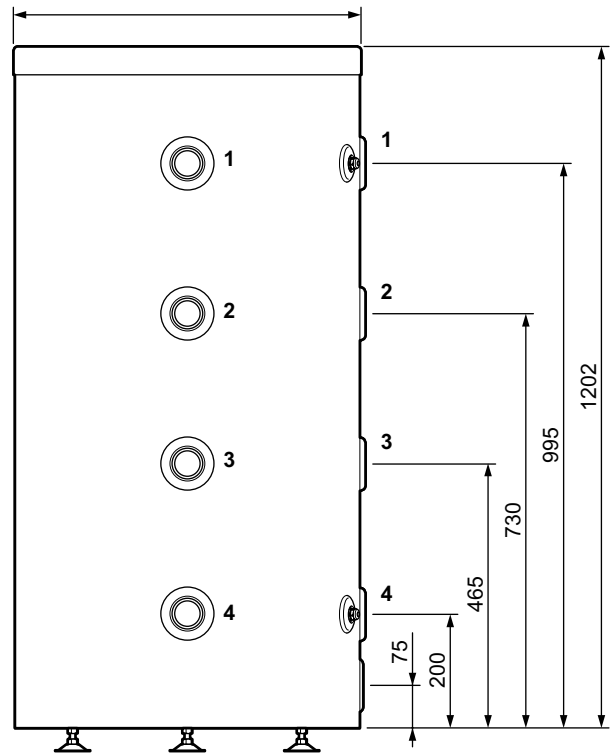

	100 litre	200 litre
1		
2	G1" 1/2 hydraulic connection	G1" 1/2 hydraulic connection
3		
4		

Minimum clearances

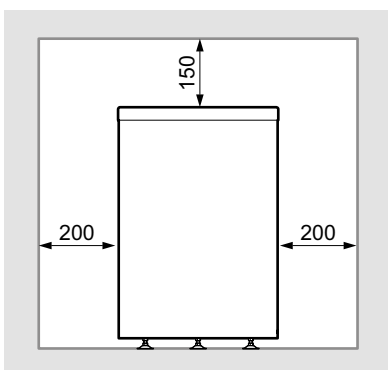

flexoTHERM ground source heat pumps



Overview

flexoTHERM is a ground source heat pump out of the box, but uniquely, the unit can also be converted to accommodate different energy sources such as air or water where required. The flexoTHERM is the most efficient heat pump in the Vaillant portfolio. With its state-of-the-art EVI compressor technology, it delivers high efficiency and heating performance.

The flexoTHERM is the first heat pump to bear Vaillant's Green iQ badge, which indicates a range of products that set a new standard in environmentally friendly heating technologies, with recyclable components and intelligently optimised consumption rates at the core of the range.

It has also been awarded the 'Quiet Mark' seal of approval, issued by the Noise Abatement Society, thanks to its exceptionally low operating noise levels. It sounds no louder than a standard domestic fridge.

Key features and benefits

- **Flexible energy source options**
Can connect to one of the three different heat sources: air (400V only), water, or ground
- **Models are available in two voltages**
230V = 5kW, 8kW and 11kW (ground or water source)
400V = 5kW, 8kW, 11kW, 15kW and 19kW (ground, water, or air source)
- **Compatible with VRC 700, VRC 700f, and sensoCOMFORT system controls**
Ability to cascade up to seven flexoTHERM heat pumps
- **Easy installation**
Built-in ground and heating circulation pumps and three-way diverter valve
- **Extended range of accessories**
A range of accessories for ground, water, or air source applications
- **Exceptionally quiet**
Awarded the 'Quiet Mark' award thanks to noise levels as low as 40dB(A) (400V 5kW)
- **Highest ErP system rating**
A+++ system label when used in conjunction with the VRC 700, VRC 700f, or sensoCOMFORT controls



CERTIFIED



flexoTHERM heat pumps			
Description	Article number	ErP rating A+++ to D	Term group
flexoTHERM 5kW 230V	0020257358	A+++	Renewables
flexoTHERM 8kW 230V	0020257359	A+++	Renewables
flexoTHERM 11kW 230V	0020257360	A+++	Renewables
flexoTHERM 15kW 400V	0020257361	A+++	Renewables
flexoTHERM 19kW 400V	0020257362	A+++	Renewables
flexoTHERM 5kW 400V	0020257363	A+++	Renewables
flexoTHERM 8kW 400V	0020257364	A+++	Renewables
flexoTHERM 11kW 400V	0020257365	A+++	Renewables

Accessories		
Description	Article number	Term group
aroCOLLECT up to 11kW pack (400V)	0020221335	Renewables
aroCOLLECT up to 19kW pack (400V)	0020221336	Renewables
fluoCOLLECT up to 11kW	0010016719	Renewables
fluoCOLLECT up to 19kW	0010016720	Renewables
Passive cooling module up to 11kW	0010016721	Renewables
Passive cooling module up to 19kW	0010016722	Renewables
flexoTHERM straight connection	0020212715	Renewables
flexoTHERM angled connection	0020212716	Renewables
Brine filling station	0020106265	Renewables
Glycol discharge vessel	0020145563	Renewables
18 litre brine expansion vessel (5-11kW)	302097	Renewables
25 litre brine expansion vessel (15-19kW)	302098	Renewables
Expansion vessel bracket	0020173592	Renewables
Heat pump brine de-aerer	0020261123	Renewables
VR 40 multifunctional module 2-in-7	0020017744	Domestic
VR 32 eBUS coupler	0020139895	Commercial
Ball filter valve 28mm (flexoTHERM 5 - 11kW only)	0010038133	Renewables
Protection vessel 18 litres	0020048753	Renewables

uniSTOR heat pump cylinders



Overview

The uniSTOR heat pump cylinder range has been designed to operate specifically with the Vaillant range of heat pumps to provide highly efficient heating and hot water systems. Incorporating a large surface area and smooth coil design within the cylinder, uniSTOR cylinders maximise heat transfer to enable Vaillant heat pumps to run at optimum efficiency, to reduce running costs and increase hot water performance.

Ranging from 150 to 800 litres, our uniSTOR heat pump cylinders are available in both pre-plumbed (150-300 litre only) and standard options, giving you and your customers even more flexibility. In addition to this, the 250 and 300 litre cylinders have an increased coil size making them compatible with a wider range of ground source heat pump systems.

Key features and benefits

- **Duplex stainless steel**
Extremely long life
- **Thermodynamically optimised sensor pocket placement**
Improves system performance
- **Large diameter, smooth bore coil technology**
Provides quiet operation, reduces build-up of scale, and aids in long term efficiency through automatic descaling
- **Thermal injected polyurethane insulation combined with vacuum panels**
Superior insulation and efficiency
- **Global Warming Potential less than five and ozone depletion of zero**
Designed around environmental requirements
- **Adjustable feet**
Makes on-site installation easier



uniSTOR heat pump cylinders			
Description	Article number	ErP rating A+ to F	Term group
uniSTOR 150 litre slimline pre-plumbed cylinder 28mm three-way diverting valve included	0020237129	C	Renewables - Cylinder
uniSTOR 200 litre pre-plumbed cylinder 28mm three-way diverting valve included	0020237130	B	Renewables - Cylinder
uniSTOR 250 litre pre-plumbed cylinder 28mm three-way diverting valve included	0020237131	B	Renewables - Cylinder
uniSTOR 300 litre pre-plumbed cylinder 28mm three-way diverting valve included	0020237132	B	Renewables - Cylinder
uniSTOR 120 litre standard cylinder 28mm three-way diverting valve not included	0020235265	B	Domestic - Cylinder
uniSTOR 150 litre standard cylinder 28mm three-way diverting valve included	0020235271	B	Renewables - Cylinder
uniSTOR 200 litre standard cylinder 28mm three-way diverting valve included	0020235272	B	Renewables - Cylinder
uniSTOR 250 litre standard cylinder 28mm three-way diverting valve included	0020235273	B	Renewables - Cylinder
uniSTOR 300 litre standard cylinder 28mm three-way diverting valve included	0020235274	B	Renewables - Cylinder
uniSTOR 500 litre standard cylinder*	0010019228	C	Commercial - Cylinder
uniSTOR 800 litre standard cylinder (immersion heater not included)*	0010019229	C	Commercial - Cylinder

*One unvented kit and expansion vessel required with each cylinder

auroSTOR solar cylinders			
Description	Article number	ErP rating A+ to F	Term group
auroSTOR 500 litre twin coil cylinder (heat pump/solar)*	0010019234	C	Commercial - Cylinder

*One unvented kit and expansion vessel required with each cylinder

Accessories (500 litre and 800 litre cylinders only)		
Description	Article number	Term group
Immersion heater 7kW (800 litre uniSTOR only)	0020235671	Commercial
Unvented cylinder kit 1"	0020235964	Commercial
Unvented cylinder kit 1¼"	0020235965	Commercial
Unvented cylinder kit 1½"	0020235966	Commercial
Unvented cylinder kit 2"	0020235967	Commercial
Expansion vessel 50 litre (for uniSTOR and auroSTOR 500 litre)	0020229941	Commercial
Expansion vessel 80 litre (for uniSTOR 800 litre)	0020229942	Commercial

allSTOR heat pump buffer cylinders



Overview

The Vaillant range of allSTOR buffer cylinders complements our range of heat pumps. They allow them to operate efficiently, ensure continuous supply even in off periods, and extend the running times of the heat pumps.

The range consists of six cylinders, ranging from 300 to 2,000 litres. They can be cascaded for even greater capacities and flexibility.

Key features and benefits

- **Extended range of buffers up to, 2000 litres**
Compatible with all heat sources and meet the requirements for domestic and commercial systems
- **High levels of insulation**
Minimised heat loss achieving ErP B rating
- **Up to eight connections**
When used with the VR 10 sensor for additional heat sources
- **Inline connections**
Simple and neat installation
- **Clip on insulation**
Easier and lighter to handle in smaller sections and giving greater flexibility during installation
- **Buffers can be installed in cascade**
Greater capacity to cater for larger projects



allSTOR heat pump buffer cylinders			
Description	Article number	ErP rating A+ to F	Term group
allSTOR plus VPS 300 litre	0010015130	B	Renewables
allSTOR plus VPS 500 litre	0010015131	B	Renewables
allSTOR plus VPS 800 litre	0010015132	B	Renewables
allSTOR plus VPS 1,000 litre	0010039301	B	Renewables
allSTOR plus VPS 1,500 litre	0010039302	B	Renewables
allSTOR plus VPS 2,000 litre	0010039302	B	Renewables

allSTOR dimensions and connections

allSTOR heat pump buffer cylinder	
Description	Dimension (A)
allSTOR plus VPS 300 litre	1833mm
allSTOR plus VPS 500 litre	1813mm
allSTOR plus VPS 800 litre	1944mm
allSTOR plus VPS 1,000 litre	2324mm
allSTOR plus VPS 1,500 litre	2362mm
allSTOR plus VPS 2,000 litre	2485mm

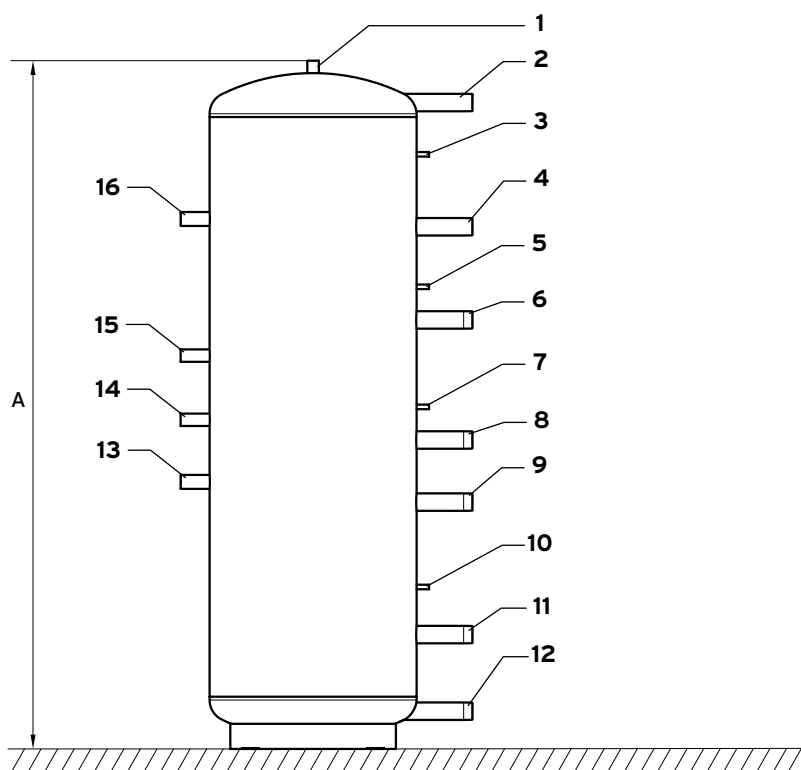

allSTOR connections			
No.	Description	No.	Description
1	Venting sleeve	9	Heating flow line
2	Water connection, flow, drinking water for cascade	10	Sensor pocket
3	Sensor pocket	11	Heating return line
4	Boiler flow	12	Boiler return or return drinking water for cascade
5	Sensor pocket	13	Water connection, return, domestic hot water unit
6	Boiler return	14	Water connection, flow, domestic hot water unit
7	Sensor pocket	15	Water connection, return, solar charging unit
8	Boiler return or heating circuit flow	16	Water connection, flow, solar charging unit

VRC 700 and VRC 700f system controls



Overview

The Vaillant wired VRC 700 and wireless VRC 700f system controls allow your customer to take control of their Vaillant heating and hot water system.

Designed to work harmoniously with all current Vaillant products, the VRC 700 and VRC 700f effortlessly use weather compensation technology to ensure your customers' appliances are working to their peak performance, always maintaining optimum efficiency.

Key features and benefits

- **Designed with simplicity and familiarity in mind**
Uses a familiar menu structure to make controlling the system easy and efficient
- **Intelligently communicates with all Vaillant appliances**
The hybrid management system will automatically choose the most efficient and cost effective appliance to deliver the most cost effective and energy efficient solution
- **Flexible time programs**
Three heating and three hot water time periods can be set for each week, day, or over a 24-hour period
- **Up to three heating circuits with domestic hot water control**
Additional heating zone controls are available in wired (VR 91) and wireless (VR 91f) options and are designed to mirror the functionality of the VRC 700 and VRC 700f
- **Holiday function**
Prevents the heating and hot water coming on whilst away and reinstates it upon return. Ideal for use in schools during the holidays
- **Stored programs are protected from potential power failures**
Holds time and temperature programs permanently, even in the event of a power failure
- **Cascade functionality uses degree minutes in order to calculate when best to use each appliance in turn**
Can control up to seven boilers in cascade and one heat pump or solar thermal appliance. This ensures every appliance is run for an equal amount of time



aroTHERM range and geoTHERM mini system control packs

Pack enables control of the aroTHERM or geoTHERM mini heat pump system, one wired/wireless heating zone, and hot water system.



Pack includes:
One VRC 700(f)

Term group: Domestic

Wired pack:
0020236291

Wireless pack:
0020259829



Pack enables control of the aroTHERM or geoTHERM mini heat pump system, three wired/wireless heating zones, and hot water system.



Pack includes:
VRC 700(f), VR 71 and two VR 91(f)

Term group: Domestic

Wired pack:
0020236294

Wireless pack:
0020259832



Pack enables control of the aroTHERM or geoTHERM mini heat pump system, one wired/wireless heating zone using Vaillant controls, and one heating zone using third party controls, hot water and heat exchanger module.



Pack includes:
VRC 700(f) and VR 70

Term group: Domestic

Wired pack:
0020236292

Wireless pack:
0020259830



Pack enables control of the aroTHERM or geoTHERM mini heat pump system, one wired/wireless heating zone, and solar thermal hot water system.



Pack includes:
VRC 700(f), VR 70 and VR 11

Term group: Domestic

Wired pack:
0020236295

Wireless pack:
0020259833



Pack enables control of the aroTHERM or geoTHERM mini heat pump system, two wired/wireless heating zones, and hot water system.



Pack includes:
VRC 700(f), VR 70 and VR 91(f)

Term group: Domestic

Wired pack:
0020236293

Wireless pack:
0020259831



Pack enables control of the aroTHERM or geoTHERM mini heat pump system, two wired/wireless heating zones, and solar thermal hot water system.



Pack includes:
VRC 700(f), VR 70 VR 11 and VR 91(f)

Term group: Domestic

Wired pack:
0020259834

Wireless pack:
0020259835



flexoTHERM system control packs

Pack enables control of the flexoTHERM heat pump system, one wired/wireless heating zone, and hot water system.



Pack includes:
One VRC 700(f)
Term group: Domestic

Wired pack:
0020236291

Wireless pack:
0020259829



Pack enables control of the flexoTHERM heat pump system, one wired/wireless heating zone, and buffer management.



Pack includes:
VRC 700(f) and VR 70
Term group: Domestic

Wired pack:
0020236292

Wireless pack:
0020259830



Pack enables control of the flexoTHERM heat pump system, two wired/wireless heating zones, and hot water system



Pack includes:
VRC 700(f), VR 70
and VR 91(f)
Term group: Domestic

Wired pack:
0020236293

Wireless pack:
0020259831



Pack enables control of the flexoTHERM heat pump system, one wired/wireless heating zone, and solar thermal hot water system



Pack includes:
VRC 700(f),
VR 70 and VR 11
Term group: Domestic

Wired pack:
0020236295

Wireless pack:
0020259833



Pack enables control of the flexoTHERM heat pump system, three wired/wireless heating zones, and hot water system



Pack includes:
VRC 700(f), VR 71
and two VR 91(f)
Term group: Domestic

Wired pack:
0020236294

Wireless pack:
0020259832



Pack enables control of the flexoTHERM heat pump system, two wired/wireless heating zones, and solar thermal hot water system



Pack includes:
VRC 700(f), VR 70
VR 11 and VR 91(f)
Term group: Domestic

Wired pack:
0020259834

Wireless pack:
0020259835



One heating zone			
Description	Pack contents	Article number	Term group
One wired heating zone and hot water system	VRC 700, VR 70	0020236292	Domestic
One wireless heating zone and hot water system	VRC 700f, VR 70	0020259830	Domestic
One wired heating zone and solar thermal hot water system	VRC 700, VR 70, VR 11	0020236295	Domestic
One wireless heating zone and solar thermal hot water system	VRC 700f, VR 70, VR 11	0020259833	Domestic

Two heating zones			
Description	Pack contents	Article number	Term group
Two wired heating zones and hot water system	VRC 700, VR 70, VR 91	0020236293	Domestic
Two wireless heating zones and hot water system	VRC 700f, VR 70, VR 91f	0020259831	Domestic
Two wired heating zones and solar thermal hot water system	VRC 700, VR 70, VR 11, VR 91	0020259834	Domestic
Two wireless heating zones and solar thermal hot water system	VRC 700f, VR 70, VR 11, VR 91f	0020259835	Domestic

Three heating zones			
Description	Pack contents	Article number	Term group
Three wired heating zones and hot water system	VRC 700, VR 71, two VR 91	0020236294	Domestic
Three wireless heating zones and hot water system	VRC 700f, VR 71, two VR 91f	0020259832	Domestic

VRC 700 / VRC 700f control and components			
Description		Article number	Term group
VRC 700 wired, weather compensating programmable room thermostat		0020236291	Domestic
VRC 700f wireless, weather compensating, programmable room thermostat		0020259829	Domestic
VR 70 wiring centre for up to two zones		0020184844	Domestic
VR 71 wiring centre for up to three zones		0020184847	Domestic
VR 91 wired, additional room thermostat		0020171334	Domestic
VR 91f wireless, additional room thermostat		0020231566	Domestic
VR 40 two-in-seven multifunction module		0020017744	Domestic
VR 11 solar collector NTC		306788	Renewables
VR 10 immersion or contact sensor bare ends		306787	Renewables
VR 32 eBUS coupler		0020139895	Commercial

ambiSENSE			
Description		Article number	Term group
ambiSENSE starter pack (three TRVs)		0020242485	Domestic
VR 50 ambiSENSE radiator valve		0020242487	Domestic
VR 51 ambiSENSE room thermostat		0020247923	Domestic
VR 920 Internet gateway		0020252923	Domestic

sensoCOMFORT system controls

Overview

Vaillant's brand new control, sensoCOMFORT, is available in both wired and wireless options for multi-zone heating systems. sensoCOMFORT has a new modern design which is easy to use and provides the end user full control of their heating and hot water system.

Easy to install, sensoCOMFORT uses eBUS to ensure all the Vaillant products in the system can communicate seamlessly to provide optimum efficiency to the end user.



Key features and benefits

- **Weather compensating**
sensoCOMFORT comes with an outdoor sensor that provides an understanding of the thermal behaviour in and around the property, so it can adjust the flow temperature to ensure the flow temperatures to ensure optimal efficiency
- **Intuitive interface**
The touch interface provides an easy way to navigate the control to undertake simple tasks
- **Energy Dashboard**
Provides a better understanding of energy consumption (kWh) and savings from renewables
- **Compatible with multiple heating circuits with domestic hot water control**
The wired sensoCOMFORT control can control up to five heating circuits and the wireless sensoCOMFORT RF can control up to three
- **Time program assistant**
Effortlessly set-up heating programs within minutes using the time program assistant
- **sensoAPP***
With the sensoNET internet gateway, the sensoAPP can be downloaded and used to manage heating and hot water requirements from a mobile device



*sensoNET (VR 921) internet gateway required

aroTHERM range and geoTHERM mini system control packs

Pack enables control of the aroTHERM or geoTHERM mini heat pump system, one wired/wireless heating zone, and hot water system.



Pack includes:
One sensoCOMFORT (RF)
Term group: Domestic

Wired pack:
0010036819

Wireless pack:
0010036820



Pack enables control of the aroTHERM or geoTHERM mini heat pump system, three wired/wireless heating zones, and hot water system.



Pack includes:
One sensoCOMFORT (RF), VR 71, two VR 92 (f)
Term group: Domestic

Wired pack:
0010036823

Wireless pack:
0010036828



Pack enables control of the aroTHERM or geoTHERM mini heat pump system, one wired/wireless heating zone using Vaillant controls and one heating zone using third party controls, hot water cylinder, and heat exchanger module.



Pack includes:
One sensoCOMFORT (RF), VR 71
Term group: Domestic

Wired pack:
0010036821

Wireless pack:
0010036826



Pack enables control of the aroTHERM or geoTHERM mini heat pump system, four wired heating zones, and hot water system.



Pack includes:
One sensoCOMFORT, VR 71, VR 70, three VR 92
Term group: Domestic

Wired pack:
0010036824



Pack enables control of the aroTHERM or geoTHERM mini heat pump system, two wired/wireless heating zones, and hot water system.



Pack includes:
One sensoCOMFORT (RF), VR 71, VR 92 (f)
Term group: Domestic

Wired pack:
0010036822

Wireless pack:
0010036827



Pack enables control of the aroTHERM or geoTHERM mini heat pump system, five wired heating zones, and hot water system.

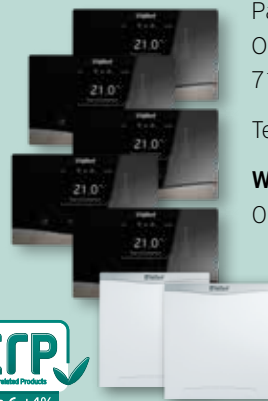

Pack includes:
One sensoCOMFORT, VR 71, VR 70, four VR 92
Term group: Domestic

Wired pack:
0010036825



flexoTHERM control packs

Pack enables control of the flexoTHERM heat pump system, one wired/wireless heating zone, and hot water system or flexoTHERM or geoTHERM mini with third party controls installed post buffer tank.



Pack includes:
One sensoCOMFORT (RF)

Term group: Domestic

Wired pack:
0010036819

Wireless pack:
0010036820



Pack enables control of the flexoTHERM heat pump system, one wired/wireless heating zone, and buffer management.



Pack includes:
One sensoCOMFORT (RF) and VR 71

Term group: Domestic

Wired pack:
0010036821

Wireless pack:
0010036826



Pack enables control of the flexoTHERM heat pump system, two wired/wireless heating zones, and hot water system.



Pack includes:
One sensoCOMFORT (RF), VR 71, VR 92 (f)

Term group: Domestic

Wired pack:
0010036822

Wireless pack:
0010036827



Pack enables control of the flexoTHERM heat pump system, four wired heating zones, and hot water system.



Pack includes:
One sensoCOMFORT, VR 71, VR 70, three VR 92

Term group: Domestic

Wired pack:
0010036824



Pack enables control of the flexoTHERM heat pump system, three wired/wireless heating zones, and hot water system.



Pack includes:
One sensoCOMFORT (RF), VR 71, two VR 92 (f)

Term group: Domestic

Wired pack:
0010036823

Wireless pack:
0010036828



Pack enables control of the flexoTHERM heat pump system, five wired heating zones, and hot water system.



Pack includes:
One sensoCOMFORT, VR 71, VR 70, four VR 92

Term group: Domestic

Wired pack:
0010036825



One heating zone			
Description	Pack contents	Article number	Term group
One wired heating zone and hot water system	sensoCOMFORT and VR 71	0010036821	Domestic
One wireless heating zone and hot water system	sensoCOMFORT RF VR 71	0010036826	Domestic

Two heating zones			
Description	Pack contents	Article number	Term group
Two wired heating zones and hot water system	sensoCOMFORT, VR 71 and VR 92	0010036822	Domestic
Two wireless heating zones and hot water system	sensoCOMFORT RF, VR 71 and VR 92f	0010036827	Domestic

Three heating zones			
Description	Pack contents	Article number	Term group
Three wired heating zones and hot water system	sensoCOMFORT, VR 71 and 2x VR 92	0010036823	Domestic
Three wireless heating zones and hot water system	sensoCOMFORT RF, VR 71 and 2x VR 92f	0010036828	Domestic

Four heating zones			
Description	Pack contents	Article number	Term group
Four wired heating zones and hot water system	sensoCOMFORT, VR 71, VR 70 and 3x VR 92	0010036824	Domestic

Five heating zones			
Description	Pack contents	Article number	Term group
Five wired heating zones and hot water system	sensoCOMFORT, VR 71, VR 70 and 4x VR 92	0010036825	Domestic

sensoCOMFORT / RF controls and accessories			
Description	Article number	Term group	
VR 10 immersion or contact sensor bare ends	306787	Renewables	
VR 32 eBUS coupler	0020139895	Commercial	
sensoCOMFORT wired weather compensating programmable room thermostat	0010036819	Domestic	
sensoCOMFORT RF wireless weather compensating programmable room thermostat	0010036820	Domestic	
VR 70 wiring centre	0020184844	Domestic	
VR 71 wiring centre	0020184847	Domestic	
VR 92 wired additional room thermostat	0020260925	Domestic	
VR 92f wireless additional room thermostat	0020260940	Domestic	
sensoNET internet gateway	0020260963	Domestic	
VR 40 two-in-seven multifunctional module	0020017744	Domestic	
VR 32/B eBUS coupler (includes housing)	0020235465	Domestic	

Mixing pump groups



Overview

The Vaillant mixing pump group is a circulation mixing unit that is intended for heating systems with multiple zones, which operate at different flow temperatures.

The mixing pump group comes equipped with two shut-off valves with in-built thermometers, check valve, and high efficiency circulation pump, all encased within a high quality insulation shell. The mixing pump group also includes a three-way rotary progressive mixing valve and actuator which, combined with our VRC 700 system control, allows fully weather compensated heating across the entire system.

Key features and benefits

- **Outstanding flow control thanks to the progressive character of the valve**
Maintaining comfort needs for the end user
- **Heating curve characteristic**
Provides each zoned area with the perfect heating curve
- **High quality insulation shell**
Aesthetically pleasing whilst minimising noise levels
- **One size fits all**
For a quick and easy installation on all renewables and gas multi-zone systems
- **Plug-in link to Vaillant VR 70 and VR 71 wiring**
Makes installation of the pump quick and easy



Mixing pump group

Description	Article number	Term group
VDM 10 pump group	0020191817	Renewables
VDM 25 1" mixing pump group	0020191788	Renewables
20 ¾" mixing pump group	0020191813	Renewables
15 ½" mixing pump group	0020191814	Renewables
2 zone distribution bar	307556	Renewables
3 zone distribution bar	307597	Renewables

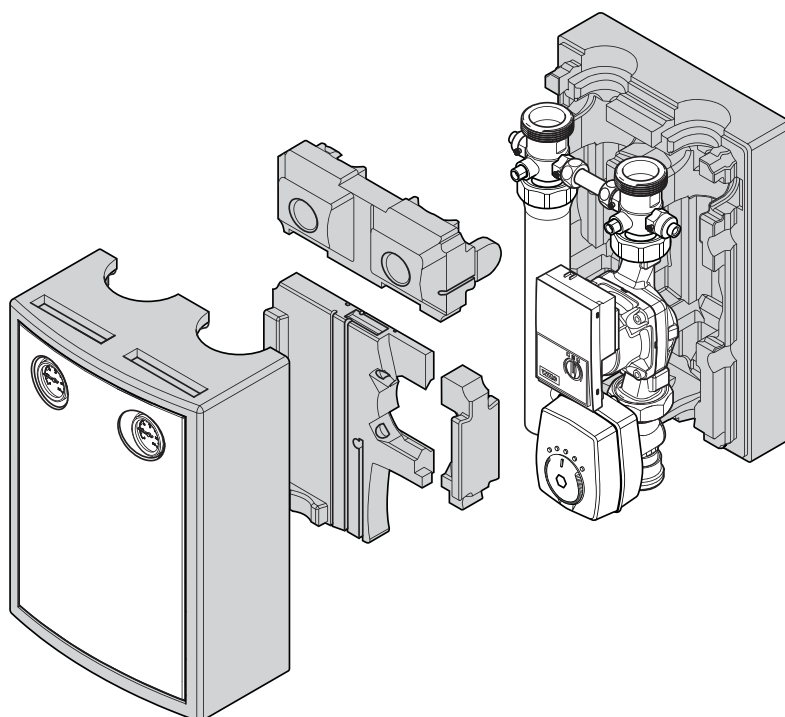

Dimensions/EANs

Description	Unit	Term group
Gross weight	Kg	6.440
Net Weight	Kg	5.410
Volume	M³	0.026
Size / dimensions	mm	400 x 280 x 240
EAN / UPC	BV	4024074734582

RDSaP codes				
Index No.	Range	Marketing name	Model qualifier	Heat emitter
102606	aroTHERM mono	aroTHERM 5kW	VWL 55/3 A 230v	Flow temperature <= 55°C
102607	aroTHERM mono	aroTHERM 5kW	VWL 55/3 A 230v	Flow temperature <= 45°C
102608	aroTHERM mono	aroTHERM 5kW	VWL 55/3 A 230v	Flow temperature <= 35°C
102614	aroTHERM mono	aroTHERM 8kW	VWL 85/3 A 230v	Flow temperature <= 55°C
102615	aroTHERM mono	aroTHERM 8kW	VWL 85/3 A 230v	Flow temperature <= 45°C
102616	aroTHERM mono	aroTHERM 8kW	VWL 85/3 A 230v	Flow temperature <= 35°C
101411	aroTHERM mono	aroTHERM 11kW	VWL 115/2	Flow temperature <= 55°C
101412	aroTHERM mono	aroTHERM 11kW	VWL 115/2	Flow temperature <= 45°C
101413	aroTHERM mono	aroTHERM 11kW	VWL 115/2	Flow temperature <= 35°C
104958	aroTHERM plus	aroTHERM plus 3.5kW with AI	VWL35/6A230V S2 + VWZAIMB	Flow temperature <= 55°C
104959	aroTHERM plus	aroTHERM plus 3.5kW with AI	VWL35/6A230V S2 + VWZAIMB	Flow temperature <= 45°C
104960	aroTHERM plus	aroTHERM plus 3.5kW with AI	VWL35/6A230V S2 + VWZAIMB	Flow temperature <= 35°C
104974	aroTHERM plus	aroTHERM plus 3.5kW with HM	VWL35/6A230VS2 + VWZMEH97/5MB2	Flow temperature <= 55°C
104975	aroTHERM plus	aroTHERM plus 3.5kW with HM	VWL35/6A230VS2 + VWZMEH97/5MB2	Flow temperature <= 45°C
104976	aroTHERM plus	aroTHERM plus 3.5kW with HM	VWL35/6A230VS2 + VWZMEH97/5MB2	Flow temperature <= 35°C
104966	aroTHERM plus	aroTHERM plus 3.5kW with UT	VWL35/6A230VS2+VIHQW190/6EGBMB	Flow temperature <= 55°C
104967	aroTHERM plus	aroTHERM plus 3.5kW with UT	VWL35/6A230VS2+VIHQW190/6EGBMB	Flow temperature <= 45°C
104968	aroTHERM plus	aroTHERM plus 3.5kW with UT	VWL35/6A230VS2+VIHQW190/6EGBMB	Flow temperature <= 35°C
104415	aroTHERM plus	aroTHERM 5kW with AI	VWL55/6A230V S2 + VWZAIMB	Flow temperature <= 55°C
104416	aroTHERM plus	aroTHERM 5kW with AI	VWL55/6A230V S2 + VWZAIMB	Flow temperature <= 45°C
104417	aroTHERM plus	aroTHERM 5kW with AI	VWL55/6A230V S2 + VWZAIMB	Flow temperature <= 35°C
104423	aroTHERM plus	aroTHERM plus 5kW with HM	VWL55/6A230VS2 + VWZMEH97/5MB2	Flow temperature <= 55°C
104424	aroTHERM plus	aroTHERM plus 5kW with HM	VWL55/6A230VS2 + VWZMEH97/5MB2	Flow temperature <= 45°C
104425	aroTHERM plus	aroTHERM plus 5kW with HM	VWL55/6A230VS2 + VWZMEH97/5MB2	Flow temperature <= 35°C
104351	aroTHERM plus	aroTHERM plus 5kW with UT	VWL55/6A230VS2+VIHQW190/6EGBMB	Flow temperature <= 55°C
104352	aroTHERM plus	aroTHERM plus 5kW with UT	VWL55/6A230VS2+VIHQW190/6EGBMB	Flow temperature <= 45°C
104353	aroTHERM plus	aroTHERM plus 5kW with UT	VWL55/6A230VS2+VIHQW190/6EGBMB	Flow temperature <= 35°C
104431	aroTHERM plus	aroTHERM plus 7kW with AI	VWL75/6A230VS2+VWZAMB2	Flow temperature <= 55°C
104432	aroTHERM plus	aroTHERM plus 7kW with AI	VWL75/6A230VS2+VWZAMB2	Flow temperature <= 45°C
104433	aroTHERM plus	aroTHERM plus 7kW with AI	VWL75/6A230VS2+VWZAMB2	Flow temperature <= 35°C
104447	aroTHERM plus	aroTHERM plus 7kW with HM	VWL75/6A230VS2+VWZMEH97/5MB2	Flow temperature <= 55°C
104448	aroTHERM plus	aroTHERM plus 7kW with HM	VWL75/6A230VS2+VWZMEH97/5MB2	Flow temperature <= 45°C
104449	aroTHERM plus	aroTHERM plus 7kW with HM	VWL75/6A230VS2+VWZMEH97/5MB2	Flow temperature <= 35°C
104439	aroTHERM plus	aroTHERM plus 7kW with UT	VWL75/6A230VS2+VIHQW190/6EGBMB	Flow temperature <= 55°C
104440	aroTHERM plus	aroTHERM plus 7kW with UT	VWL75/6A230VS2+VIHQW190/6EGBMB	Flow temperature <= 45°C
104441	aroTHERM plus	aroTHERM plus 7kW with UT	VWL75/6A230VS2+VIHQW190/6EGBMB	Flow temperature <= 35°C
104982	aroTHERM plus	aroTHERM plus 10kW with AI	VWL105/6A230VS2+VWZAIMB2	Flow temperature <= 55°C
104983	aroTHERM plus	aroTHERM plus 10kW with AI	VWL105/6A230VS2+VWZAIMB2	Flow temperature <= 45°C
104984	aroTHERM plus	aroTHERM plus 10kW with AI	VWL105/6A230VS2+VWZAIMB2	Flow temperature <= 35°C
104998	aroTHERM plus	aroTHERM plus 10kW with HM	VWL105/6A230VS2+VWZMEH97/5MB2	Flow temperature <= 55°C
104999	aroTHERM plus	aroTHERM plus 10kW with HM	VWL105/6A230VS2+VWZMEH97/5MB2	Flow temperature <= 45°C
105000	aroTHERM plus	aroTHERM plus 10kW with HM	VWL105/6A230VS2+VWZMEH97/5MB2	Flow temperature <= 35°C
104990	aroTHERM plus	aroTHERM plus 10kW with UT	VWL105/6A230VS2+VIHQW190/6EGBM	Flow temperature <= 55°C

RDSaP codes				
Index No.	Range	Marketing name	Model qualifier	Heat emitter
104991	aroTHERM plus	aroTHERM plus 10kW with UT	VWL105/6A230VS2+VWZMEH97/5MB2	Flow temperature <= 45°C
104992	aroTHERM plus	aroTHERM plus 10kW with UT	VWL105/6A230VS2+VWZMEH97/5MB2	Flow temperature <= 35°C
104455	aroTHERM plus	aroTHERM plus 12kW with AI	VWL125/6A230VS2+VWZAIMB2	Flow temperature <= 55°C
104456	aroTHERM plus	aroTHERM plus 12kW with AI	VWL125/6A230VS2+VWZAIMB2	Flow temperature <= 45°C
104457	aroTHERM plus	aroTHERM plus 12kW with AI	VWL125/6A230VS2+VWZAIMB2	Flow temperature <= 35°C
104471	aroTHERM plus	aroTHERM plus 12kW with HM	VWL125/6A230VS2+VWZMEH97/5MB2	Flow temperature <= 55°C
104472	aroTHERM plus	aroTHERM plus 12kW with HM	VWL125/6A230VS2+VWZMEH97/5MB2	Flow temperature <= 45°C
104473	aroTHERM plus	aroTHERM plus 12kW with HM	VWL125/6A230VS2+VWZMEH97/5MB2	Flow temperature <= 35°C
104463	aroTHERM plus	aroTHERM plus 12kW with UT	VWL125/6A230VS2+VIHQW190/6EGBM	Flow temperature <= 55°C
104464	aroTHERM plus	aroTHERM plus 12kW with UT	VWL125/6A230VS2+VWZMEH97/5MB2	Flow temperature <= 45°C
104465	aroTHERM plus	aroTHERM plus 12kW with UT	VWL125/6A230VS2+VWZMEH97/5MB2	Flow temperature <= 35°C

AI = Appliance interface HM = Hydraulic module UT = uniTOWER

103722	aroTHERM split	aroTHERM 3.5kW	VWL 35/5 AS 230V S2+ VWL57/5IS	Flow temperature <= 55°C
103723	aroTHERM split	aroTHERM 3.5kW	VWL 35/5 AS 230V S2+ VWL57/5IS	Flow temperature <= 45°C
103724	aroTHERM split	aroTHERM 3.5kW	VWL 35/5 AS 230V S2+ VWL57/5IS	Flow temperature <= 35°C
103746	aroTHERM split	aroTHERM 5kW	VWL 55/5 AS230v S2 +VWL 57/5IS	Flow temperature <= 55°C
103747	aroTHERM split	aroTHERM 5kW	VWL 55/5 AS230v S2 +VWL 57/5IS	Flow temperature <= 45°C
103748	aroTHERM split	aroTHERM 5kW	VWL 55/5 AS230v S2 +VWL 57/5IS	Flow temperature <= 35°C
103778	aroTHERM split	aroTHERM 7kW	VWL 75/5 AS 230vS2+VWL 77/5 IS	Flow temperature <= 55°C
103779	aroTHERM split	aroTHERM 7kW	VWL 75/5 AS 230vS2+VWL 77/5 IS	Flow temperature <= 45°C
103780	aroTHERM split	aroTHERM 7kW	VWL 75/5 AS 230vS2+VWL 77/5 IS	Flow temperature <= 35°C
103786	aroTHERM split	aroTHERM 10kW	VWL 105/5 AS S2 + VWL127/5 IS	Flow temperature <= 55°C
103787	aroTHERM split	aroTHERM 10kW	VWL 105/5 AS S2 + VWL127/5 IS	Flow temperature <= 45°C
103788	aroTHERM split	aroTHERM 10kW	VWL 105/5 AS S2 + VWL127/5 IS	Flow temperature <= 35°C
103754	aroTHERM split	aroTHERM 12kW	VWL 125/5 AS S2 + VWL 127/5IS	Flow temperature <= 55°C
103755	aroTHERM split	aroTHERM 12kW	VWL 125/5 AS S2 + VWL 127/5IS	Flow temperature <= 45°C
103756	aroTHERM split	aroTHERM 12kW	VWL 125/5 AS S2 + VWL 127/5IS	Flow temperature <= 35°C
104014	aroSTOR	aroSTOR 200ltr	VWL B 200/5 UK	Variable
104015	aroSTOR	aroSTOR 270ltr	VWL B 270/5 UK	Variable
102974	flexoTHERM	flexoTHERM 5kW	VWF 57/4 230V	Flow temperature <= 55°C
102975	flexoTHERM	flexoTHERM 5kW	VWF 57/4 230V	Flow temperature <= 45°C
102976	flexoTHERM	flexoTHERM 5kW	VWF 57/4 230V	Flow temperature <= 35°C
102982	flexoTHERM	flexoTHERM 8kW	VWF 87/4 230V	Flow temperature <= 55°C
102983	flexoTHERM	flexoTHERM 8kW	VWF 87/4 230V	Flow temperature <= 45°C
102984	flexoTHERM	flexoTHERM 8kW	VWF 87/4 230V	Flow temperature <= 35°C
102990	flexoTHERM	flexoTHERM 11kW	VWF 117/4 230V	Flow temperature <= 55°C
102991	flexoTHERM	flexoTHERM 11kW	VWF 117/4 230V	Flow temperature <= 45°C
102992	flexoTHERM	flexoTHERM 11kW	VWF 117/4 230V	Flow temperature <= 35°C
102998	flexoTHERM	flexoTHERM 15kW	VWF 157/4	Flow temperature <= 55°C
102999	flexoTHERM	flexoTHERM 15kW	VWF 157/4	Flow temperature <= 45°C
103000	flexoTHERM	flexoTHERM 15kW	VWF 157/4	Flow temperature <= 35°C
103006	flexoTHERM	flexoTHERM 19kW	VWF 197/4	Flow temperature <= 55°C

RDSaP codes				
Index No.	Range	Marketing name	Model qualifier	Heat emitter
103007	flexoTHERM	flexoTHERM 19kW	VWF 197/4	Flow temperature ≤ 45°C
103008	flexoTHERM	flexoTHERM 19kW	VWF 197/4	Flow temperature ≤ 35°C

RDSaP codes			
Index No.	Model name	Model qualifier	Heat emitter
200036	VRC 700	ErP Class VI	3
200074	sensioHOME VRT 380	ErP Class VI	3

aroTHERM plus packs - the following items are only sold as part of the aroTHERM sales pack



Heat pump control interface module

- Simplest adaptation on all kind of applications e.g.:
 - coverage of higher DHW demand
 - integration of existing DHW cylinders
 - Hybrid systems
- Freedom to place Heating system components to suit property lay out.
- Used as part of a hybrid system linking and boiler and heat pump together
- 230V Connection
- Installation wizard



Hydraulic module

- Flexible adaptation on all kind of applications e.g.:
 - coverage of higher DHW demand
 - integration of solar thermal
 - integration of existing DHW cylinders
- Includes system expansion, diverter valve back up heater, HP interface
- Heating expansion vessel size 10 litre inside
- High modulating back up heater up to 6kW
- Integrated 3-way valve
- Connection of 230V and 400V possible



uniTOWER hydraulic tower

- Easy expansion and component integration
- Compact installation with integrated DHW solution
- More than 200 litres hot water a day (40°C)
- Increase of hot water tapping up to +25% possible**
- DHW COP 2,6 (Load profile XL)
- Simple transport and installation with Split Mounting Concept
- Heating expansion vessel size 15 L inside (one of the biggest in the market) for houses up to 160 m²

Customer service support contact details

Whether you're planning or fitting a new heating system, need technical assistance, or simply more information, Vaillant will be able to help.

Sales support

Vaillant products are available to purchase from reputable heating merchants in the UK. To find contact details for your nearest Vaillant sales representative
Telephone: 0345 602 0262

Technical enquiries

For technical assistance:
Telephone: 0330 100 3540

General enquiries

If you have a general enquiry our friendly reception staff will happily point you in the right direction:
Telephone: 0345 602 2922

Renewable service

For renewable products aftersales, service, and commissioning
Telephone: 0330 100 3540
Email: aftersales@vaillant.co.uk

Training enquiries

Vaillant provide many different training courses. For more information:
Telephone: 0345 601 8885
Email: training@vaillant.co.uk

System Sales & Design

For technical assistance:
Email: systemdesignuk@vaillant.com