

# SPECIFICATIONS

## MEASUREMENTS

|                               |                            |
|-------------------------------|----------------------------|
| Lamps                         | Metal halide 4 x 1,050 W   |
| Lumens                        | 108,000                    |
| Available power output        | 1.8 kw                     |
| Generator                     | Brushless 60 Hz, 6.0 kW    |
| Engine                        | D-1105Kubota Diesel-       |
| Receptacles                   | One GFI duplex 20 A/ 120 V |
| Fuel capacity                 | 45 gal (170 L)             |
| Wheelsize                     | 13 in (33 cm)              |
| Axle rating                   | 2,200lbs (997 kg)          |
| Tongue weight travel position | 210 lbs (90 kg)            |
| Total weight no fuel          | 1,600 lbs (659 kg)         |

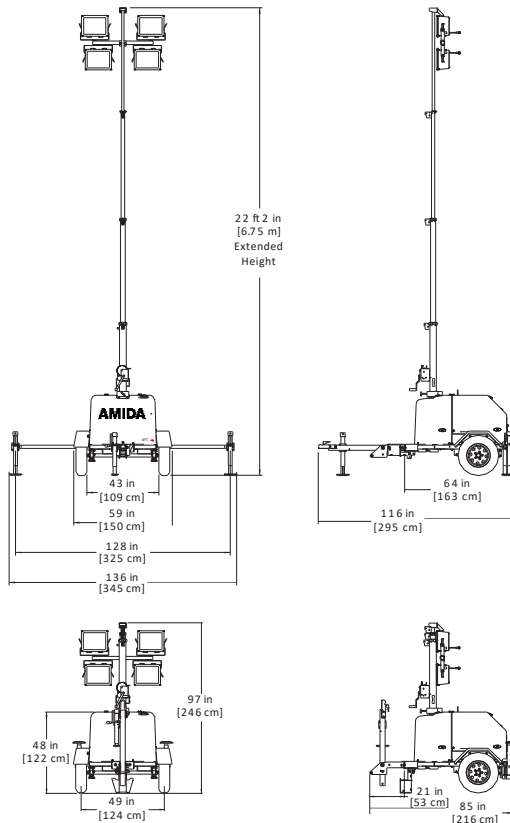

Notice: Metal halide lamp bulbs contain mercury (Hg). Dispose of lamp bulbs according to local, state and federal laws.

## FEATURES

Durable 23.4 ft / 7.13 m vertical mast with manual self braking winch, mast brake and 359 degree mast rotation for quick setup and light positioning

4x1050w square cast aluminum metal halide lamps, Kubota 17.7hp engine, 45 gal / 170L fuel tank and 6kW generator provide up to 20 hours of run time

Efficient design layout allows up to 17 units per truckload, with fork pockets and lifting eye for quick loading and unloading

Heavy-Duty steel covers provides ample access for service and maintenance, with locking tabs for security

Platform to access lights and fold up tongue for transport

Standard engine protection includes high water temperature and low oil auto shutdown

DOT approved run, stop and turn lights, standard

## APT4 MH LIGHT TOWER



## CHASSIS OPTIONS

AMIDA® branding and white paint. Standard

Multiple hitch configurations

Customer specific decals and Color options available

## ENGINE OPTIONS

6kW, 60 Hz generator with 17.7 hp Kubota® diesel

## TOWER OPTIONS

Optional Electric Winch

## COLD WEATHER OPTIONS

800 CCA battery

Low temperature coolant mix











Engine block heater

# AMIDA

# Built to Last

# APT4 MH Light Tower

## Specifications

| Models   | APT4      |         |
|--|-----------|---------|
| Measurements   | US        | Metric  |
|  Mast height            | 22.2 ft   | 6.75 m  |
|  Inside track width     | 43 in     | 109 cm  |
|  Width - stowed         | 59 in     | 150 cm  |
|  Width - deployed       | 128 in    | 325 cm  |
|  Width - operating      | 136 in    | 345 cm  |
|  Length - to step       | 64 in     | 163 cm  |
|  Length - overall       | 116 in    | 295 cm  |
|  Height - cabinet       | 48 in     | 122 cm  |
| Height - stowed  | 97 in     | 246 cm  |
|  Track width            | 49 in     | 124 cm  |
|  Tongue length - stowed | 21 in     | 53 cm   |
|  Length - stowed        | 85 in     | 216 cm  |
| Fuel capacity  | 45 gal    | 170 L   |
| Wheel size   | 13 in     | 33 cm   |
| Axle rating  | 2,200 lbs | 998 kg  |
| Machine weight no fuel   | 1,600 lbs | 726 kg  |
| Tongue weight travel position  | 210 lbs   | 95.3 kg |

## Dimensions

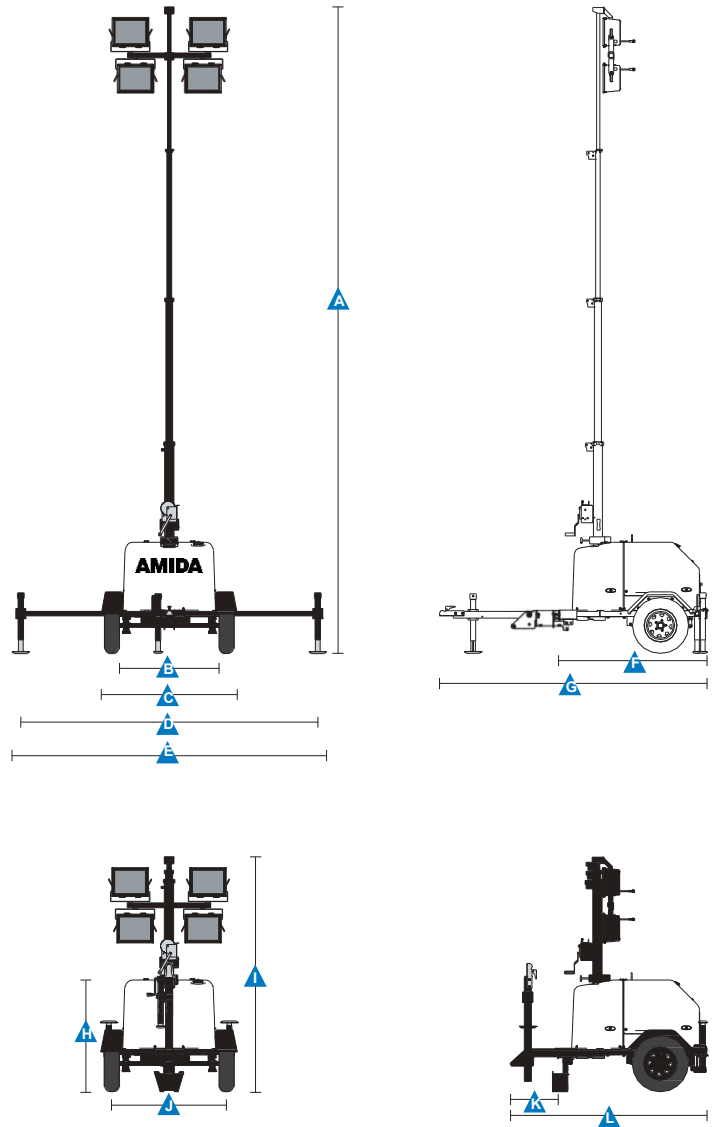

Notice: Metal halide lamp bulbs contain mercury (Hg). Dispose of lamp bulbs according to local, state and federal laws.

## Features

### Standard Features

#### Measurements

- Metal halide 4 x 1,050 W Lamps
- Brushless 60 Hz, 6.0 kW Generator
- Kubota D-1105 Diesel Engine
- One GFI duplex 20 A / 120 V Receptacles
- 45 gal (170 L) Fuel capacity
- 13 in (33 cm) Wheel size
- 2,200 lbs (998 kg) Axle rating
- 203 lbs (92 kg) Tongue weight travel position
- 1,600 lbs (726 kg) Total weight no fuel

#### Productivity

- Durable 23.4 ft / 7.13 m vertical mast with manual self braking winch, mast brake and 359 degree mast rotation for quick setup and light positioning
- 4x1050w square cast aluminum metal halide lamps, Kubota Diesel Engine, 45 gal / 170 L fuel tank and 6kW generator provide up to 90 hours of run time
- Efficient design layout allows up to 17 units per truckload, with fork pockets and lifting eye for quick loading and unloading
- Heavy-Duty steel covers provides ample access for service and maintenance, with locking tabs for security
- Platform to access lights and fold up tongue for transport
- Standard engine protection includes high water temperature and low oil auto shutdown
- DOT approved run, stop and turn lights, standard

### Options & Accessories

#### Chassis Options

- AMIDA branding and white paint
- Customer specific decals and Color options available
- Multiple hitch configuration

#### Engine Options

- 6 kW, 60 Hz generator with Kubota® diesel
- One T/L 30A/240V receptacle

#### Tower Options

- Electric Winch

#### Cold Weather Options

- 800 CCA battery
- Low temperature coolant mix
- Engine block heater



### Amida

132 Grayson Road  
Rock Hill, South Carolina 29732  
Telephone +1 (803) 328-1134  
Fax +1 (901) 948-3006

### Distributed By: