

# SPECIFICATIONS

## APT4 LED3

### MEASUREMENTS

Lamps	LED4 x 320W
Lumens	47,000lm
Available power output	1.82 kw
Generator	Brushless 60 Hz 3.1kW
Engine	Kubota Diesel Engine
Receptacles	One GFI duplex 20 A/ 120 V
Fuel capacity	45 gal (170 L)
Wheelsize	13 in (33 cm)
Axle rating	2,200lbs (997 kg)
Tongue weight travel position	210 lbs (90 kg)
Total weight no fuel	1,600 lbs (659 kg)

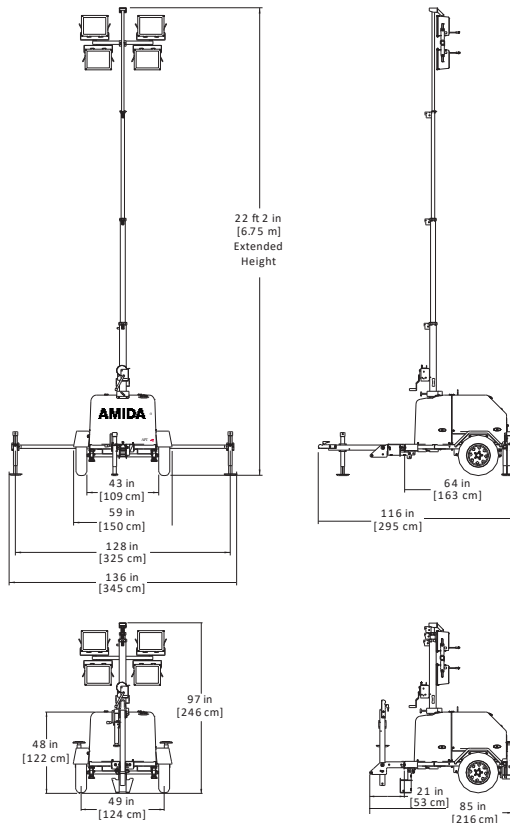

### CHASSIS OPTIONS

AMIDA® branding and white paint Standard Multiple hitch configurations

Customer specific decals and Color options available

### ENGINE OPTIONS

3.1kW 60 Hz generator with Kubota Diesel Engine

### FEATURES

Durable 23.4 ft / 7.13 m vertical mast with manual self braking winch, mast brake and 359 degree mast rotation for quick setup and light positioning

4x320w LED Lamps, Kubota Diesel engine, 45 gal / 170 L fuel tank and 3.1kW generator provides 3 times run time of MH light tower

Efficient design layout allows up to 17 units per truckload, with fork pockets and lifting eye for quick loading and unloading

Heavy-Duty steel covers provides ample access for service and maintenance, with locking tabs for security

Platform to access lights and fold up tongue for transport

Standard engine protection includes high water temperature and low oil auto shutdown

DOT approved run, stop and turn lights, standard

### TOWER OPTIONS

Optional Electric Winch

### COLD WEATHER OPTIONS

800 CCA battery

Low temperature coolant mix

Engine block heater



# Built to Last

### Specifications

Models	APT4	
Measurements	US	Metric
<b>A</b> Mast height	22.2 ft	6.75 m
<b>B</b> Inside track width	43 in	109 cm
<b>C</b> Width - stowed	59 in	150 cm
<b>D</b> Width - deployed	128 in	325 cm
<b>E</b> Width - operating	136 in	345 cm
<b>F</b> Length - to step	64 in	163 cm
<b>G</b> Length - overall	116 in	295 cm
<b>H</b> Height - cabinet	48 in	122 cm
Height - stowed	97 in	246 cm
<b>A</b> Track width	49 in	124 cm
<b>K</b> Tongue length - stowed	21 in	53 cm
<b>L</b> Length - stowed	85 in	216 cm
Fuel capacity	45 gal	170 L
Wheel size	13 in	33 cm
Axle rating	2,200 lbs	998 kg
Machine weight no fuel	1,600 lbs	726 kg
Tongue weight travel position	210 lbs	95.3 kg

### Dimensions

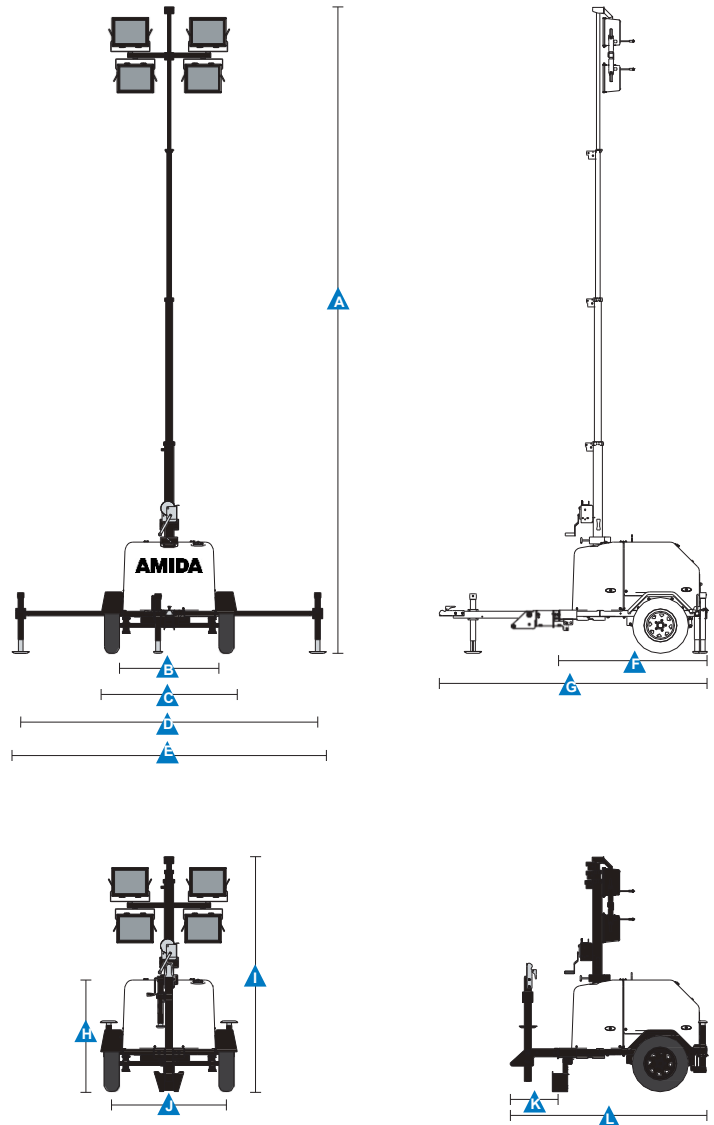

## Features

### Standard Features

#### Measurements

- LED panels 4 x 320W
- Brushless 60 Hz, 3.1 kW Generator
- Kubota Diesel Engine
- One GFI duplex 20 A / 120 V Receptacles
- 45 gal (170 L) Fuel capacity
- 13 in (33 cm) Wheel size
- 2,200 lbs (998 kg) Axle rating
- 203 lbs (92 kg) Tongue weight travel position
- 1,600 lbs (726 kg) Total weight no fuel

#### Productivity

- Durable 23.4 ft / 7.13 m vertical mast with manual self braking winch, mast brake and 359 degree mast rotation for quick setup and light positioning
- 4x320W square LED lamps, Kubota Diesel Engine, 45 gal / 170 L fuel tank and 3.1kW generator provide up to 3 times hours of run time over MH bulbs
- Efficient design layout allows up to 17 units per truckload, with fork pockets and lifting eye for quick loading and unloading
- Heavy-Duty steel covers provides ample access for service and maintenance, with locking tabs for security
- Platform to access lights and fold up tongue for transport
- Standard engine protection includes high water temperature and low oil auto shutdown
- DOT approved run, stop and turn lights, standard

### Options & Accessories

#### Chassis Options

- AMIDA branding and white paint
- Customer specific decals and Co options available
- Multiple hitch configuration

#### Engine Options

- 3.1 kW, 60 Hz generator with Kubota® diesel
- One GFI duplex 20 A / 120 V Receptacles

#### Tower Options

- Electric Winch

#### Cold Weather Options

- 800 CCA battery
- Low temperature coolant mix
- Engine block heater



### Amida

132 Grayson Road  
Rock Hill, South Carolina 29732  
Telephone +1 (803) 328-1134  
Fax +1 (901) 948-3006

### Distributed By: