



800 SERIES OVEN RANGES

505 mm Fan Forced Oven

PE2S12G20FF - Electric

- High performance easy to clean 2 kW solid hot plates
- Stainless steel fascia and sides, spill zone and drip trays for ease of cleaning
- Flexible, modular cooktop design enables many combinations of elements and griddle
- Fan forced oven in gastronorm compatible sizes
- Ovens are fully insulated vitreous enamel for even heat and easy cleaning
- Heavy duty welded steel body for rigidity and durability

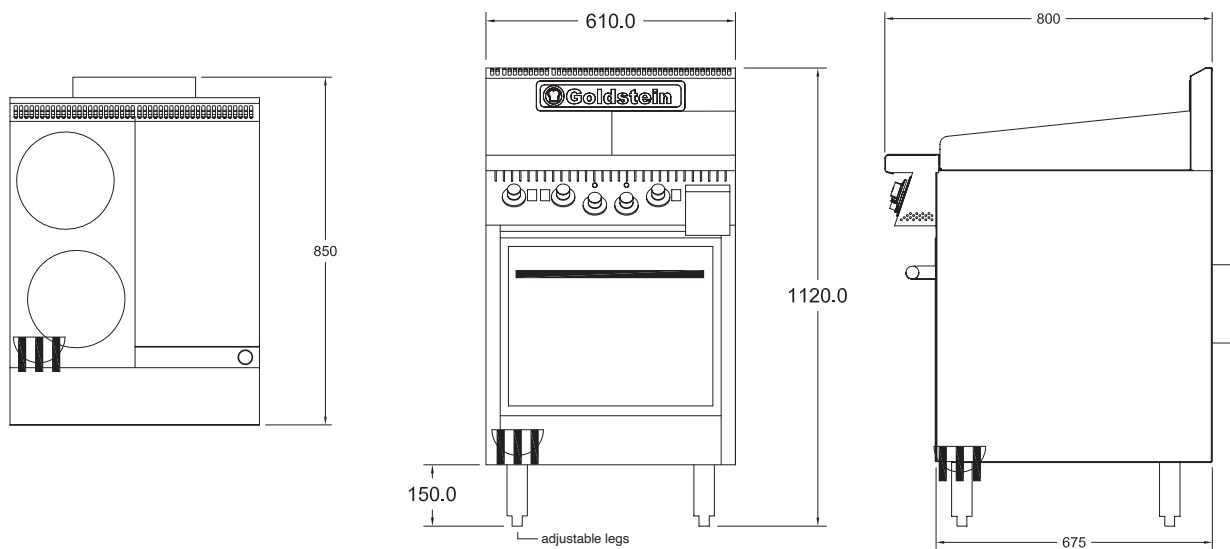

PE2S12G20FF

SPECIFICATIONS

Dimensions (WxDxH)	610 x 850* x 1120 mm
Working height	914 mm
Solid Plates	2
Griddle size (WxH)	305 x 12 mm

Weight	129 kg
Packed	0.5 m ³
Electric Connection	3 phase, 415V + N + E
Rating	16 kW

*extra depth for fan motor only

Australia's premier food service equipment manufacturer

middleby.com.au

211-217 Woodpark Road, Smithfield NSW 2164
1800 013 123 | +61 2 9604 7333

 **MIDDLEBY AUSTRALIA**

