

# TC Combi-Eco

- An integrated solution that automates screen developing & highpressure washing for screen cleaning.



*simplicity in performance*



## Dual Function

The versatile design enables the TC Combi-Eco to function as both a screen developing unit and highpressure rinsing/washing system for cleaning screens.



## Quick ROI

The automation of the TC Combi-Eco reduces labor in all water rinsing areas for pre- & post press. Labor savings combined with the economical equipment price makes for a rapid return on your investment.



## Fully Automated

The solution for automated screen developing. Connect an optional in-line UV-LED exposure unit for the perfect compliment to a Computer to Screen based imaging system.

**KOR-CHEM**

## SCREEN AUTOMATION IN PRE- AND POSTPRESS

When you are looking to reduce your labor time and work more efficiently, the Combi-Eco is the perfect fit!

The fully automatic TC Combi-Eco system offers screen developing as well as highpressure rinsing/washing for cleaning screens. Next to the stand-alone version the TC Combi-Eco can also be connected with the optional in-line UV LED exposure system.

The automatic highpressure rinse provides the perfect solution for rinsing screens with the special INPRO nozzle system to achieve the highest cleaning results. When washing out a printed screen, first remove the ink from the screen in a diptank or a manual ink removal booth. Then, simply place the screen on the belt and the screen will be fully cleaned and dried automatically. The TC Combi-Eco is also suitable for highpressure cleaning the de-ghoster, decoater, water ink and degreaser.

For developing the screen, just turn 2 valves and the screen will be fully automatically developed. Pressure rinse jets produce fast and dependable washout results. In this way you create a multiple use of the TC Combi-Eco and have a very fast return on your investment.

The automatic screen Exposure & Developing system provides the perfect solution for fully automatic screen production to compliment Computer to Screen based screen imaging systems. The Combi-Eco offers excellent expose & washout for all types of artwork including very fine linework and subtle highlight halftone dots.

The UV-LED box offers ultra fast screen exposure, powerful and reliable UV-LEDs are laid out on a full panel array to provide a focused, and even spread of UV light across the screen. The LEDs have been selected to provide the ideal wavelength to work with all types of screen emulsion. With the optional docking kit, existing or new to install UV-LED boxes can be connected with the Combi-Eco.

## Tigerclean Combi-Eco Features

- fully automatic highpressure wash for cleaning the screens
- fully automatic screen exposure & developing
- no dedicated people needed for developing finer mesh
- labor saving for all water rinse needed in pre- & postpress
- highest results due to also the special Nozzle system
- safer working conditions
- simple design and easy to use and maintain
- heavy duty machine build with A1 parts
- budget priced machine with a fast ROI of 1 - 1.5 years
- customer can install this plug&play Combi-Eco machine
- Inpro technology "simplicity in performance"
- highest safety and marked CE

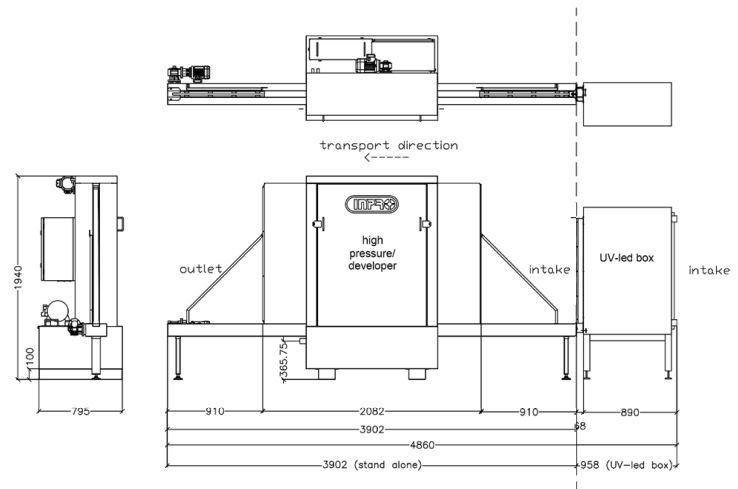

Maximum screen dimensions: 35 x 47 inches  
Transport chain speed: Variable up to 28 inches / min.  
Powerful highpressure pump: Variable up to 2200psi  
Screen input on right side & output on left side

