



Eliminator2 Door

Energy-Free Aluminum Frame Door



Eliminaator2 Door

Energy-Free
Aluminum Frame Door

Anthony's Eliminaator2 door eliminates all heat in freezer and cooler doors.

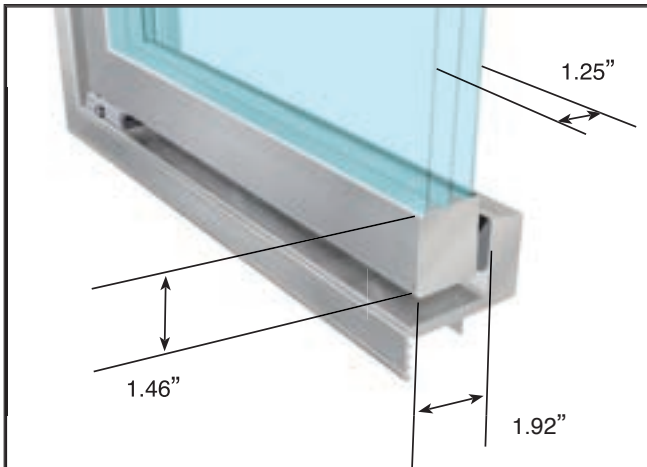

ELM2 - Energy-Free Aluminum Doors

Eliminaator2 Features

- Eliminates all heat in freezer and cooler doors
- Warm edge glass technology and anti-fog coating available
- Low-energy perimeter frame
- Optimax Pro 24 LED option provides up to 75% energy savings vs. fluorescent
- Dramatic energy savings = fast payback

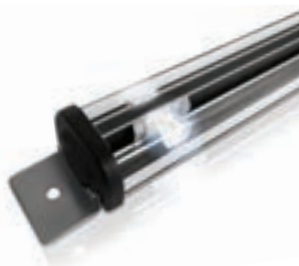

Optimax Pro 24 LED

CleanGrip
Handle



Slimline
Handle

Applications

Energy-Free Cooler and Freezer
Retrofit

Standard Features

Zero Heat in Cooler and Freezer Doors
Warm Edge Spacer Technology
Heat Reflective Low-e Glass
Hold-Open & Door Stop
Electrical Hinge Pin
Torque and Sag Adjust
Reversible Door Swing
Magnetic Door Gaskets for Tight Seal
Slimline Handle
ELS Lighting

Options

Pass-Thru Door Version
Optimax Pro 24 LED
Anti-Fog
Full Length Handle
SoftTouch Handle
CleanGrip Handle
Black, Satin Silver or Aluminum Finish
Cylinder Lock or POM Lock
French Door Frame
Extra/36" Deep/Custom Shelves
Double Wide Shelves
Black/White Epoxy-Coated Shelf Posts
Gravity Flow Shelving
Dampening Hold Open
Heated Glass

Reliability Features

500,000 cycle tested for wear
10-year warranted glass seal
12 months parts warranty
UL, cUL, NSF compliant

ELM2 01-14

For more information, call 800-772-0900, visit www.anthonyintl.com or email sales@anthonyintl.com

 **Anthony**
A DOVER COMPANY