



101 Series Door

Robust Energy-Efficient Aluminum Frame Door



101 Series Door

Robust Energy-Efficient Aluminum Frame Door

Anthony's Model 101 Series door sets high standards for energy efficiency and performance, providing superior thermal protection against condensation.

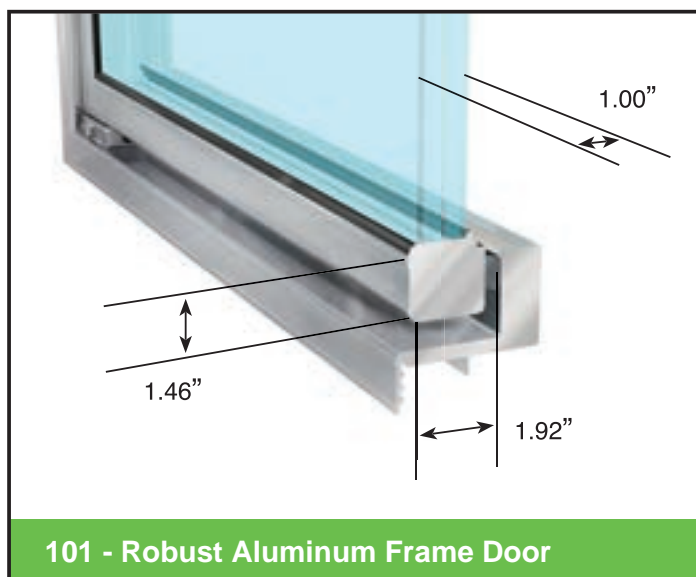

101 Series Features

- Insulated perimeter frames designed with forward-facing raceway
- Energy-efficient frame, reducing energy to the frame by 30%
- Narrow door rail (1-3/8")
- Insulated, fully-tempered door safety glass
- EISA (Energy Independence and Security Act) compliant



Slimline Handle



Optimax Pro 24 LED

Applications

Energy-Efficient Cooler and Freezer

Thermal Protection

Standard Features

Warm Edge Spacer Technology

Heat Reflective Low-e Glass

Hold-Open & Door Stop

Electrical Hinge Pin

Torque and Sag Adjust

Reversible Door Swing

Magnetic Door Gaskets for Tight Seal

Slimline Handle

27" Deep White Shelving

T-8 Lighting

Options

Pass-Thru Door Version

Optimax Pro 24 LED

Anti-Fog

Full Length Handle

Trimline Handle

SoftTouch/CleanGrip Handle

Black or Satin Silver Finish

Gold/Silver Smooth/Serrated Finish

Cylinder Lock or POM Lock

French Door Frame

Extra/36" Deep/Custom Shelves

Double Wide Shelves

Black/White Epoxy-Coated Shelf Posts

Gravity Flow Shelving

Dampening Hold open

Heated Glass

Reliability Features

500,000 cycle tested for wear

10-year warranted glass seal

12 months parts warranty

UL, cUL, NSF compliant