

Workshop manual
HTC DURATIQ T6, X6, T8, X8



English

Contents

1 Introduction

1.1 Document description.....	3
1.2 Target group.....	3
1.3 Revisions.....	3
1.4 Safety.....	3
1.5 Servicing tools.....	3

2 Safety

2.1 Safety definitions.....	4
2.2 General safety instructions.....	4
2.3 Special safety instructions.....	4
2.4 Electrostatic discharges (ESD) protection.....	4

3 Servicing data

3.1 Symbols in the diagrams.....	6
3.2 Tightening torques motor.....	7
3.3 Tightening torques grinding head.....	8
3.4 Tightening torques grinding head.....	9

4 Servicing tools

4.1 Servicing tools overview.....	10
4.2 Servicing tools overview.....	11
4.3 Servicing tools overview.....	12
4.4 Servicing tools overview.....	13

5 Prepare and do servicing on the product

5.1 To do a check of the firmware on the machine....	14
5.2 To download firmware.....	14
5.3 To do an update of the main circuit board.....	14
5.4 To do an update of the control panel.....	16
5.5 To do a pairing operation between the product and the remote control.....	17

6 Function overview

6.1 To clean and examine the product parts.....	18
6.2 Product overview.....	18
6.3 Component overview, grinding head.....	19
6.4 Overview, control panel on the product.....	19
6.5 Overview remote control	20
6.6 Overview of the receiver for the remote control...	21
6.7 Component overview, electrical enclosure.....	22
6.8 Overview, connection panel.....	22
6.9 Overview, battery charger.....	23
6.10 Display overview.....	24
6.11 CAN bus system.....	25

7 Repair and servicing

7.1 Motor.....	26
7.2 Tool holders	30
7.3 Grinding head.....	30
7.4 Radial shaft seal.....	34
7.5 Belt tensioner.....	35
7.6 Primary belt.....	37
7.7 Hub assemblies.....	38
7.8 Secondary pulley.....	43
7.9 Idle pulleys.....	48
7.10 S-key.....	50

8 Troubleshooting

8.1 General.....	51
8.2 The product does not start.....	51
8.3 The fuses break or the RCD opens frequently....	51
8.4 The product does not operate correctly.....	51
8.5 Error codes.....	52

9 Diagrams

9.1 Wiring diagram, electric box.....	54
9.2 Wiring diagram, main circuit board.....	55

1 Introduction

1.1 Document description

This manual gives a full description of how to do maintenance and repair on the product. It also gives safety instructions that the personnel must obey.

1.2 Target group

This manual is for personnel with a general knowledge of how to do repair and do servicing. All personnel that do repair or do servicing on the product must read and understand the manual.

1.3 Revisions

Changes to the product can cause changes to the maintenance work and spare parts. Separate information is sent out for each change.

Read the manual together with all received information about changes to maintenance and spare parts for the product.

1.4 Safety



WARNING: All personnel that repair or do servicing on the product must read and understand the safety instructions in this workshop manual.

1.5 Servicing tools

The manual gives information about necessary servicing tools. Always use original tools from HTC.

2 Safety

2.1 Safety definitions

Warnings, cautions and notes are used to point out specially important parts of the manual.



WARNING: Used if there is a risk of injury or death for the operator or bystanders if the instructions in the manual are not obeyed.



CAUTION: Used if there is a risk of damage to the product, other materials or the adjacent area if the instructions in the manual are not obeyed.

Note: Used to give more information that is necessary in a given situation.

2.2 General safety instructions

- Read and obey this workshop manual.
- Obey the local safety regulations when you repair or do servicing of the product.
- The safety equipment you use must obey local regulations.
- Use only the equipment that the manufacturer recommends.
- Use personal protective equipment.
- Use protective gloves and safety glasses. The safety glasses must obey the ANSI Z87.1 for US or EN166 for EU countries.
- Use earmuffs when the product is in operation.
- Always stop the product before you repair or do servicing of the product.
- Remove flammable materials from the work area. The product can cause sparks.
- Do not use the product if the power cord or cables are damaged.
- Disconnect the product from the mains socket.
- If possible, keep the power cord disconnected when you repair or do servicing of the product.
- Use cables adapted to outdoor operation.
- Do not touch the wires when the product is on. An electrical shock can cause injury.
- Do not point compressed air to your body. Compressed air can go into the blood stream.
- Always tighten the nuts and the bolts on the product correctly.
- Do not use the power cord to lift the product. Do not pull the power cord to disconnect the product.
- Do checks of the product for warning labels that are damaged. Replace the warning labels that are damaged.
- Always read the warning labels of product supplies.
- Obey the local waste regulations.

2.3 Special safety instructions

The product has 2 emergency stop buttons. 1 emergency stop button is on the control panel and 1 is on the remote control.

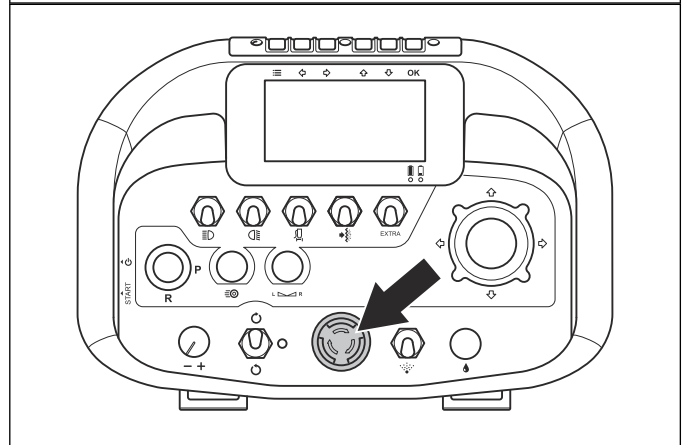
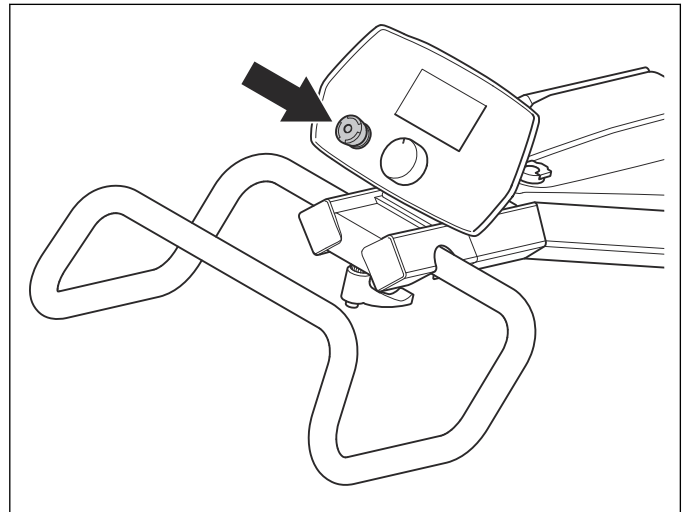

WARNING: Voltage stays in the product after the emergency stop button is pushed.

2.4 Electrostatic discharges (ESD) protection



CAUTION: Electrostatic discharges can cause damage to the product.

Most semiconductors, such as electrical enclosures, radio units, control panels, and drive motors are sensitive to electrostatic discharges (ESD). Parts of different materials that are rubbed against each other in the product can cause electrostatic charges. When a charged part is touched, there is an electrostatic discharge. The electrostatic discharge can cause damage to the sensitive semiconductors.

There are different accessories that can make sure that electrostatic discharges do not occur to the components:

- Antistatic bags to send the components in. In the bags, components are safe from external discharges.
- Conductive mats and wristbands connected to the ground are used at workplaces. They give the

workplace and the persons at the workplace, equal voltage to the ground. Conductive mats and wristbands prevent electrostatic discharge when a charged part is touched.

- It is recommended to use ESD shoes.

2.4.1 To prevent electrostatic discharge during servicing

- Always use ESD wristbands.
- Make sure that workbenches and storage areas for used components have ESD protection.

3 Servicing data

3.1 Symbols in the diagrams



Tightening torque, Nm

3.2 Tightening torques motor

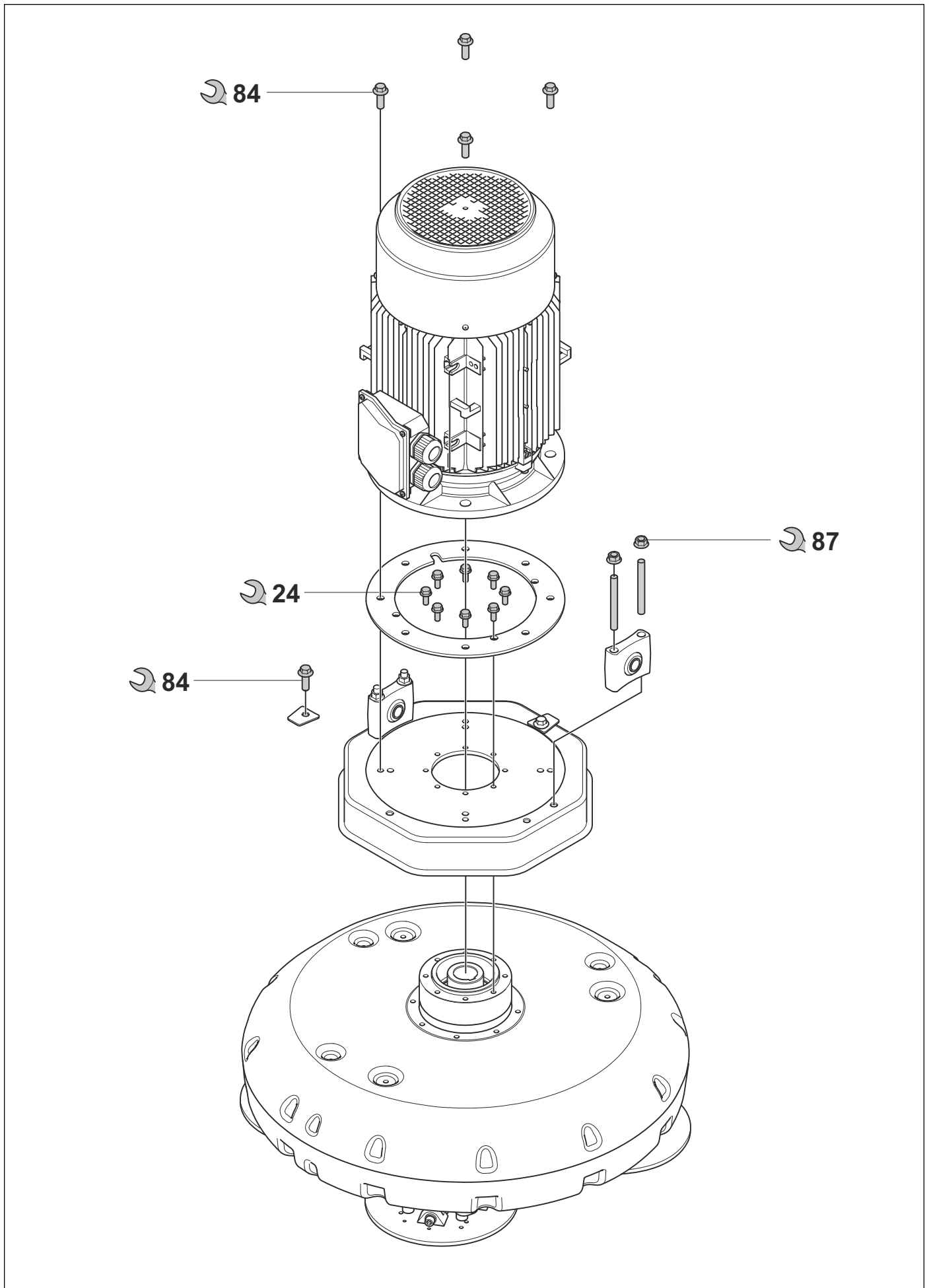

3.3 Tightening torques grinding head

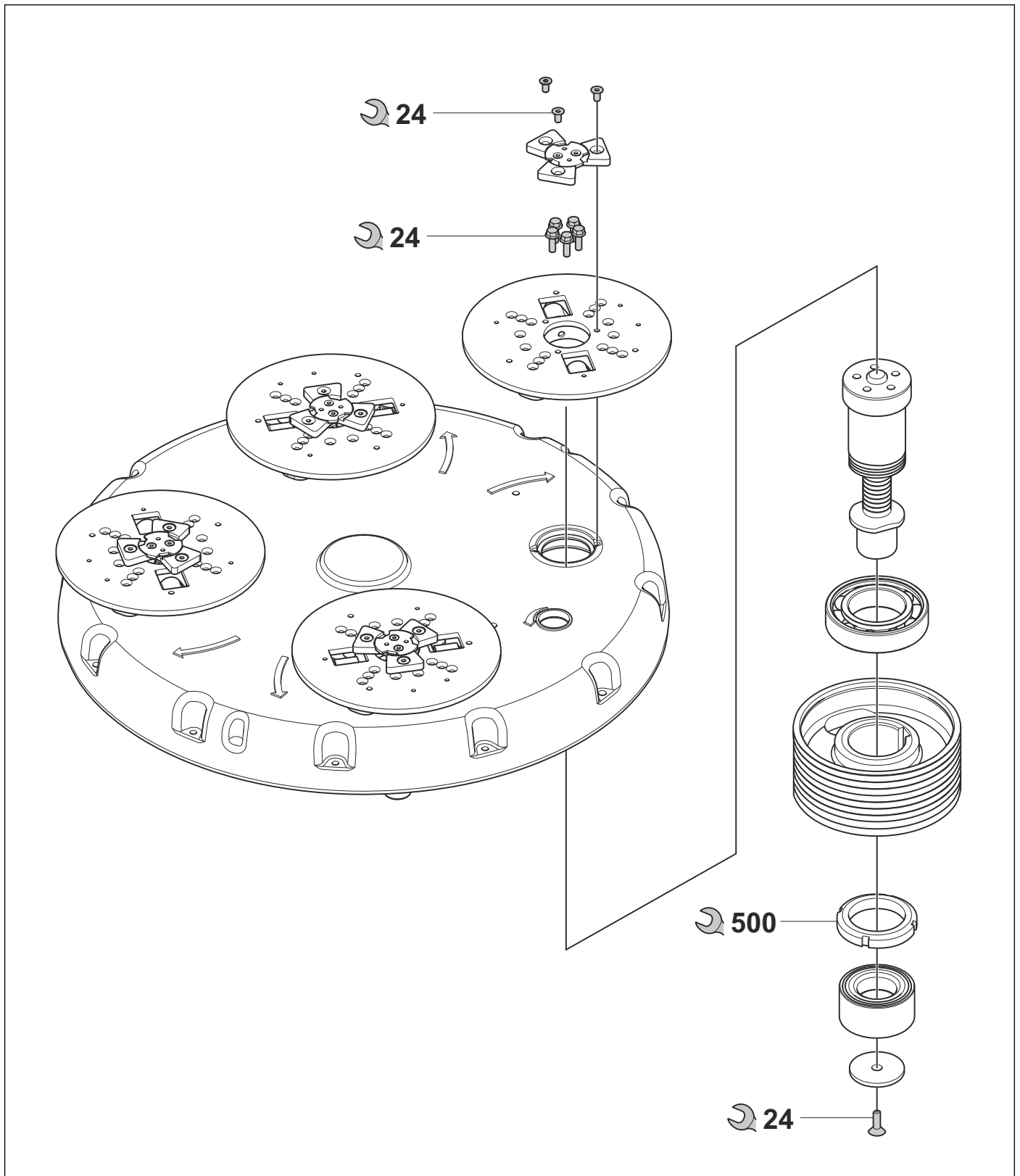

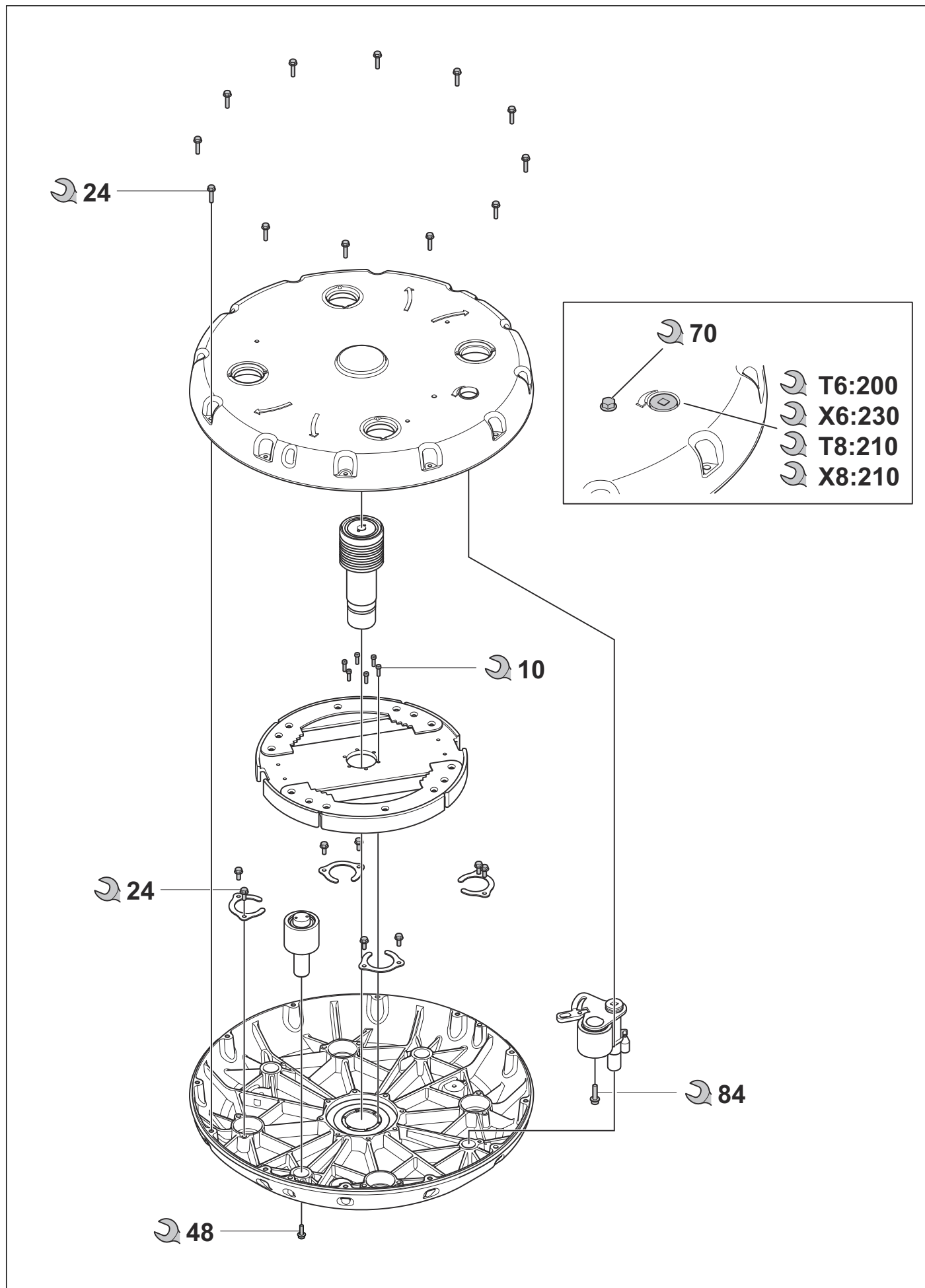

3.4 Tightening torques grinding head

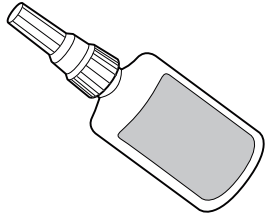

4 Servicing tools

4.1 Servicing tools overview

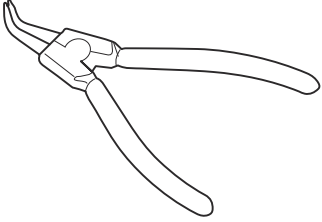
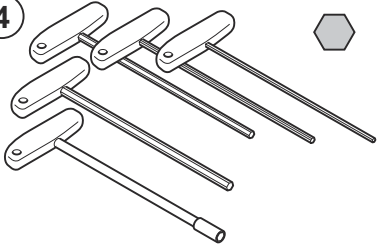
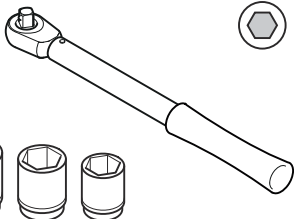
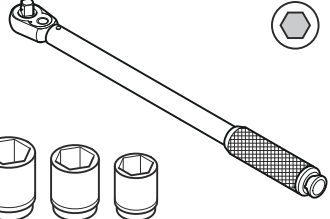
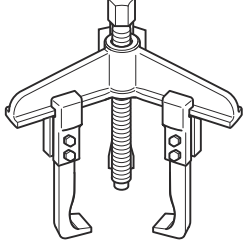
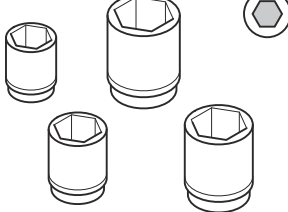
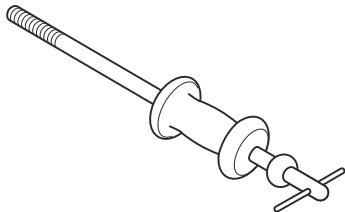
			
			
			
Position	Designation	Used for	Order No./Source
1	Adhesive for threads	–	Loctite®
2	Grease	To assemble the motor and grinding head.	Molykote W2 Multi-purpose grease
3	Circlip pliers	General	–
4	Hex key, kit 2.5 - 10 mm	General	525 45 52-01
5	Socket wrench	General	531 11 95-32
6	Torque wrench 11- 110 Nm	General	–
7	Inner puller	To remove the bearing housing from the motor plate	There are many manufacturers, for example, KUKKO.
8	Socket 8-18mm	General	–
9	Slide hammer	To remove the hub assembly	584 39 99-01

4.2 Servicing tools overview

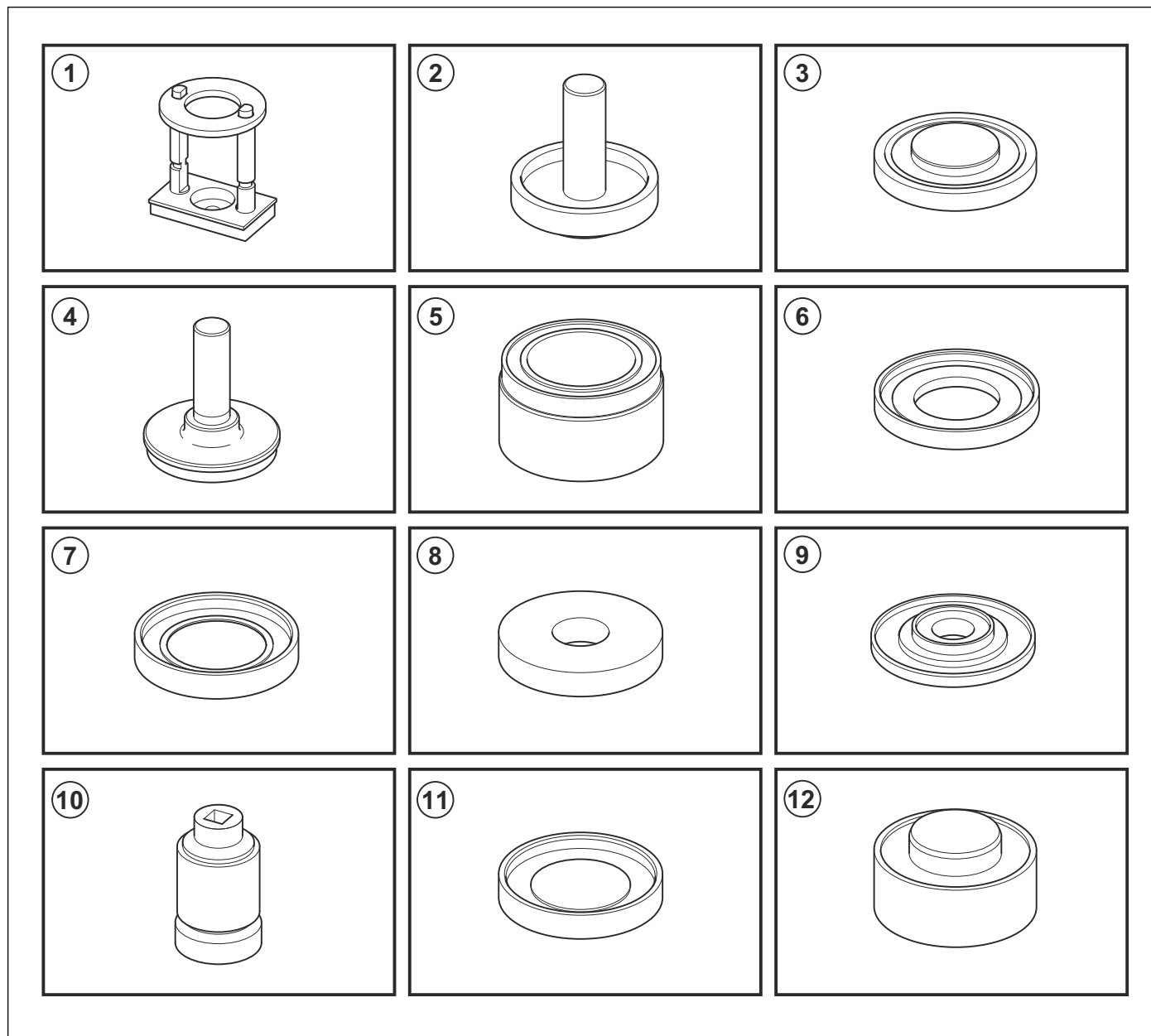

Position	Designation	Order No./Source
1	Hub pulley tool	593 53 68-01
2	Press tool for the inner hub	593 54 09-01
3	Press tool for the outer center hub	595 75 94-01
4	Press tool for the radial seal	593 54 11-01
5	Press tool for the upper center hub	593 54 12-01
6	Press fixture for the center hub	593 54 13-01
7	Press tool for the center pulley	593 54 14-01
8	Press tool for the hub assembly	593 54 15-01
9	Press fixture for the hub assembly	593 54 16-01
10	Socket KM 10 clearance 90	593 54 17-01
11	Press tool for the hub	593 54 18-01
12	Press tool for the idler	593 54 19-01

4.3 Servicing tools overview

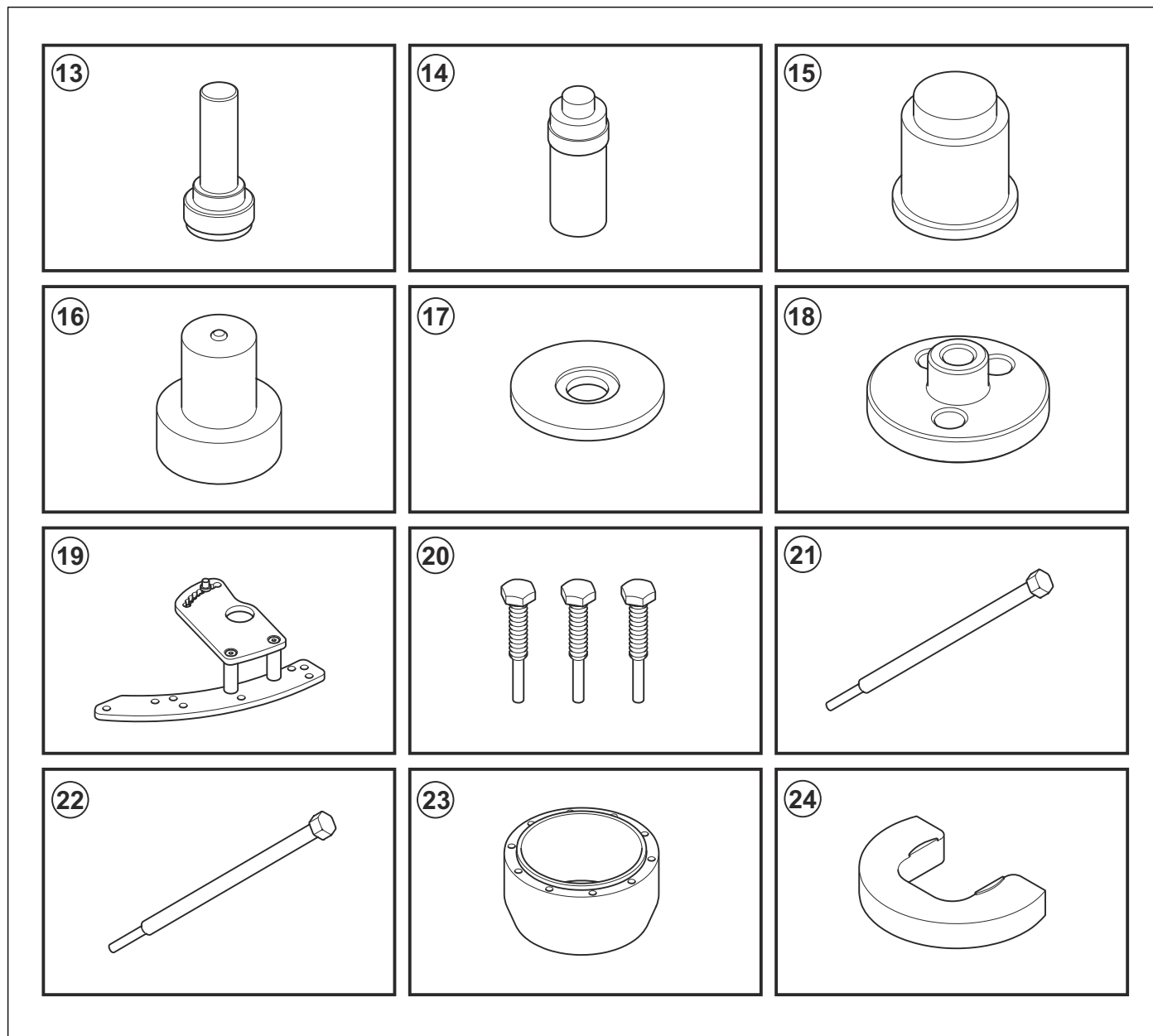

Position	Designation	Order No./Source
13	Press tool for the radial seal	593 54 21-01
14	Press tool for the center hub	593 54 40-01
15	Press tool for the center pulley	593 54 41-01
16	Press tool for the hub assembly	593 54 42-01
17	Support for the hub assembly tool	593 54 43-01
18	Removal tool for the hub assembly	593 58 39-01
19	Belt tension fixture	593 58 40-01
20	Tool for disassembly of the grinding head	593 54 45-01
21	Removal tool for the 15 kW motor	595 76 16-01
22	Removal tool for the 7.5 kW motor	595 76 15-01
23	Support cone for the center hub assembly	593 54 51-01
24	Fixture for the center pulley bearing	593 54 52-01

4.4 Servicing tools overview

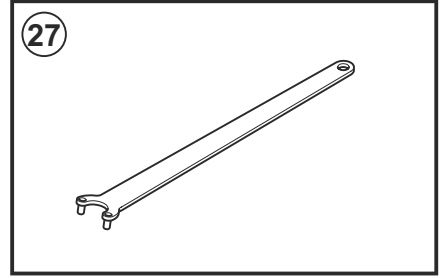
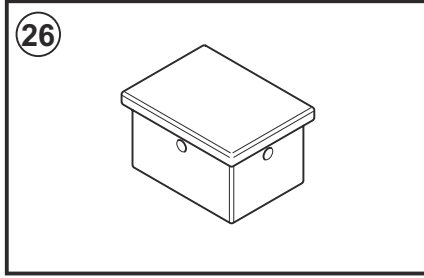
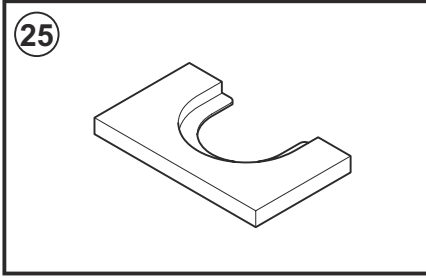

Position	Designation	Order No./Source
25	Press tool for the hub assembly	593 54 30-01
26	Tilt support	593 58 41-01
27	Pin wrench	593 63 27-01

5 Prepare and do servicing on the product

5.1 To do a check of the firmware on the machine

1. Open the menu on the control panel.
2. Select "Service" and press "OK".
3. Select "Control Panel".
4. Do a check of the "Version Firmware".
5. Go back and select "Expansion board".
6. Do a check of the "Version Firmware".

5.2 To download firmware

1. Format 2 USB memory sticks to FAT32.

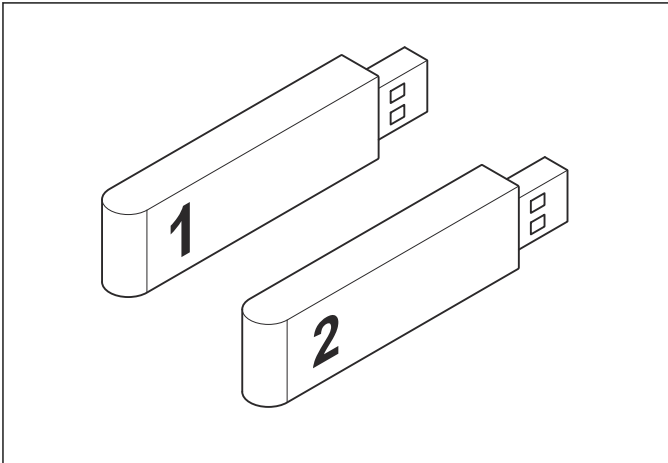

2. Download the correct firmware from the support site.

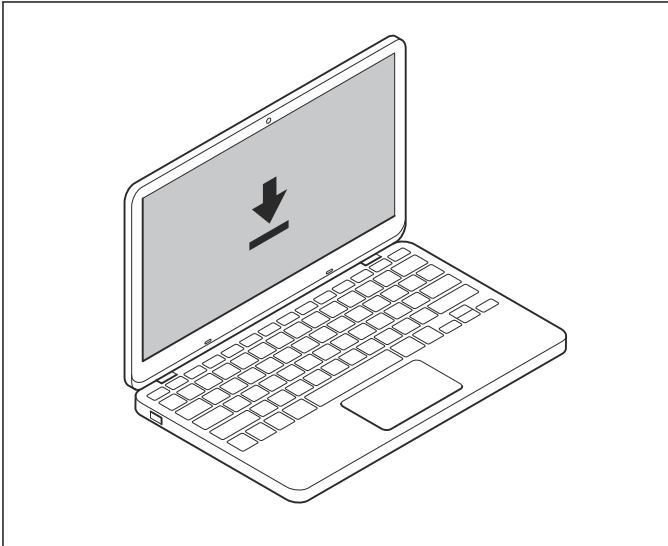

3. Put the firmware for the main circuit board on USB 1 and put the control panel firmware on USB 2.

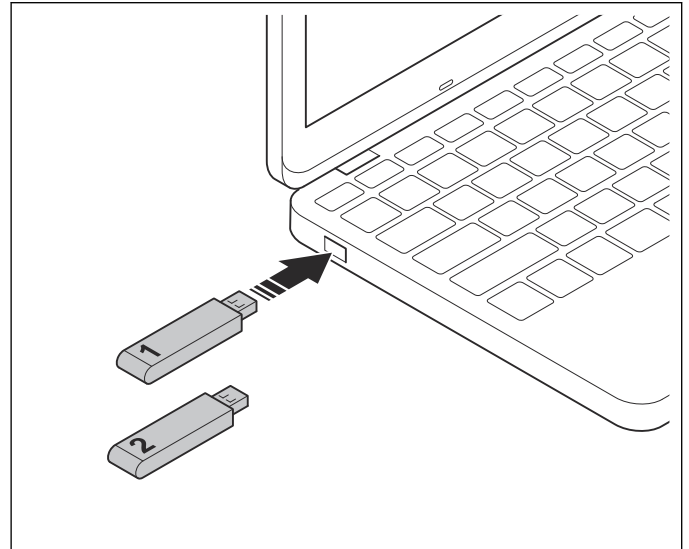

5.3 To do an update of the main circuit board

1. Stop the power.
 - a) Turn the battery switch counterclockwise.

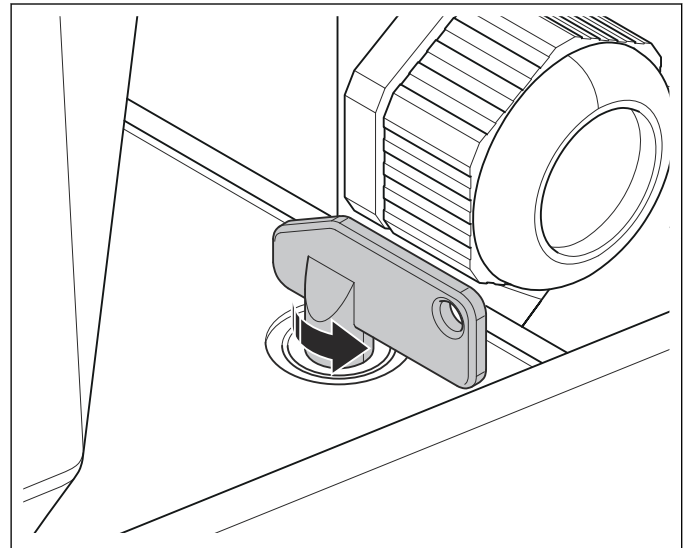

b) Move the fuse switches down.

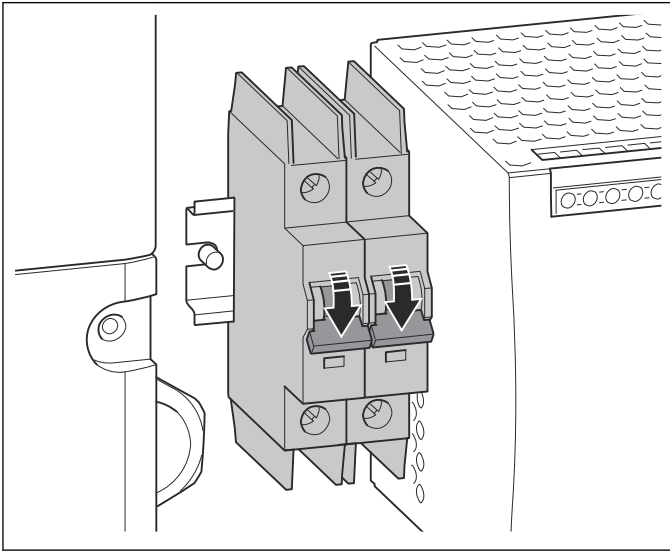

4. The LED on the main circuit board starts to flash.

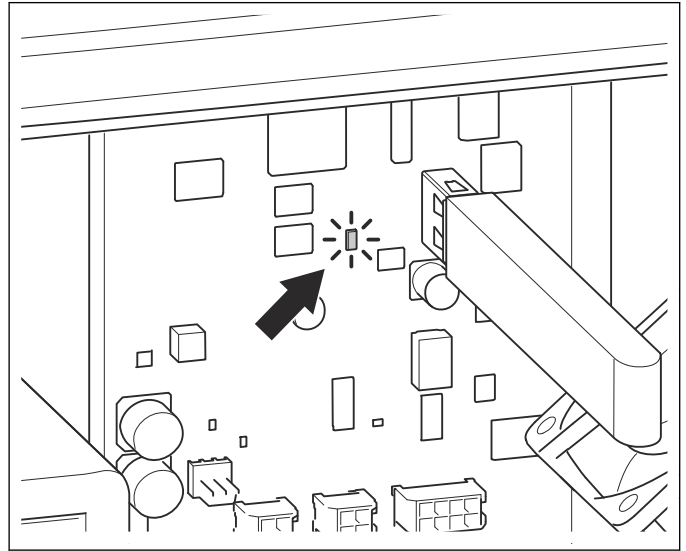

2. Put a USB memory stick into in to the USB connector on the main circuit board.

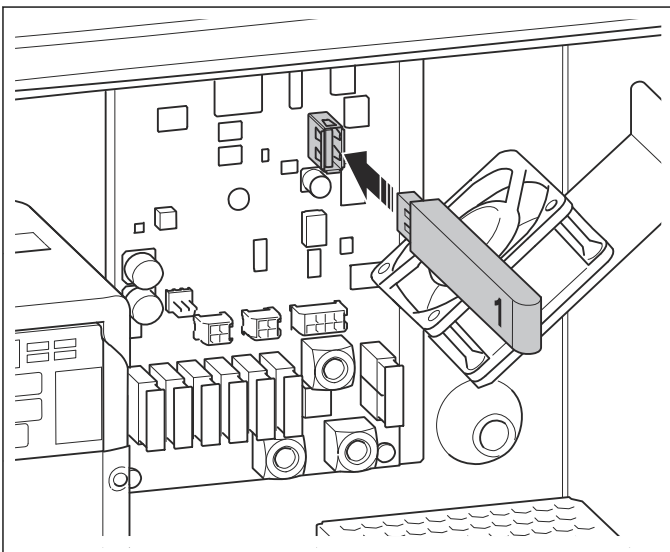

5. When the LED goes off, move the fuse switches down to stop the power.

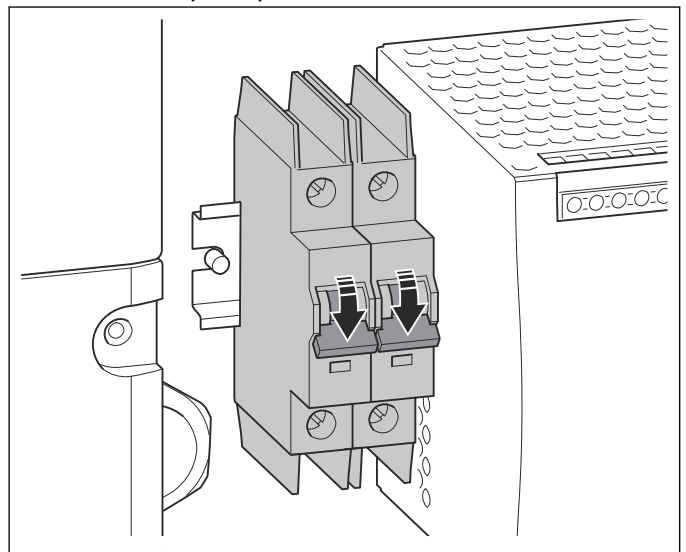

3. Move the fuse switches up to start the power.

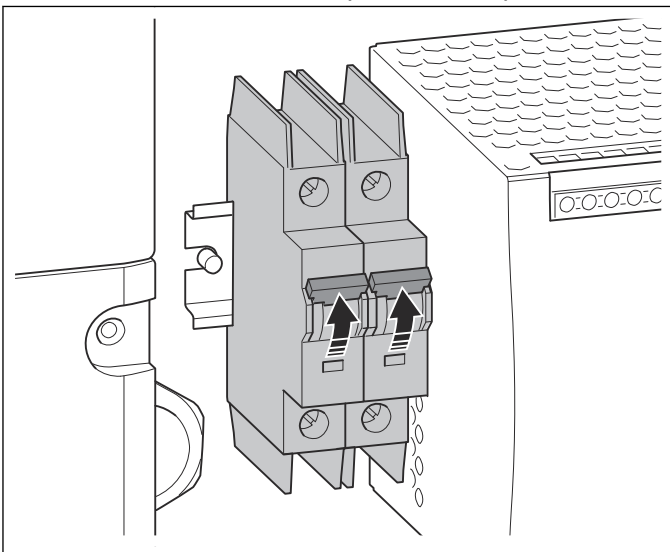

6. Remove the USB memory stick from the main circuit board.

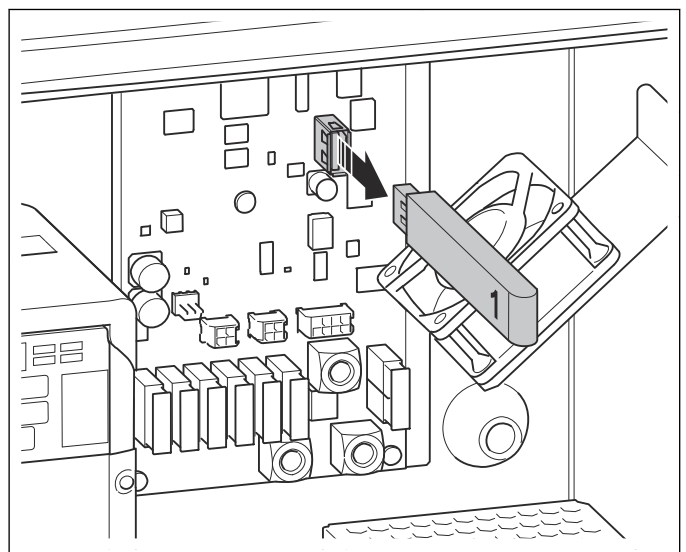

7. Start the power.

a) Move the fuse switches up.

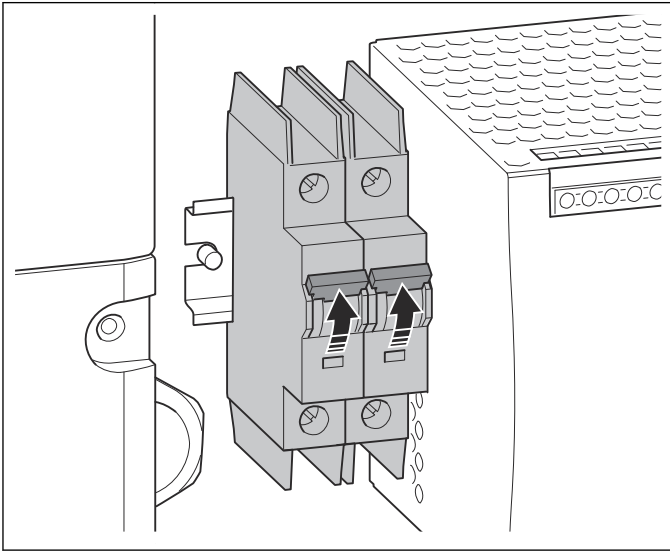

b) Push the stop button on the control panel.

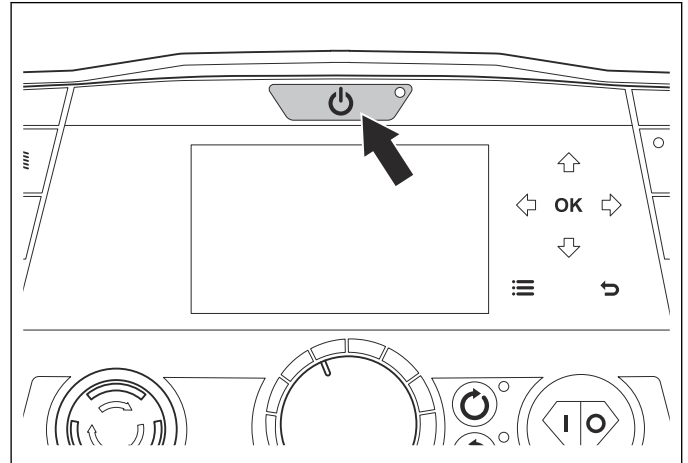

b) Turn the battery switch counterclockwise.

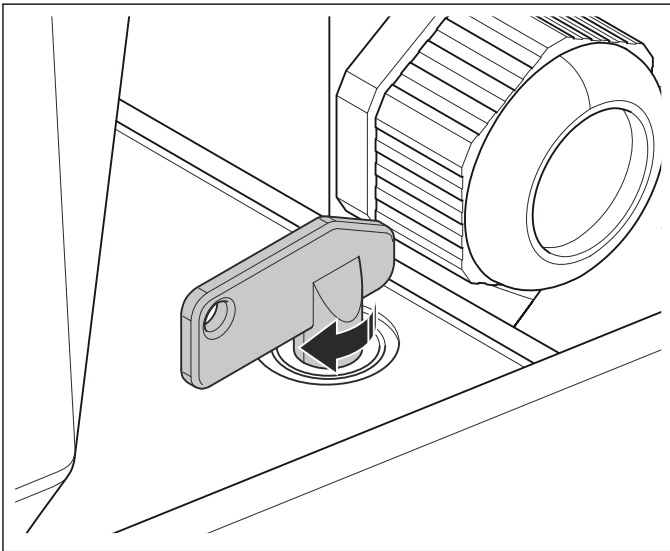

2. Put the USB memory stick in to the USB connector on the control panel.

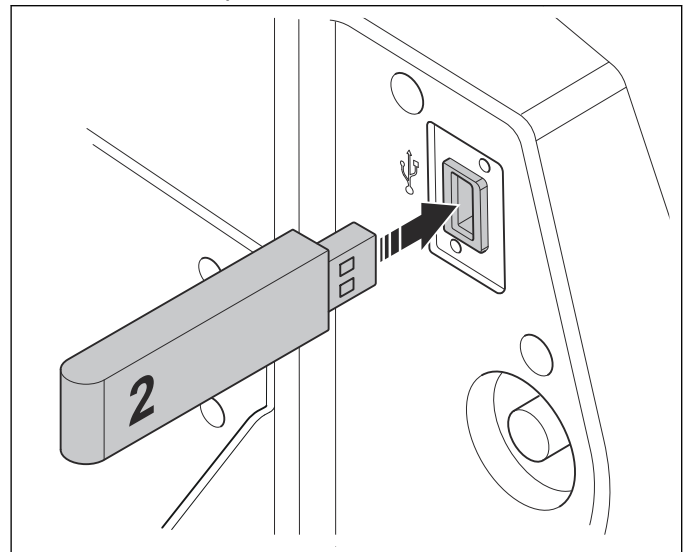

3. Start the control panel.

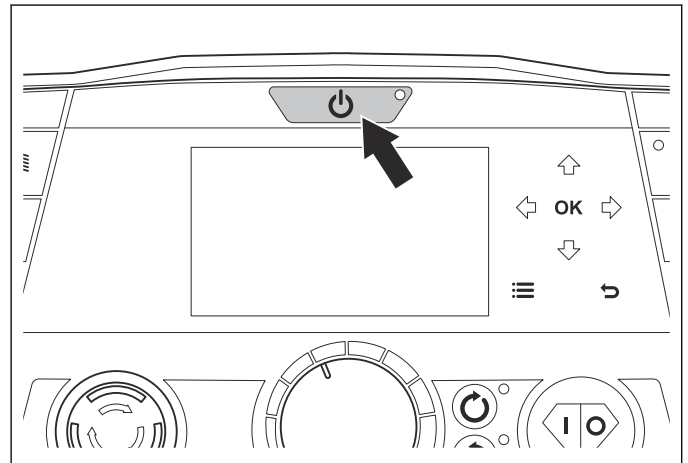

5.4 To do an update of the control panel

1. Stop the power.

a) Turn the battery switch counterclockwise.

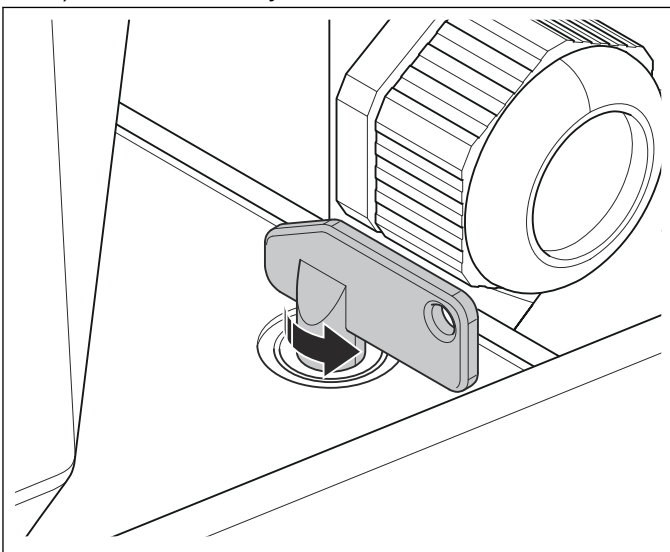

4. The LED starts to flash.

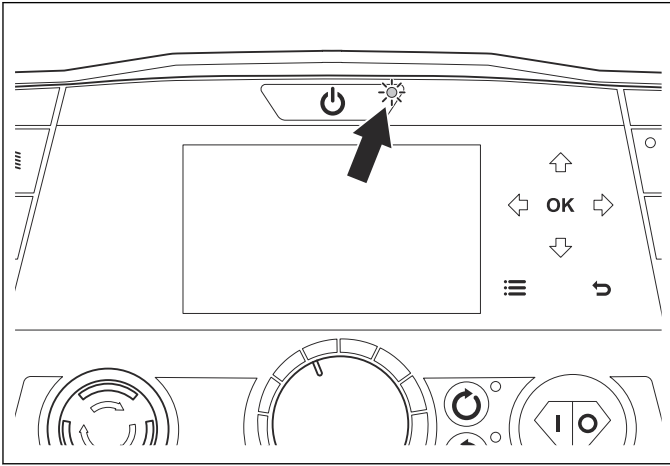

5. When the LED stop flash, remove the USB memory stick.

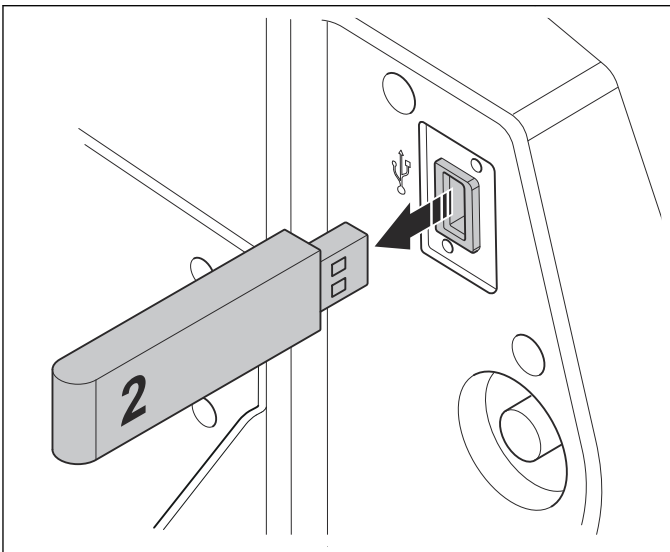

6. Go to "Service" and press "OK".
7. Press "OK".
8. Select "Service Settings" and press "OK".
9. If the update is not done correctly, select "Reinit set", press "OK" and do the update procedure again.

5.5 To do a pairing operation between the product and the remote control

1. Push the radio button on the control panel.

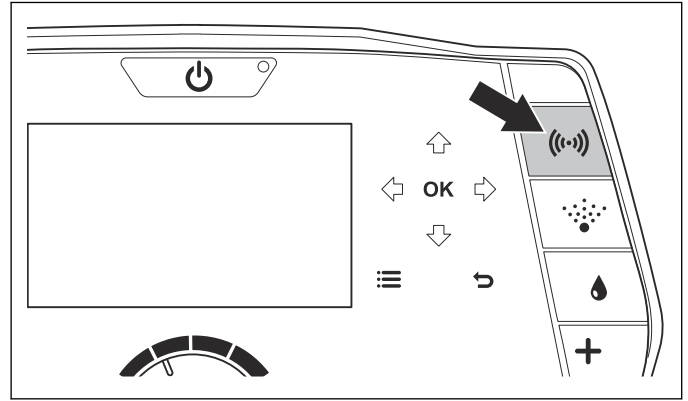

2. Push the green button.

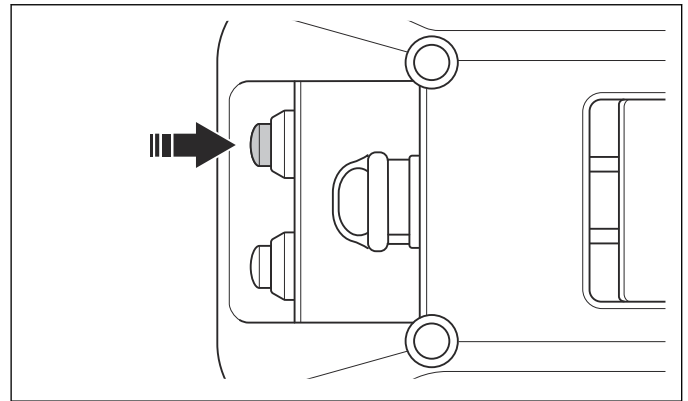

3. The symbol on the display and the LED on the radio button start to flash.

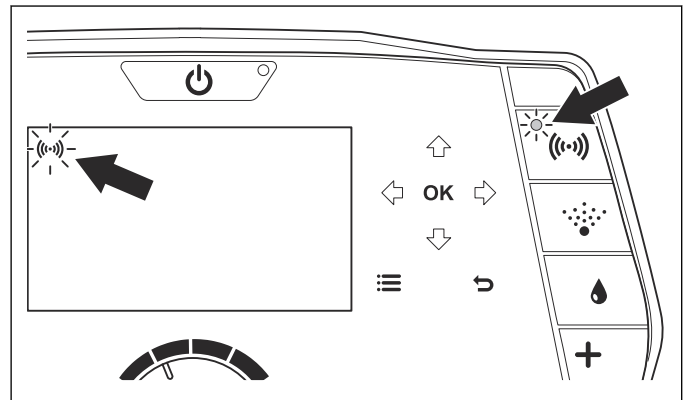

4. When the LED has a constant light and the symbol does not flash, the pairing operation is completed.

6 Function overview

6.1 To clean and examine the product parts

- Clean and examine all parts fully. You find more instructions in the chapter for each part if special tools or procedures are necessary.

- Replace damaged or defective parts.
- Always use original spare parts.

6.2 Product overview

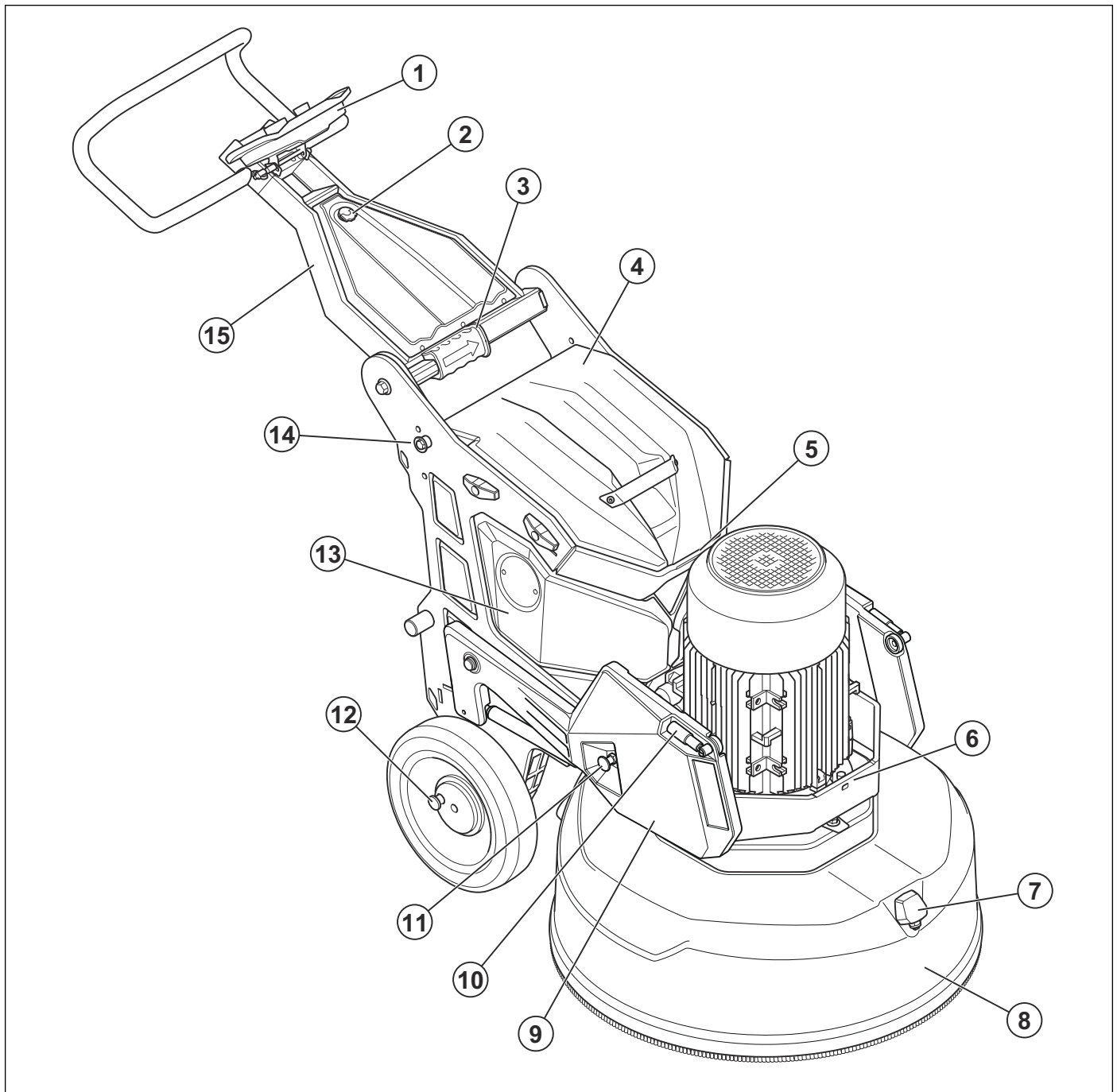

- | | |
|---|---|
| 1. Control panel | 9. Weight |
| 2. Storage hatch | 10. Weight handle |
| 3. Lock knobs for rough adjustment of handlebar | 11. Weight lock |
| 4. Storage hatch | 12. Wheel lock |
| 5. Lifting point | 13. Inspection hatch |
| 6. Hole to attach the support wheel | 14. Lock knobs for small adjustments of handlebar |
| 7. Nozzle for mist cooler system | 15. Handle |
| 8. Grinding head | |

6.3 Component overview, grinding head

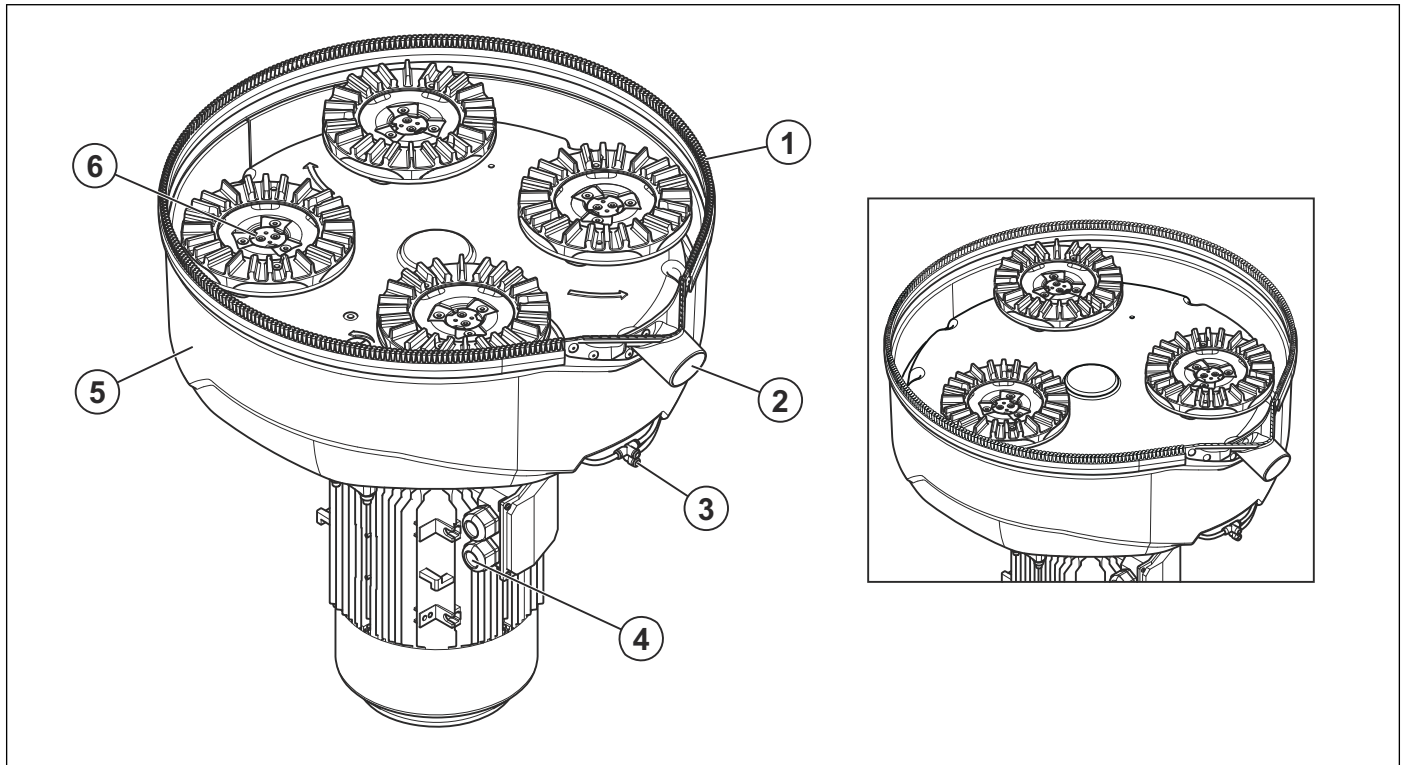

- | | |
|-----------------------------------|------------------------|
| 1. Brush strip | 5. Grinding head cover |
| 2. Connection, vacuum hose | 6. Tool plate |
| 3. Connection, mist cooler system | |
| 4. Cable connection | |

6.4 Overview, control panel on the product

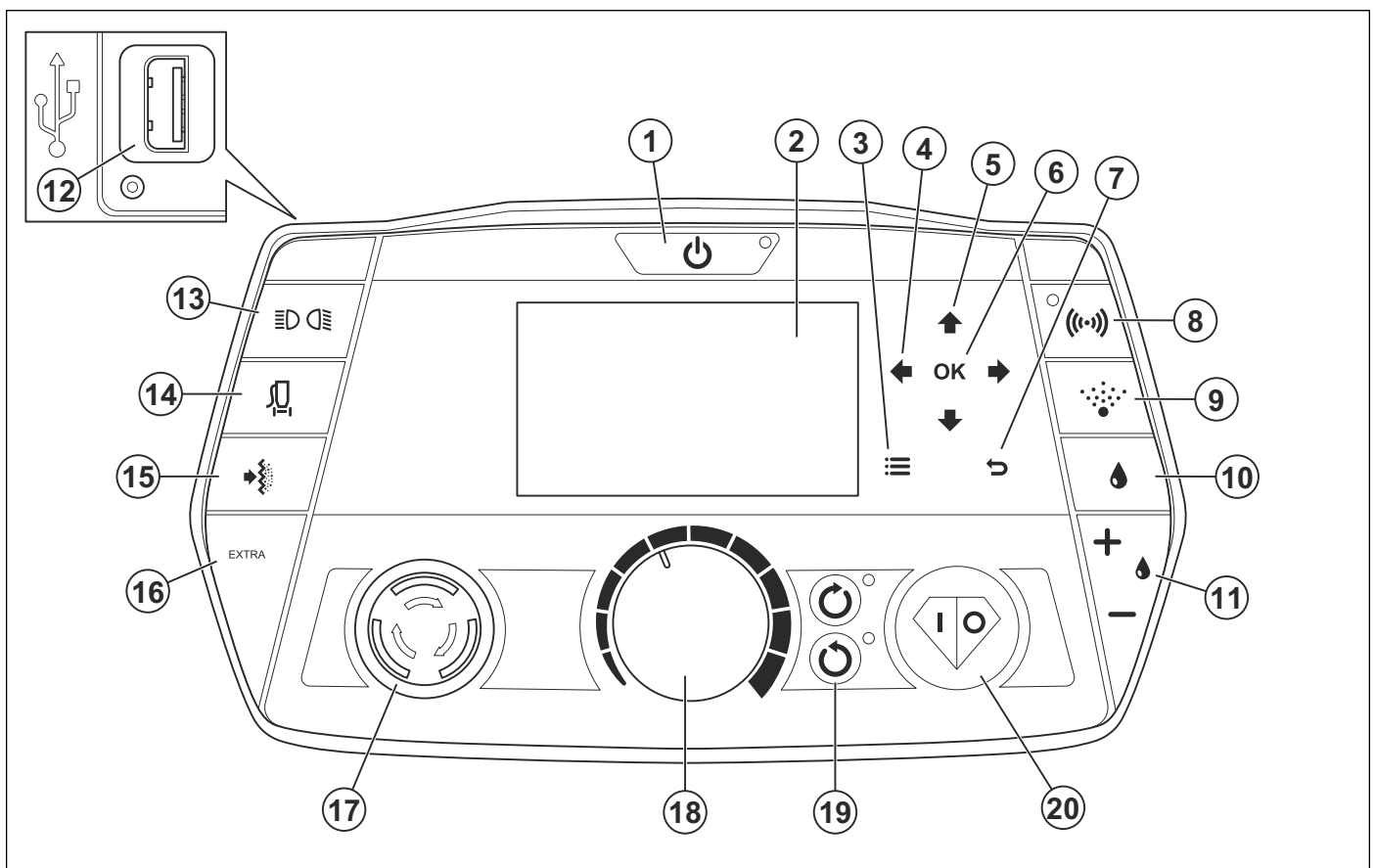

- | | |
|---|---|
| 1. ON/OFF button for the product. | 4. Move right/left in the menu and change the information that the operation gauge shows. |
| 2. Display, refer to <i>Display overview on page 24</i> . | 5. Move up/down in the menu and set night panel ON/OFF. |
| 3. Open menu. | |

6. "OK" for approval of menu selections. To reset distance gauge, press some seconds.
7. Go back in the menu structure.
8. Set radio communication ON/OFF.
9. Set mist cooler system ON/OFF.
10. Set water supply ON/OFF.
11. Increase and decrease water supply.
12. USB port to charge mobile devices.
13. Lights: 1. All lamps come on. 2. Front lamps come on. 3. Rear lamps come on. 4. All lamps go off.
14. Start and stop the dust extractor.
15. Clean the filter: Quickly press on the button to clean 1 filter. Hold in the button to do a dust drain.
16. "EXTRA": ON/OFF.
17. Emergency stop button.
18. Increase or decrease the grinding head speed.
19. Change direction of rotation of the grinding head.
20. Start/Stop the grinding head.

6.5 Overview remote control

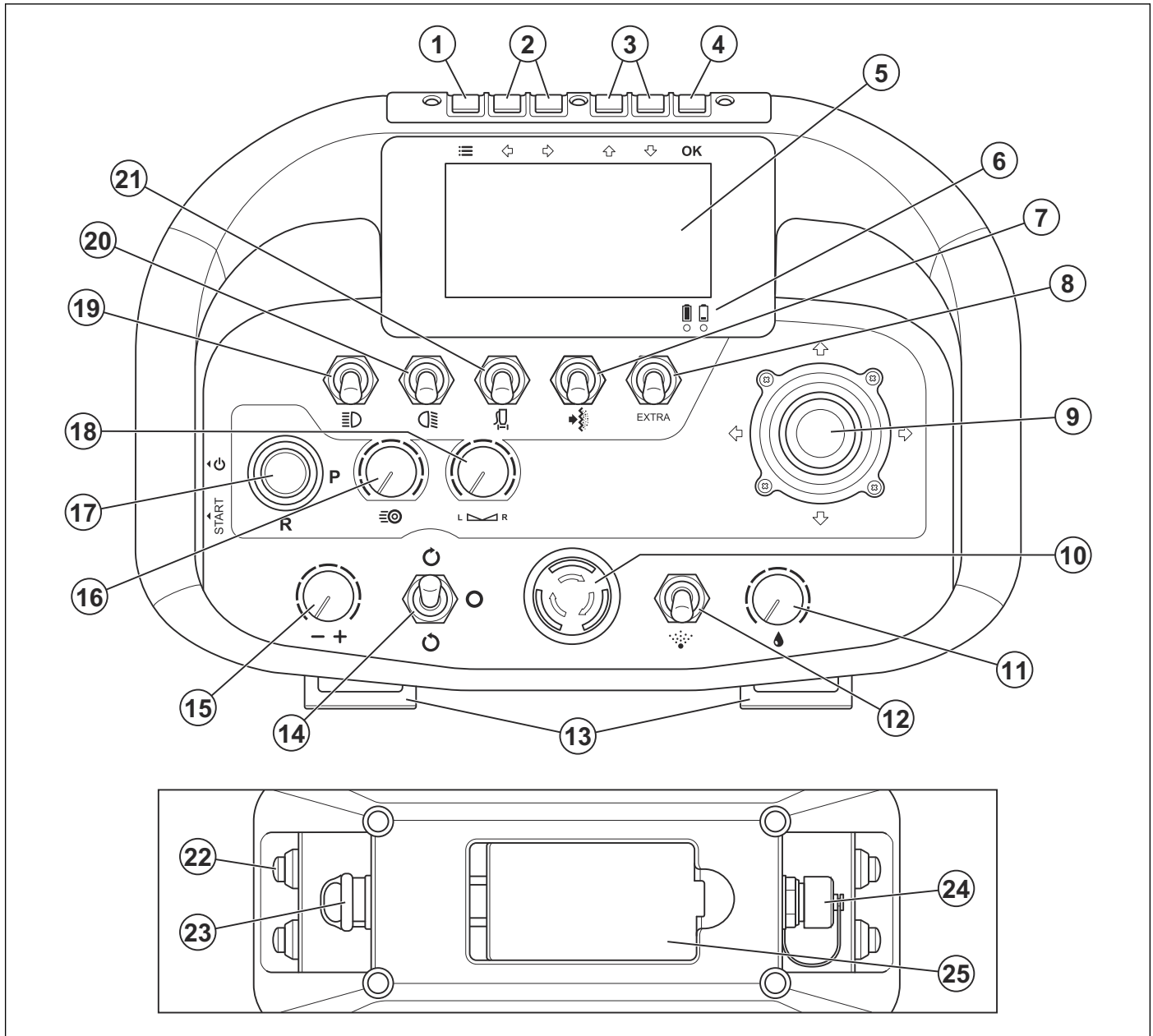

1. Menu button for future functions.
 2. Move right/left in the menu and change the information that the operation gauge shows.
 3. Move up/down in the menu and change the screen saver.
 4. Menu button for future functions.
 5. Display, refer to *Overview of the receiver for the remote control on page 21*.
 6. Status indicator.
- LED is off: The remote control is off.
 - Green LED flashes quickly: The remote control is not connected to the product.
 - Green LED flashes slowly: The remote control is connected to the product.
 - Red LED is on: The emergency stop is engaged or there is a fault on the remote control.
 - Red LED flashes: The battery state of charge is low.

7. Clean the filter: Quickly press on the button to to clean 1 filter. Hold in the button to do a dust drain.
8. "EXTRA" : ON/OFF.
9. Joystick. Steers the product left/right and controls the speed and direction of rotation of the grinding head.
10. Emergency stop button.
11. Increase and decrease water supply.
12. Set mist cooler system ON/OFF.
13. Bracket for harness.
14. Control for the grinding head. Left/right or stop.
15. Increase or decrease the grinding head speed.
16. Increase or decrease the movement speed of the product.
17. Control for direction. D: forward, R: rearward, P: parking brake.
18. Control the left/right deviation of the product when it is in operation.
19. Front lamps, ON/OFF.
20. Rear lamps, ON/OFF.
21. Start and stop the dust extractor.
22. Start radio communication between the remote control and the grinder.
23. Remote control ON/OFF and key code for the radio unit.
24. Socket for cable control.
25. Battery.

6.6 Overview of the receiver for the remote control

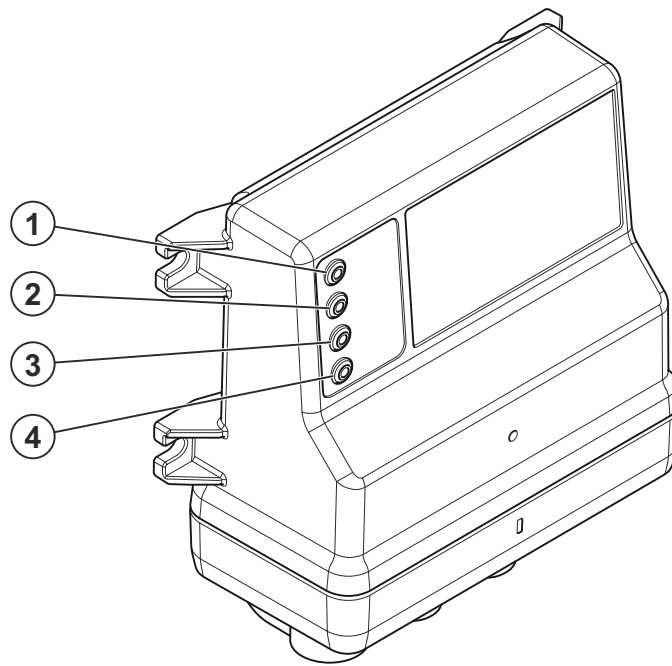

Position	LED	LED signal	Description
1	"POWER"	Off	The receiver has no power.
		On	The receiver has power but has no connection to the remote control.
		Flashes	The receiver has power and is connected to the remote control.
2	"ALARM"	Off	The receiver operates correctly.
		On	Something is defective.
		Flashes	Fault in emergency stop circuit.
3	"RUN"	Off	The CAN network is not in operation.
		On	The receiver does not use the CAN bus.
		Flashes	The receiver is connected to the CAN bus network.
4	"ERR"	Off	The CAN bus operates correctly.
		On	The CAN bus is not connected to the CAN bus network.
		Flash	The CAN bus is defective.

6.7 Component overview, electrical enclosure

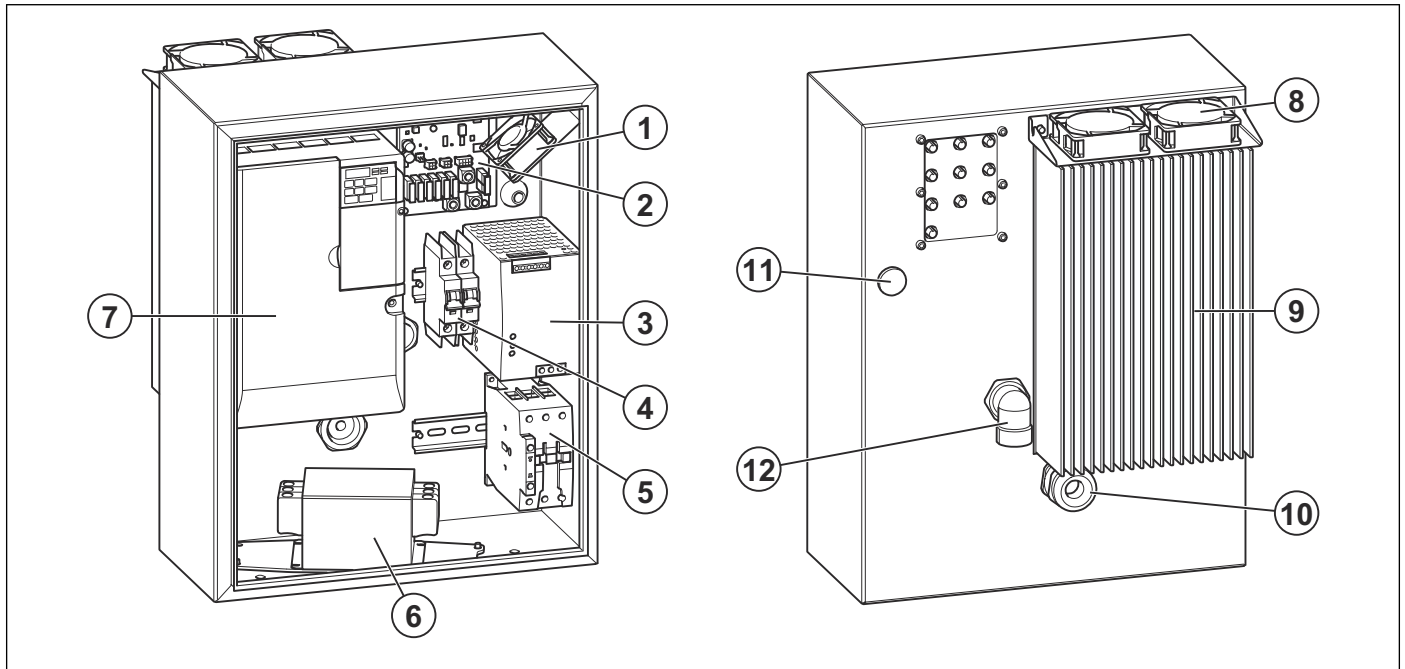

1. Fan 24V DC
2. Main circuit board
3. Power supply
4. MCB
5. Switch
6. EMC filter
7. Frequency inverter

8. Fan package heatsink
9. Heatsink
10. Motor cable
11. Power cord
12. Plug M20

6.8 Overview, connection panel

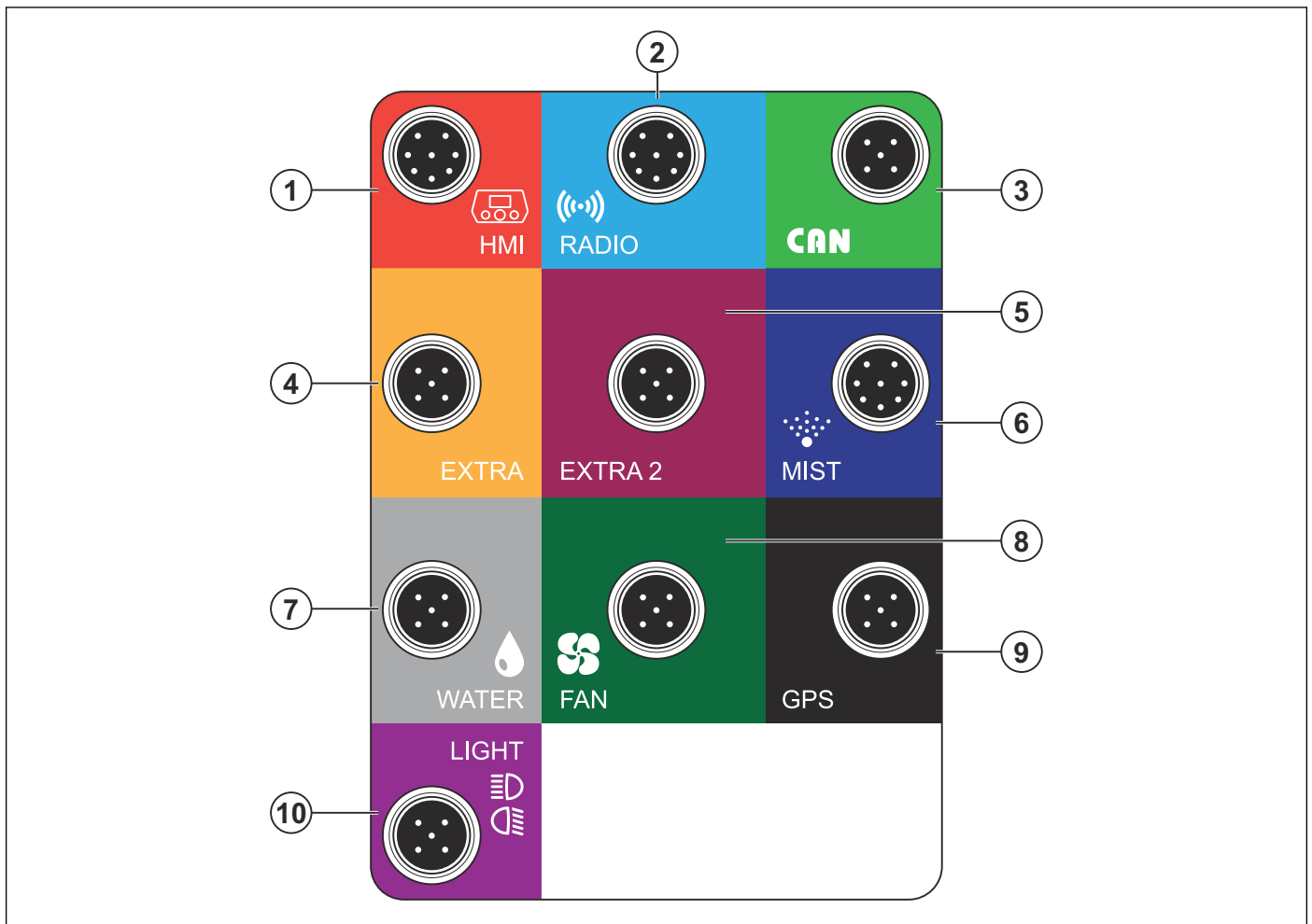

1. Control panel.
2. Radio unit receiver.
3. CAN bus.
4. Other equipment, 24 V.
5. Other equipment 2. Used for future equipment.
6. Mist cooler system.
7. Water supply valve.
8. Cooling fans.
9. GPS.
10. Work lighting.

6.9 Overview, battery charger

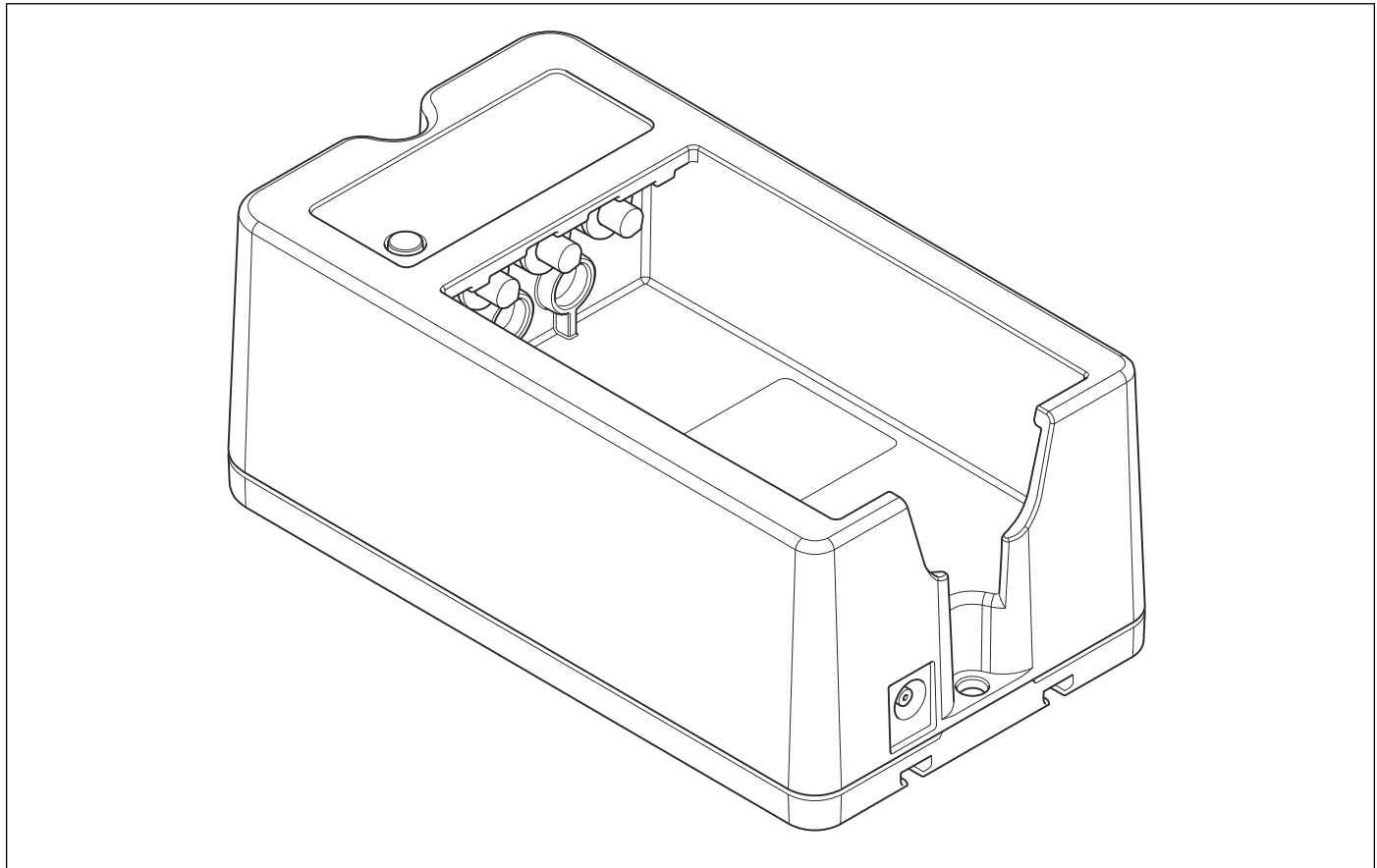

Symbol	Signal	Description
	Flashes slowly	The battery charger is energized. The battery is not correctly installed.
	Constant light	The battery charges.
	Flashes quickly	The battery is fully charged.

6.10 Display overview

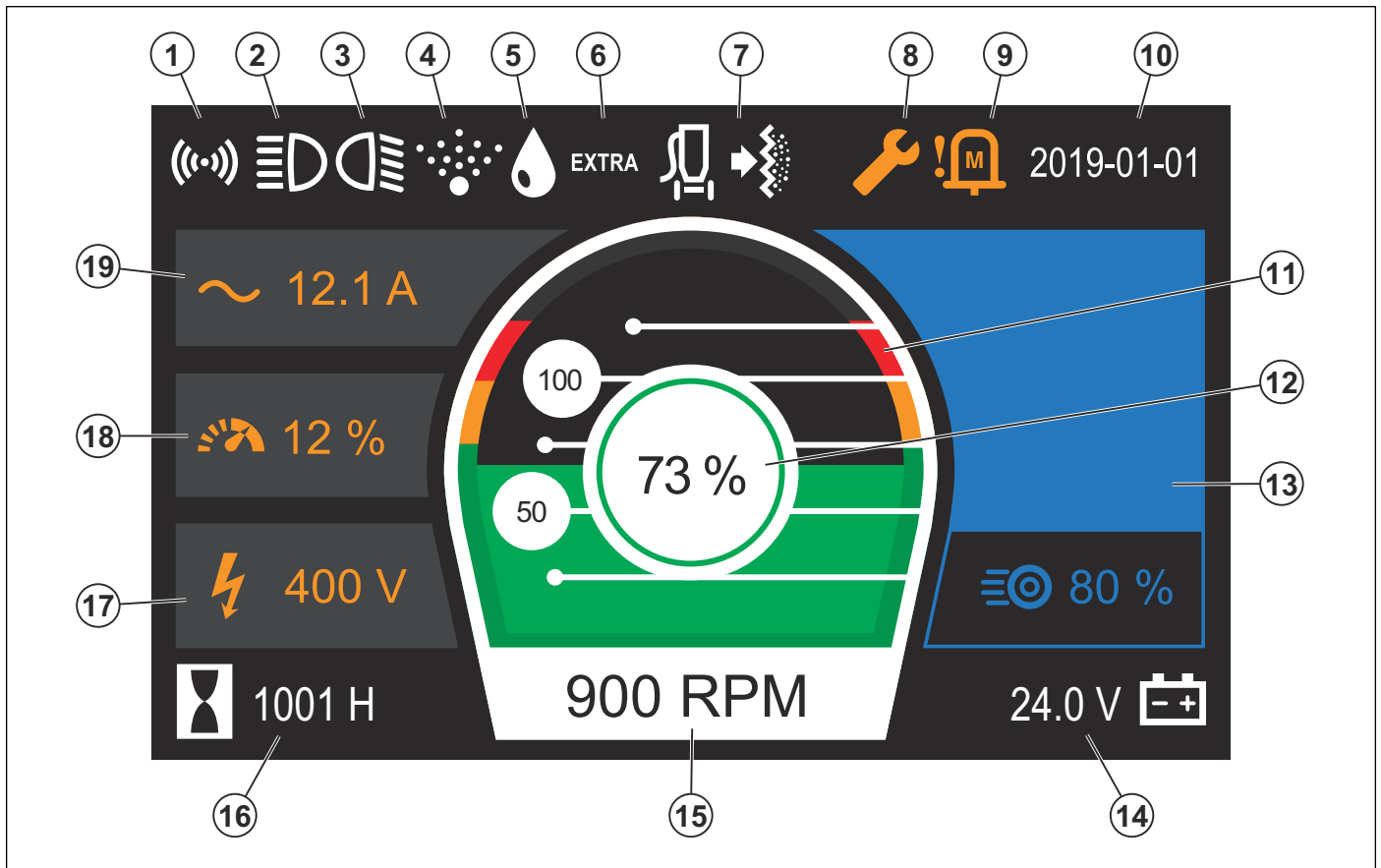

1. The remote control is connected.
2. The front light is on.
3. The rear light is on.
4. The mist cooler system is on. Yellow symbol: the water level in the water tank is low.
5. The water supply is on.
6. The output "EXTRA" is on.
7. Vacuum cleaner. Gray symbol: The product and the vacuum cleaner are connected. White symbol: The vacuum cleaner is on. The symbol flashes yellow: Warning. The symbol flashes red: Refer to *Error codes on page 52*.
8. Servicing. Orange symbol: Servicing is necessary in the next 50 hours or 2 weeks. Red symbol: Servicing is not done in time.
9. A symbol comes on when a warning or fault occurs. Refer to *Error codes on page 52*.
10. Time and date.
11. Shows the quantity of power available.
12. Power meter. The power level indicator and the ring around it change color. Green: The power level is 0-100%. Yellow: The power level is 100-115%. Red: The power level is more than 115%.
13. Water flow 0-100%. Forward speed 0-15 m/min.
14. Battery voltage when the machine is operated on batteries only.
15. Rotation speed of the grinding discs.
16. Operation gauge. Shows time of operation (h), distance (m) or energy (kWh).
17. Voltage.
18. Overload indication, shows a warning at 90%. The product stops at 100%.
19. Motor current.

6.11 CAN bus system

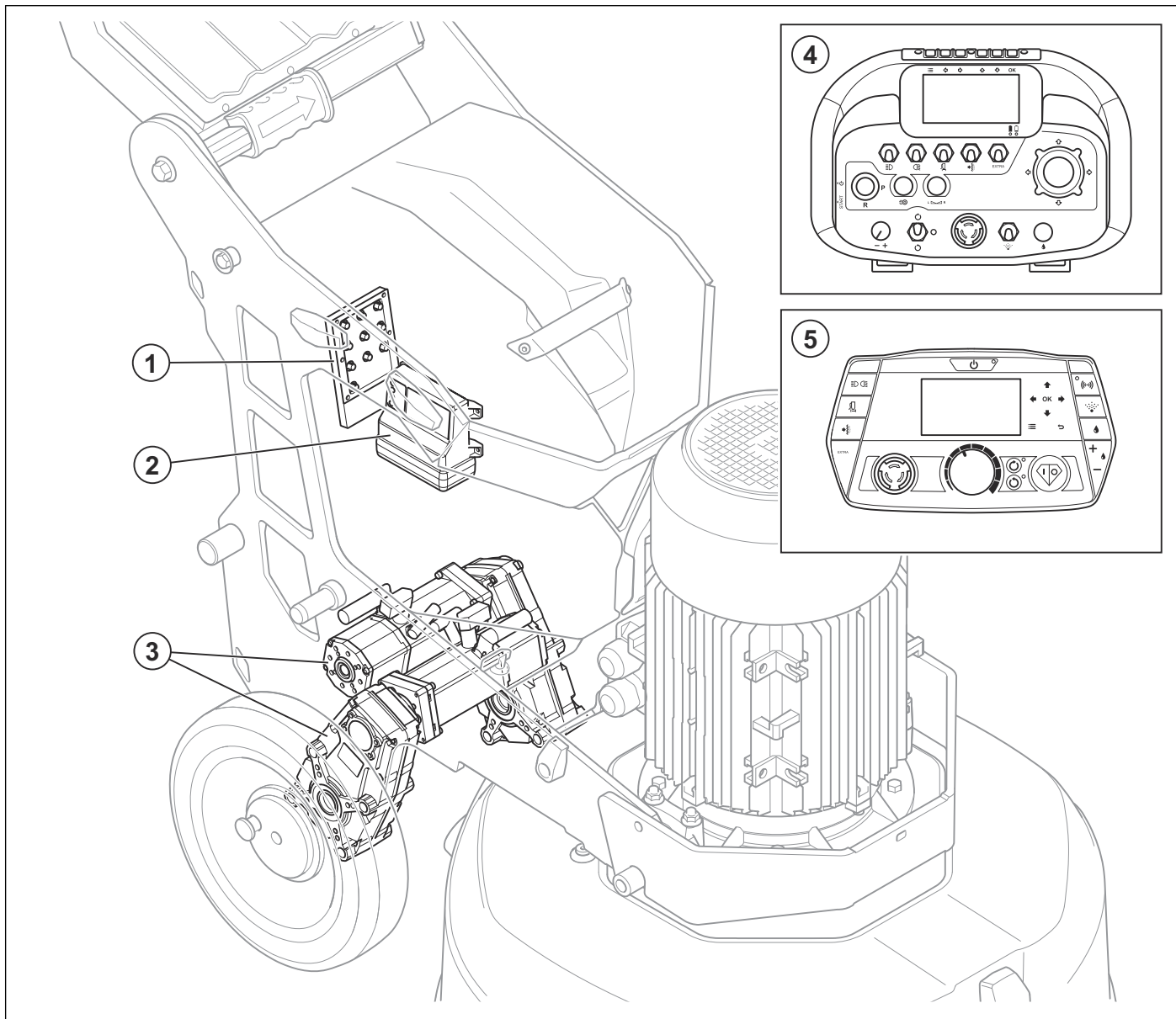

1. Connection panel
2. Remote control unit receiver
3. Powertrain
4. Remote control
5. Control panel on the product

7 Repair and servicing

7.1 Motor

7.1.1 To remove the motor and the grinding head

1. Remove the weights from the frame.

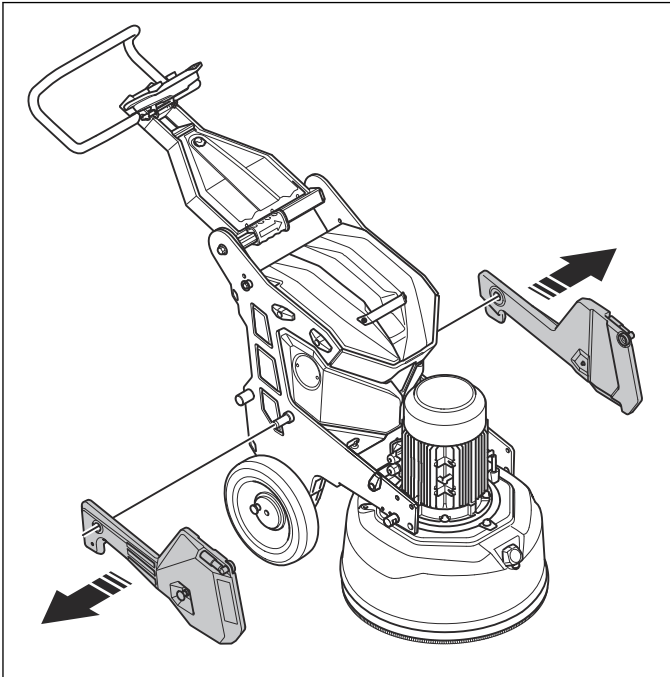

2. Remove the screws and the top brackets.

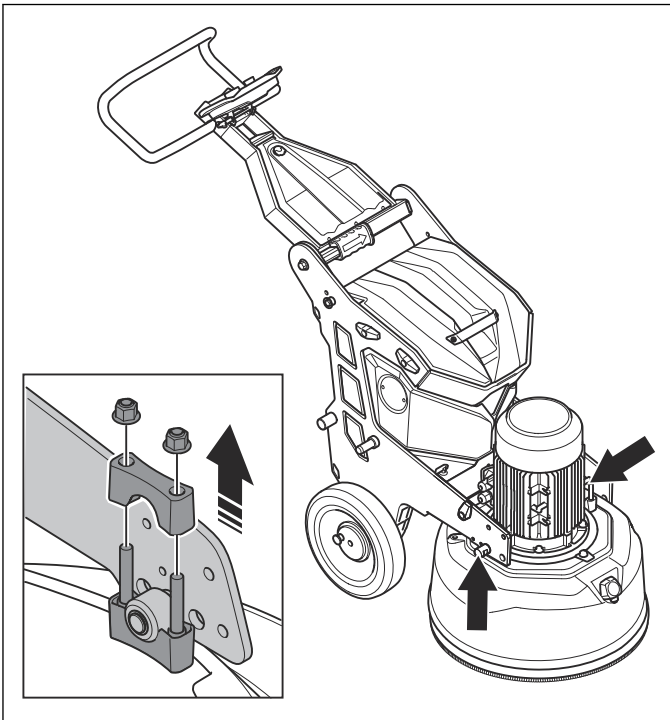

3. Pull the frame away from the motor and grinding head.

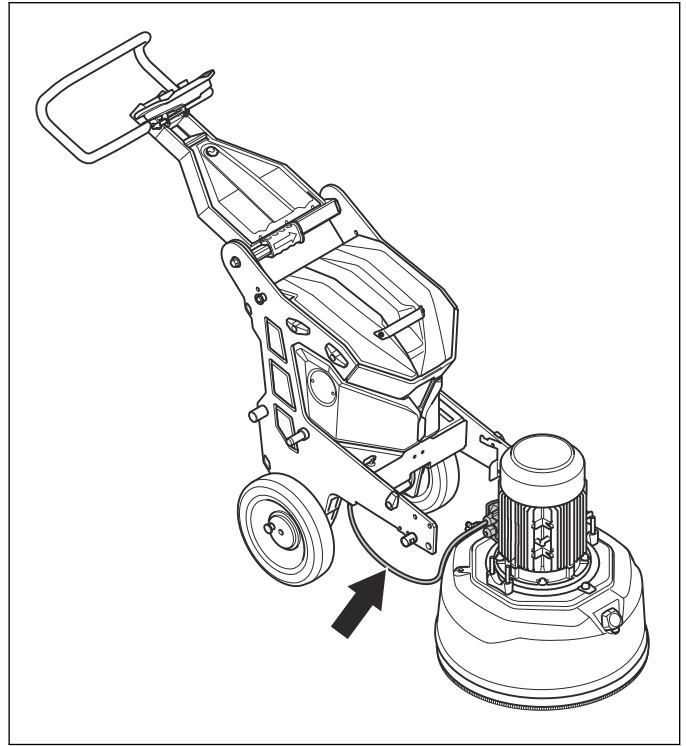

CAUTION: Do not pull the cable.

4. Open the motor connection box.

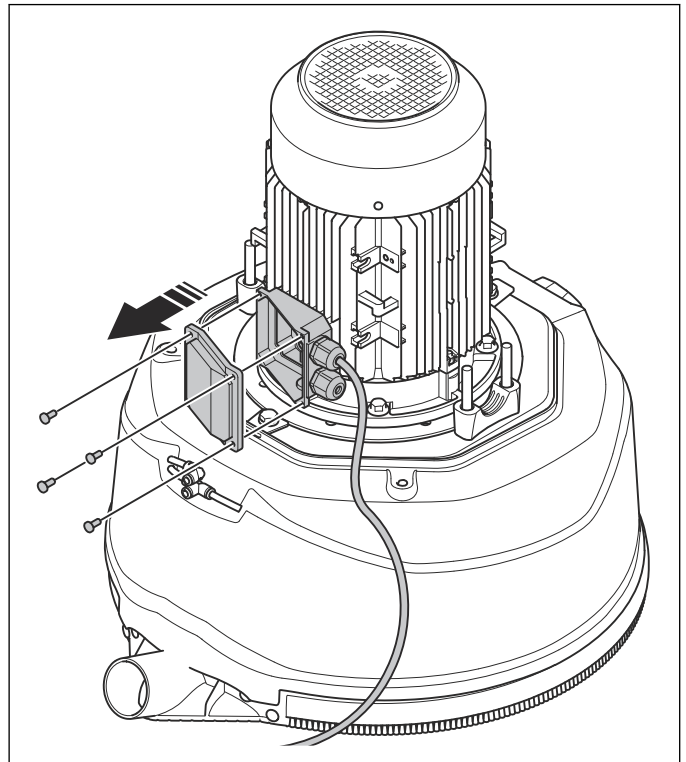

5. Remove the cable from the motor connection box.

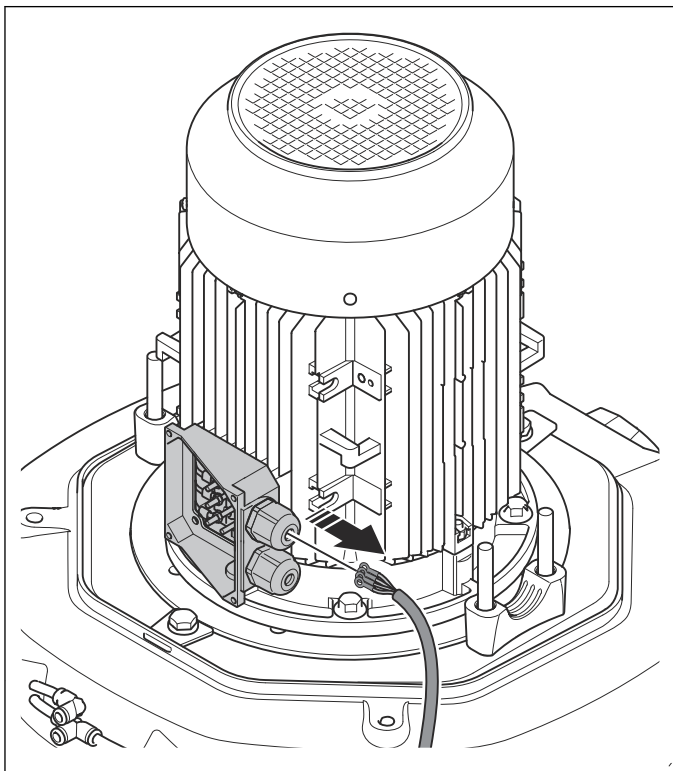

6. Remove the frame from the motor and grinding head.

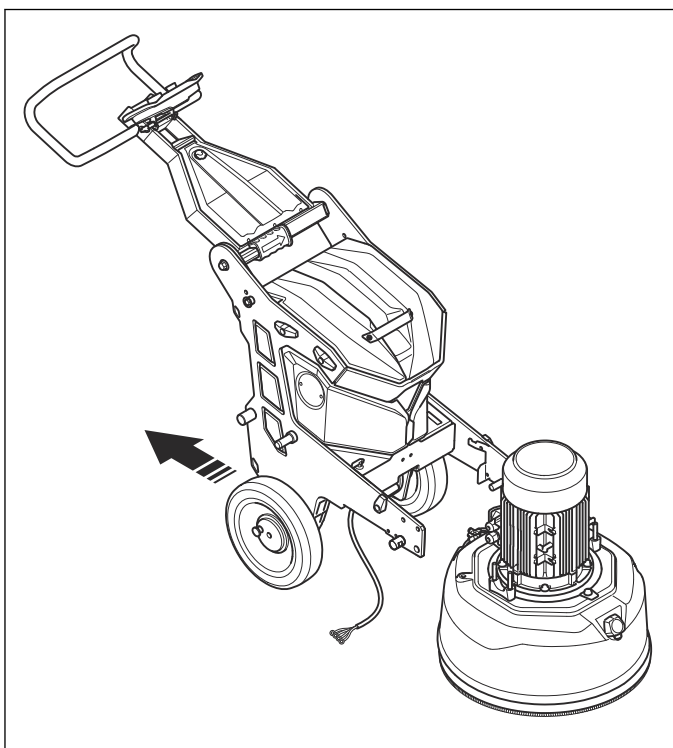

7.1.2 To remove the motor from the grinding head

1. Remove the screws.

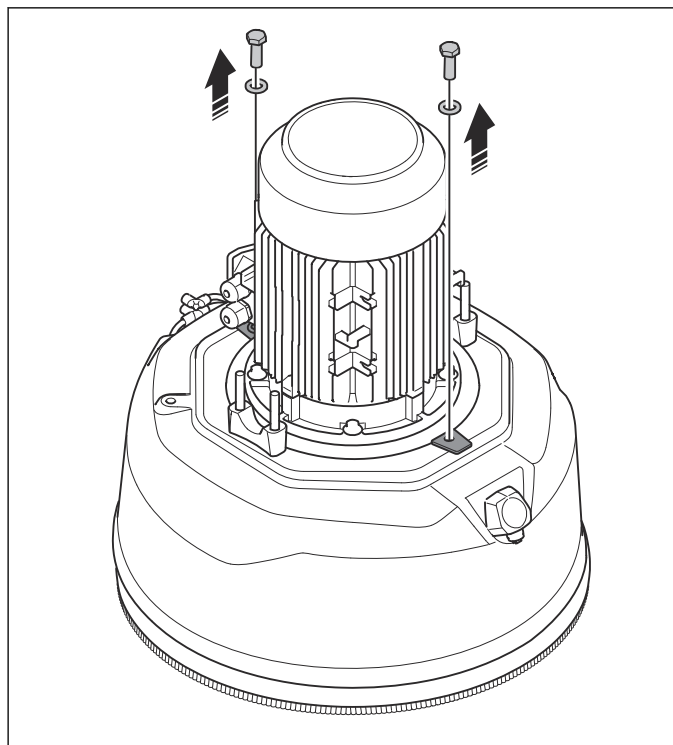

2. Remove the washers.

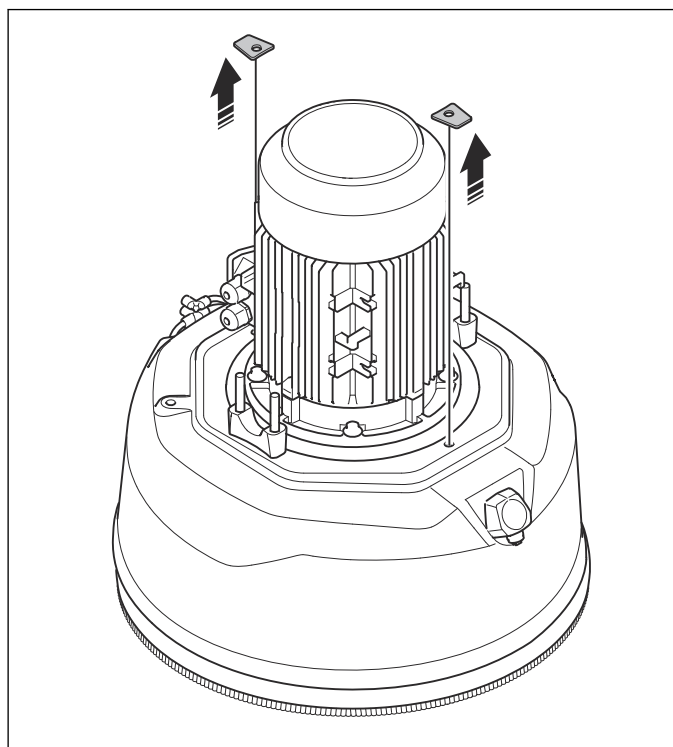

3. Remove the grinding head cover.

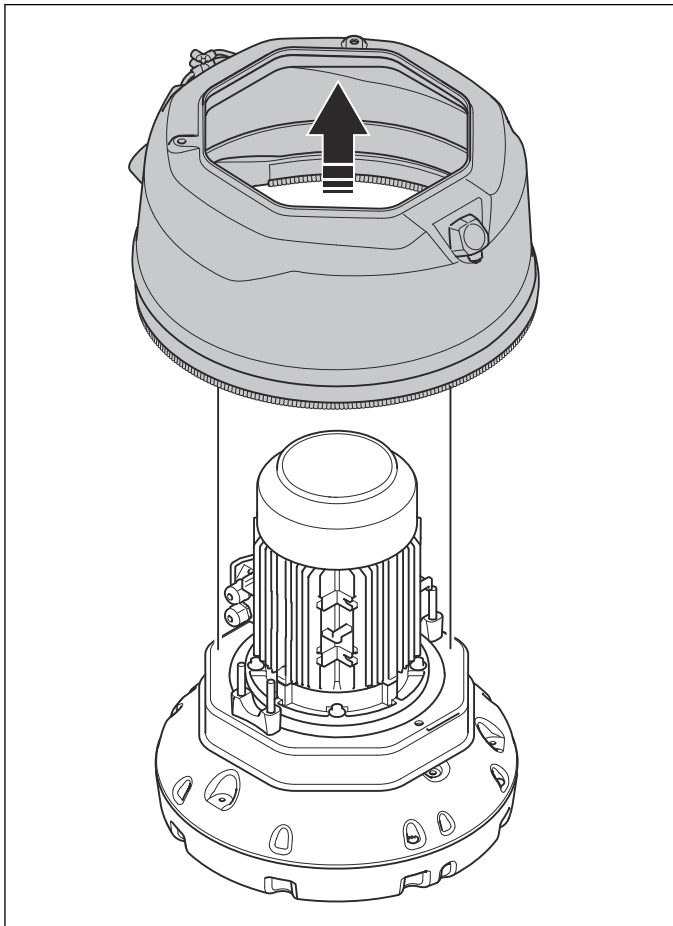

5. Remove the screws that hold the motor.

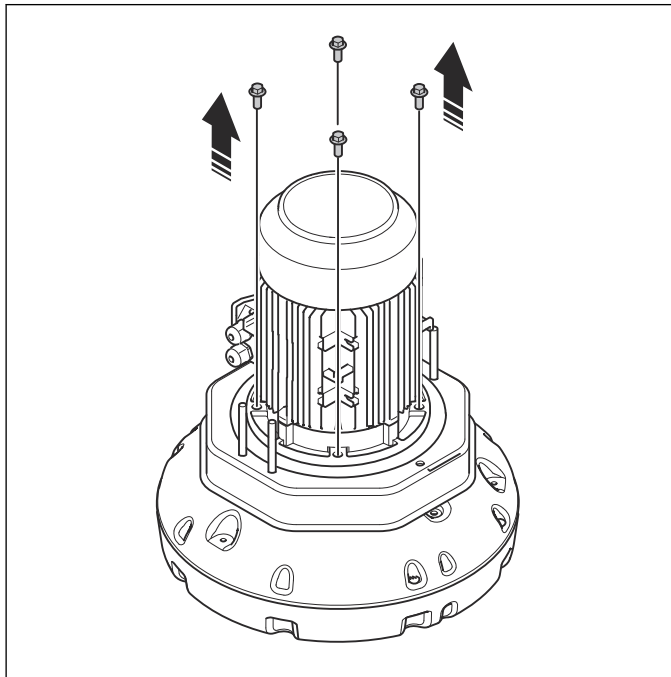

4. Remove the bottom brackets for the frame.

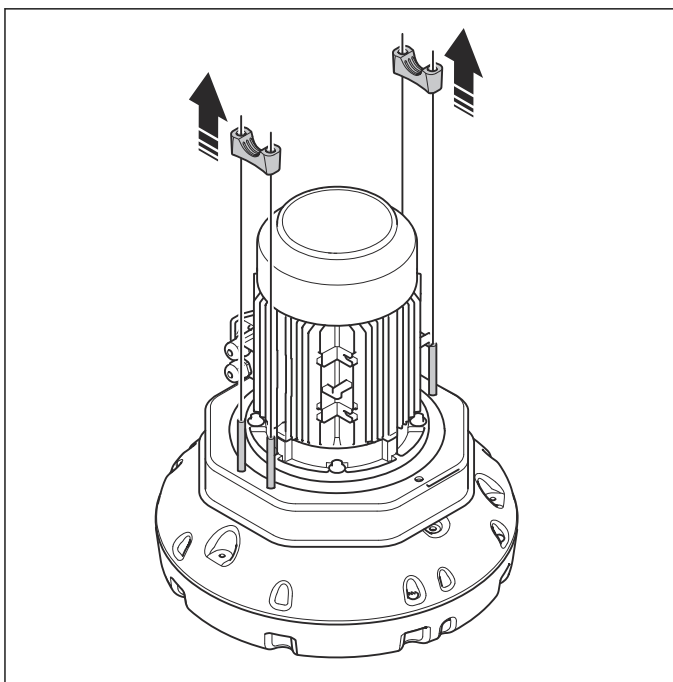

6. Remove the motor.

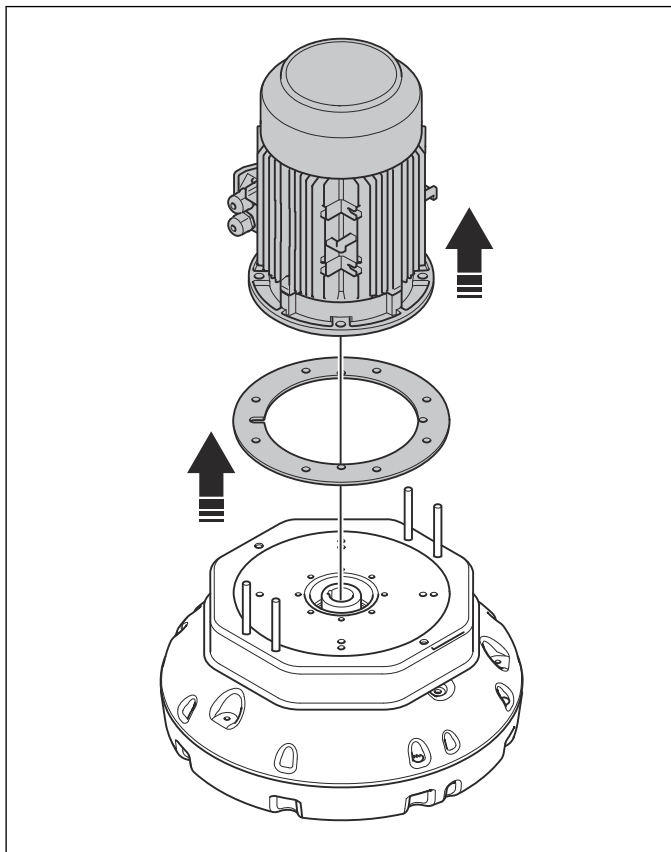

7. Remove the motor plate and the grinding head cover guide.

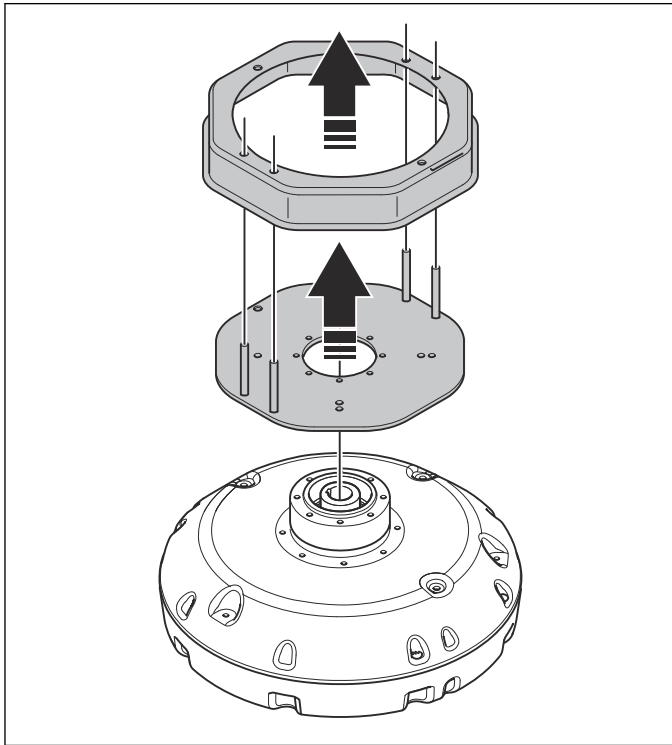

8. If the motor cannot be removed, use the removal tool.

- 15 kW motors: 595 76 16-01
- 7.5 kW motors: 595 76 15-01

9. Remove the lid from the housing. Refer to *To open the grinding head on page 30*.

10. Put support below the grinding head. Make sure there is space for the removal tool.

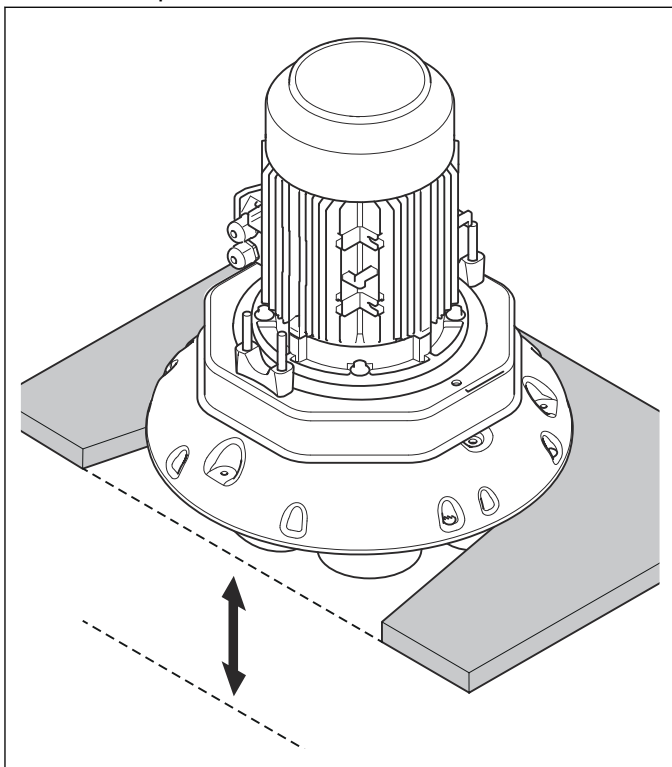

11. Put the removal tool into the center pulley.

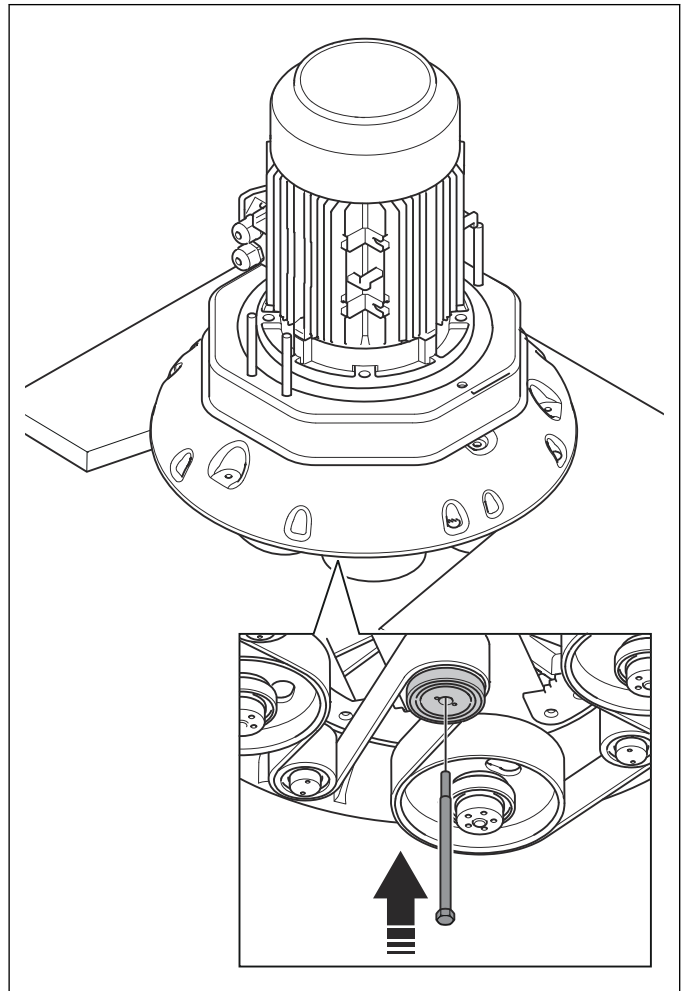

12. Turn the removal tool to remove the motor.

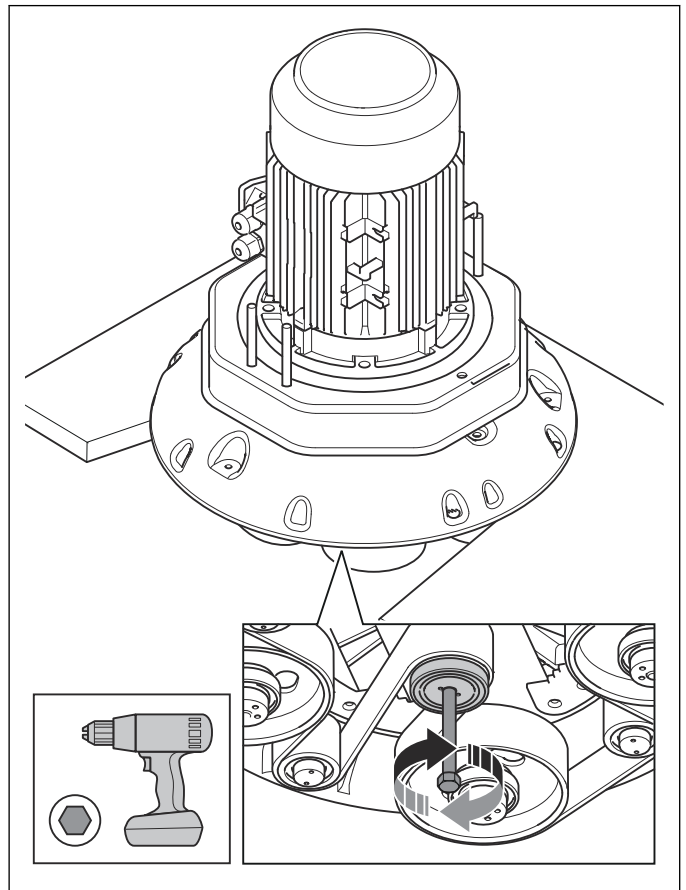

7.2 Tool holders

7.2.1 To remove the tool holders

1. Remove the screws.

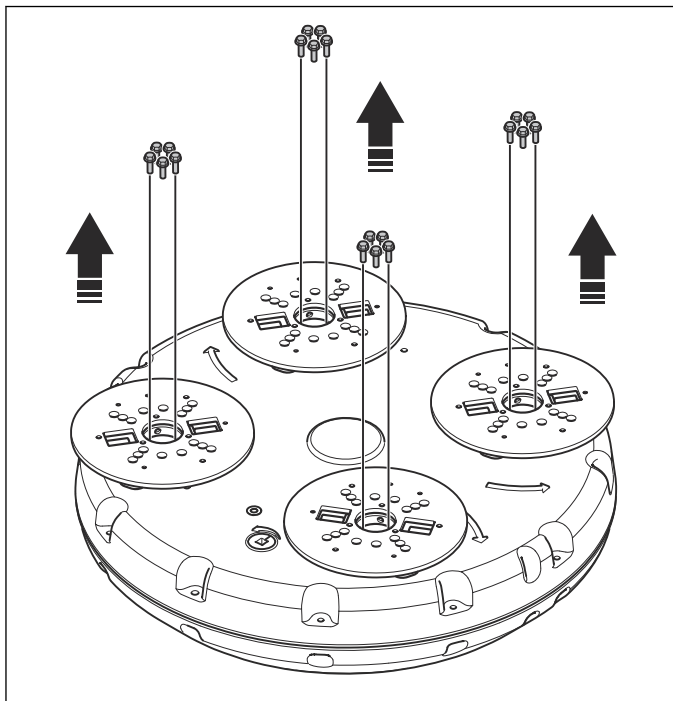

2. Remove the tool holders.

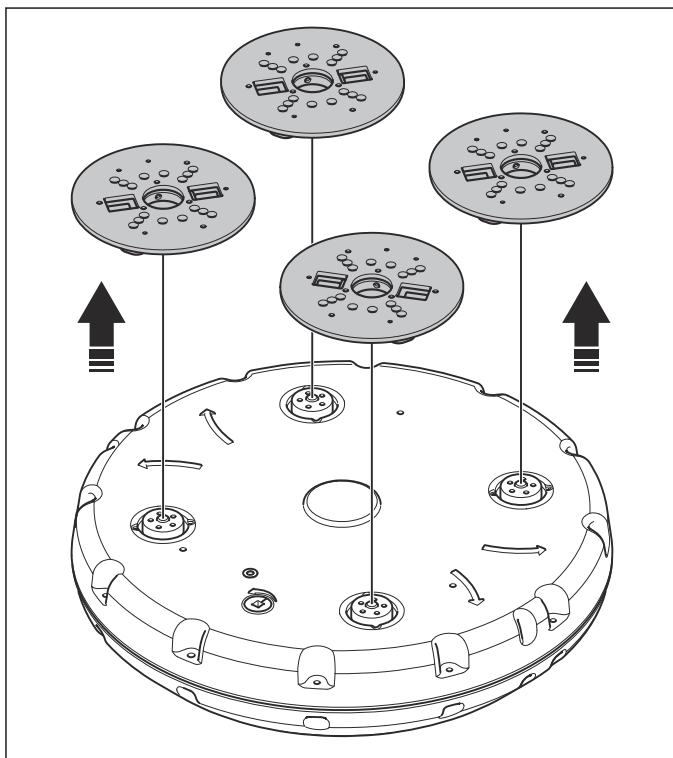

7.3 Grinding head

7.3.1 To open the grinding head

1. Loosen the belt tensioner screw.

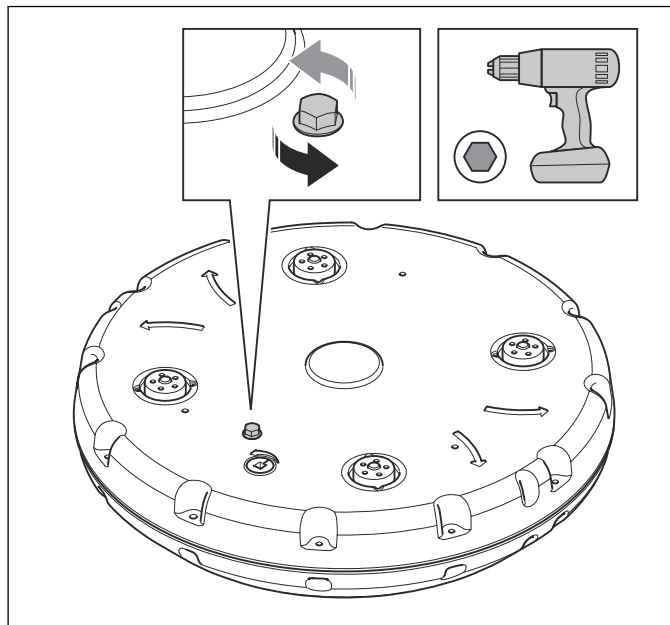

2. Make sure that the line on the belt tensioner aligns with mark on the arrow.

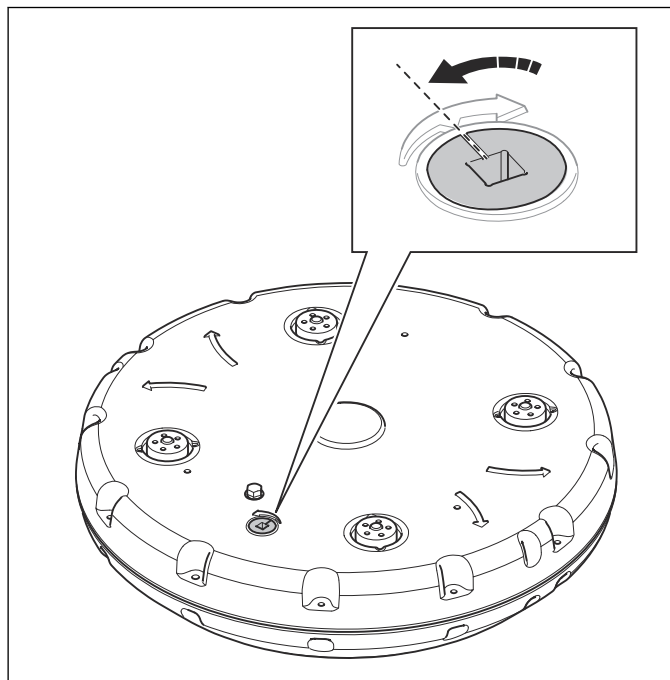

3. Remove the 12 screws from the lid.

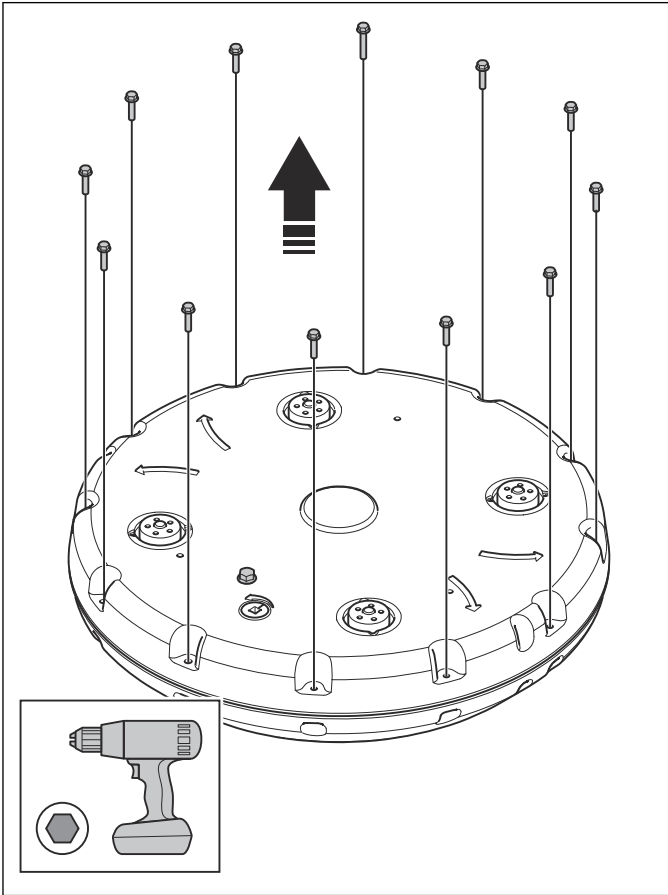

4. Put removal tools for the grinding head in 3 of the holes.

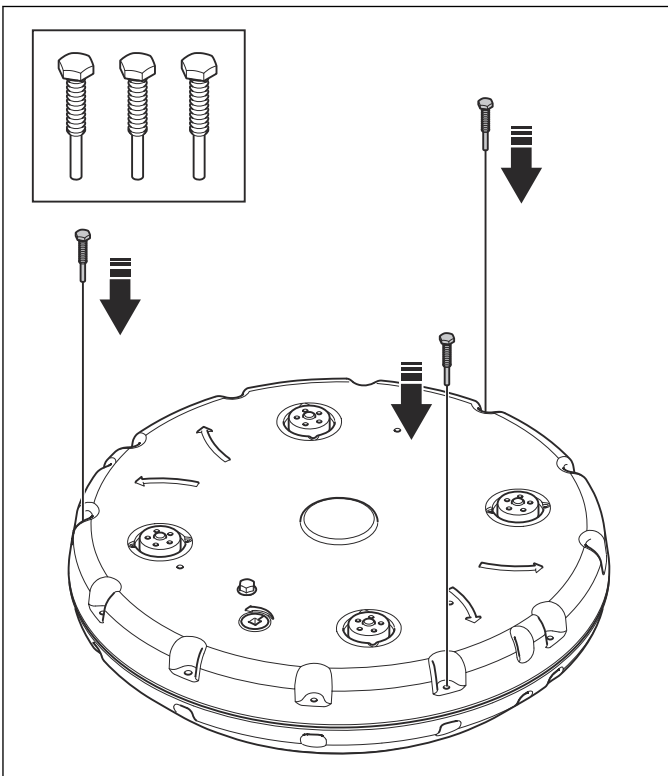

Tool number: 593 54 45-01

5. Tighten the removal tools for the grinding head. Refer to the picture and tighten in sequence from A to F.

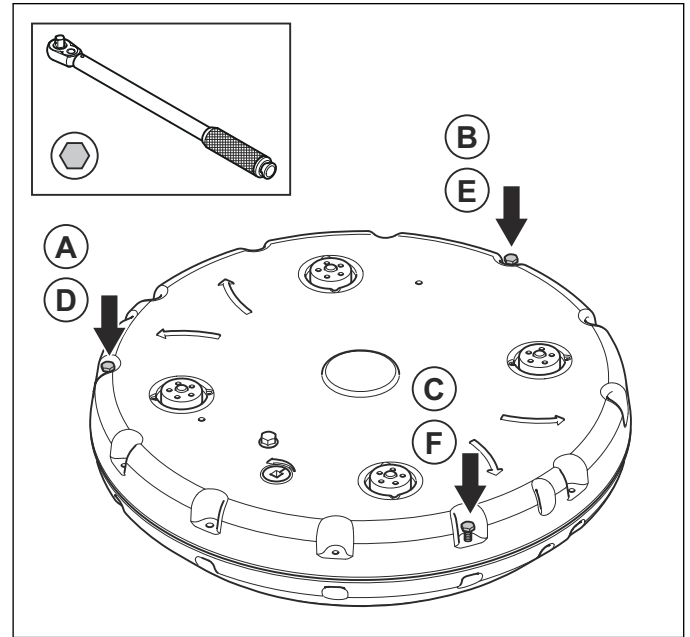

6. Remove the lid from the housing.

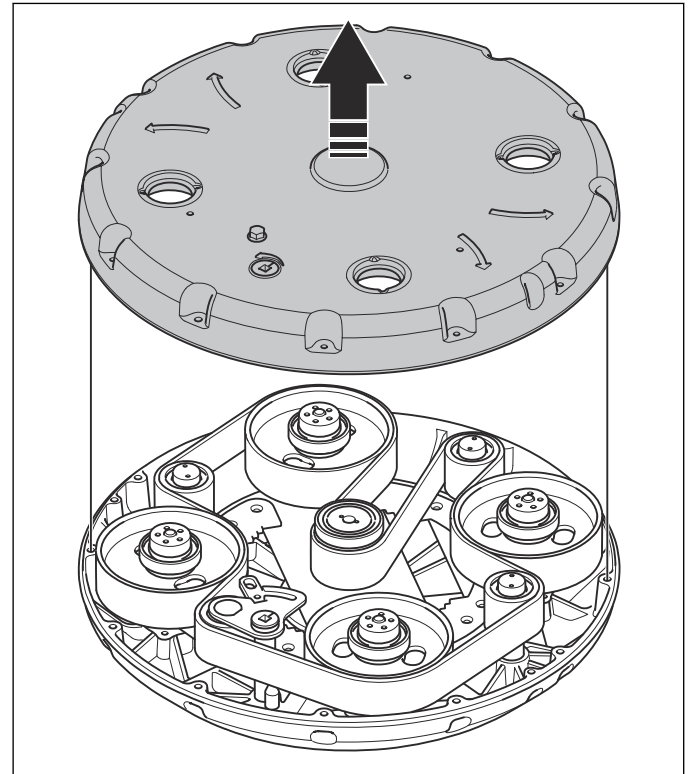

7. Remove the O-ring from the housing.

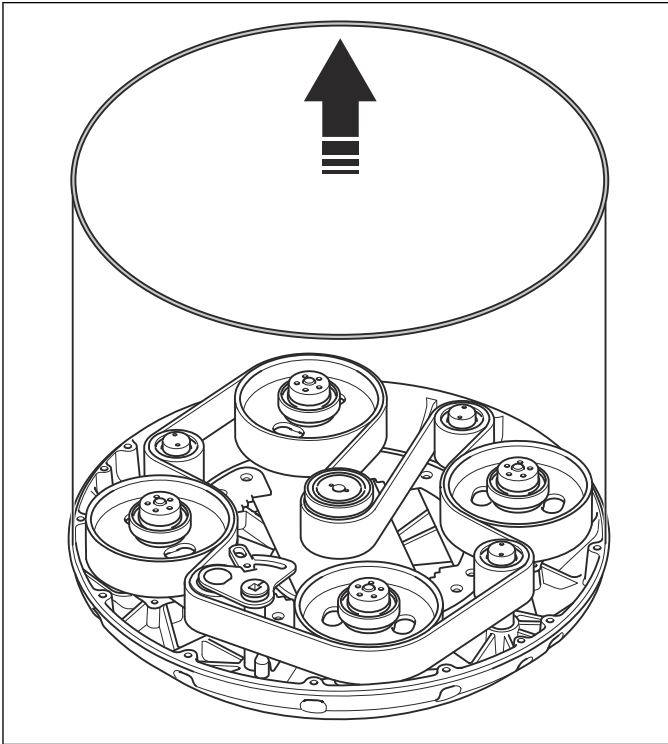

8. Discard the O-ring.

7.3.2 To close the grinding head

1. Install the new O-ring on the housing.

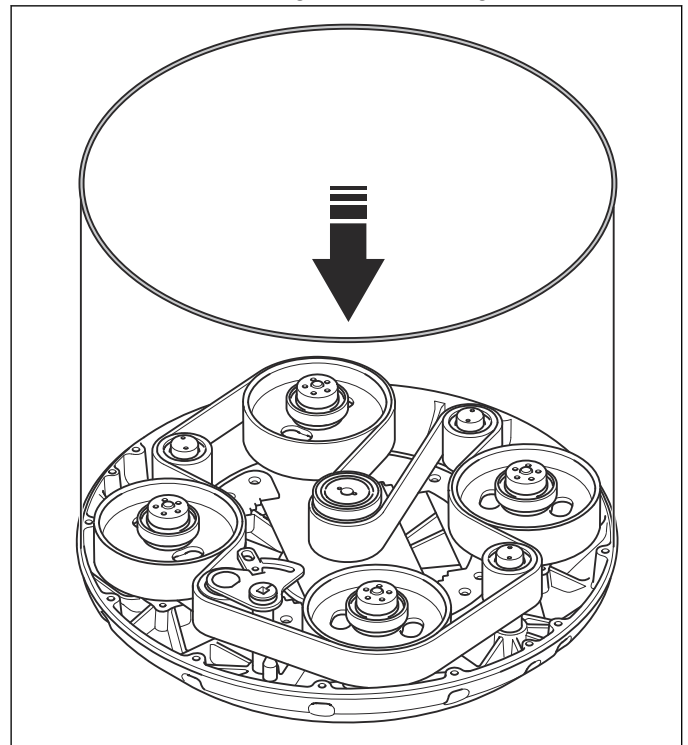

2. Make sure that the line on the belt tensioner aligns with the mark on the arrow.

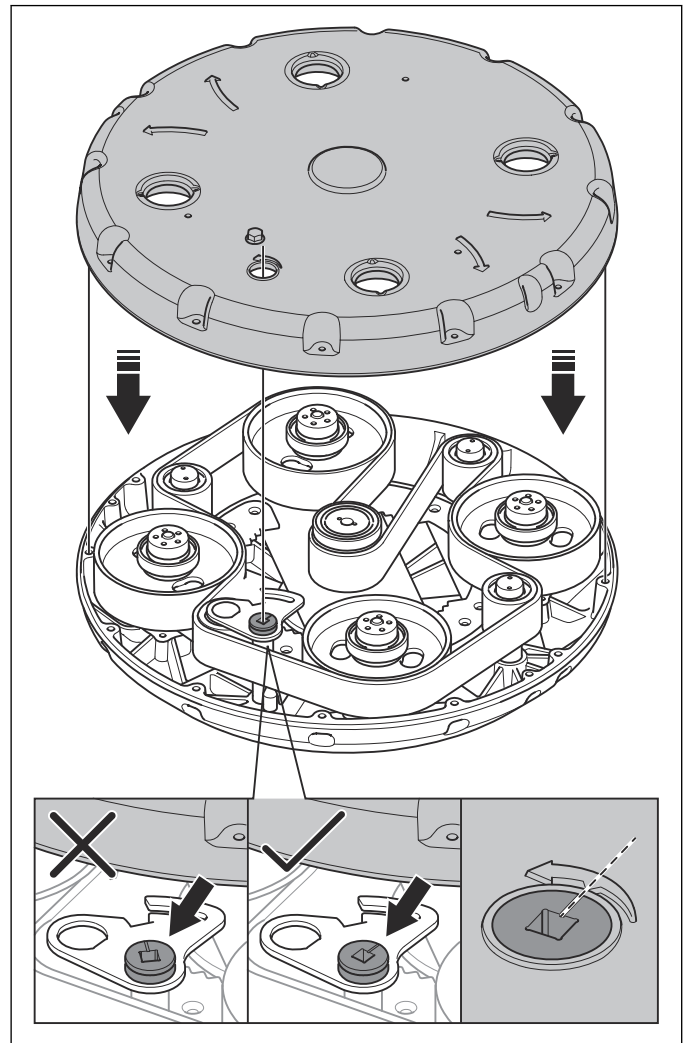

3. Put the lid on the housing.

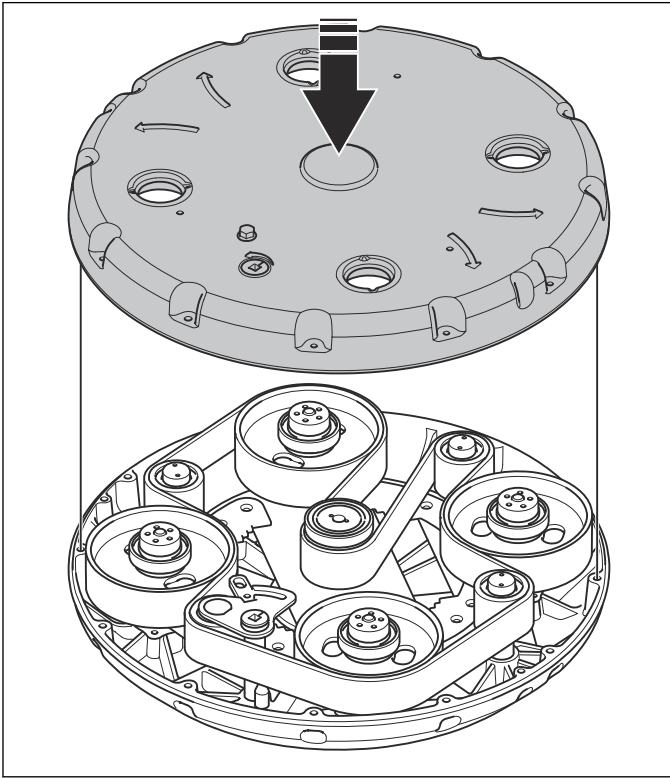

4. Put the 12 screws in the 12 holes.

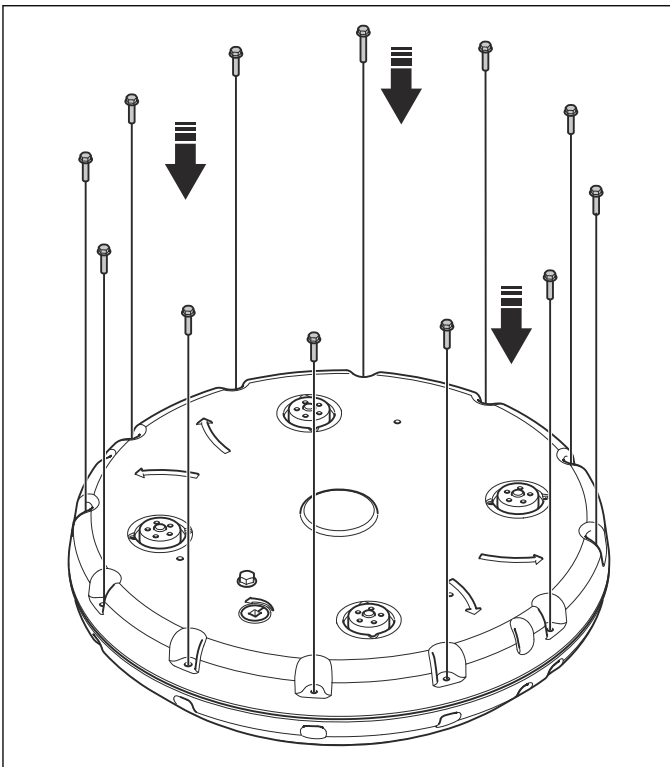

5. Tighten the screws. Use a torque wrench. Refer to the picture and tighten in sequence from A to F.

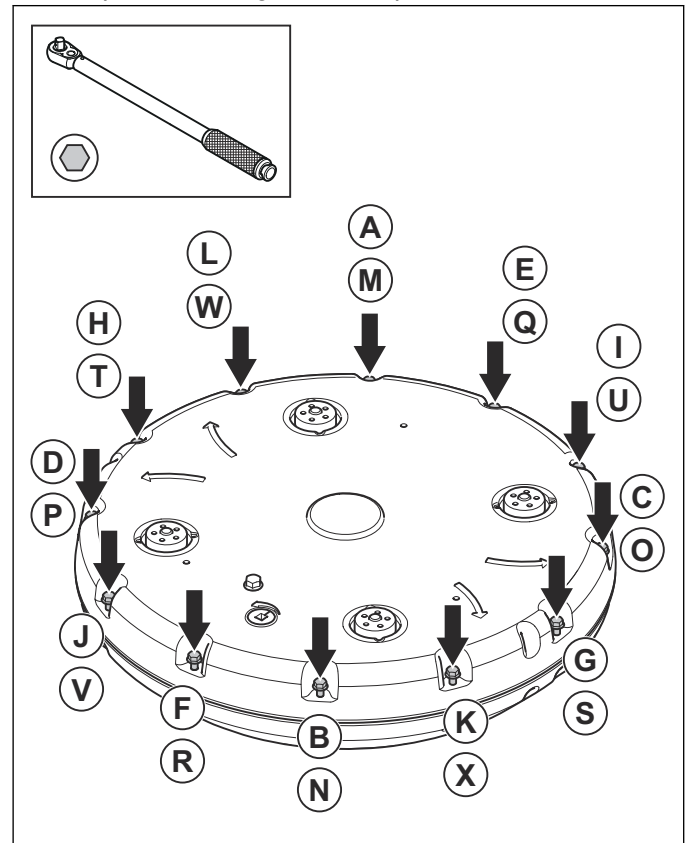

6. Use a torque wrench to adjust the belt tensioner. Hold the correct tension (B) and tighten the locknut (A).

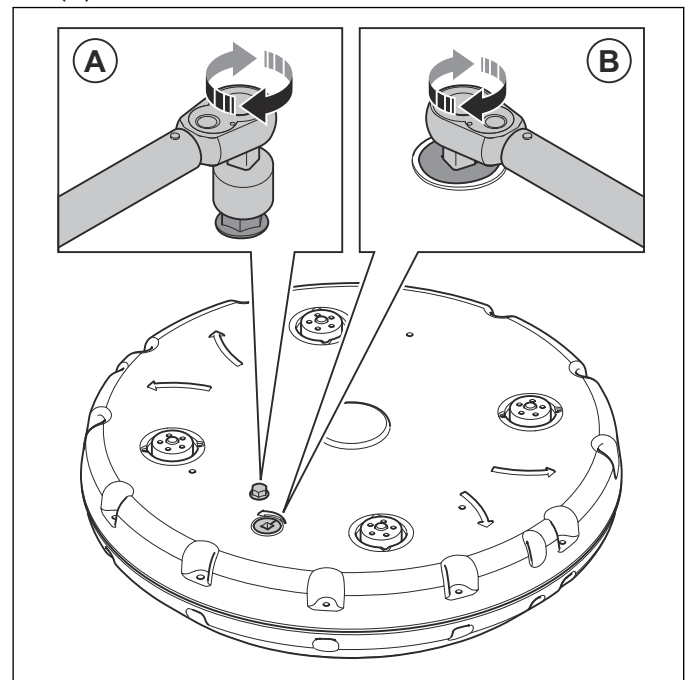

The correct tightening torque for the lock nut is 70 Nm. The correct tension for the belt tensioner is:

- T6: 200 Nm
- X6: 230 Nm
- T8: 210 Nm
- X8: 210 Nm

7.4 Radial shaft seal

7.4.1 To remove the radial shaft seals

1. Remove the radial shaft seals. Use a screwdriver.

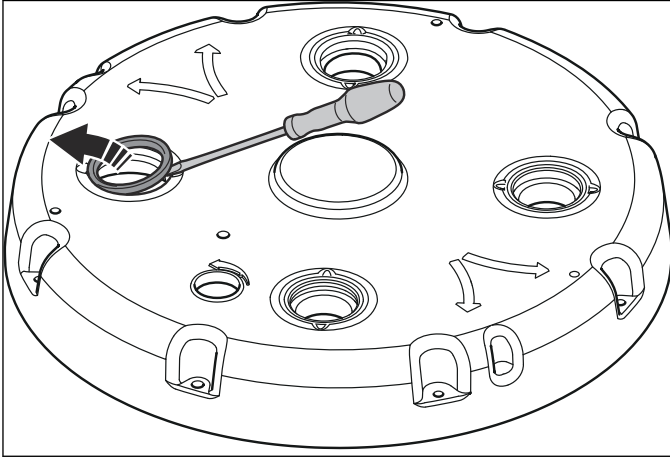

2. Discard the radial shaft seals.

7.4.2 To install the radial shaft seals

1. Put 4 radial shaft seals on top of the holes in the lid.

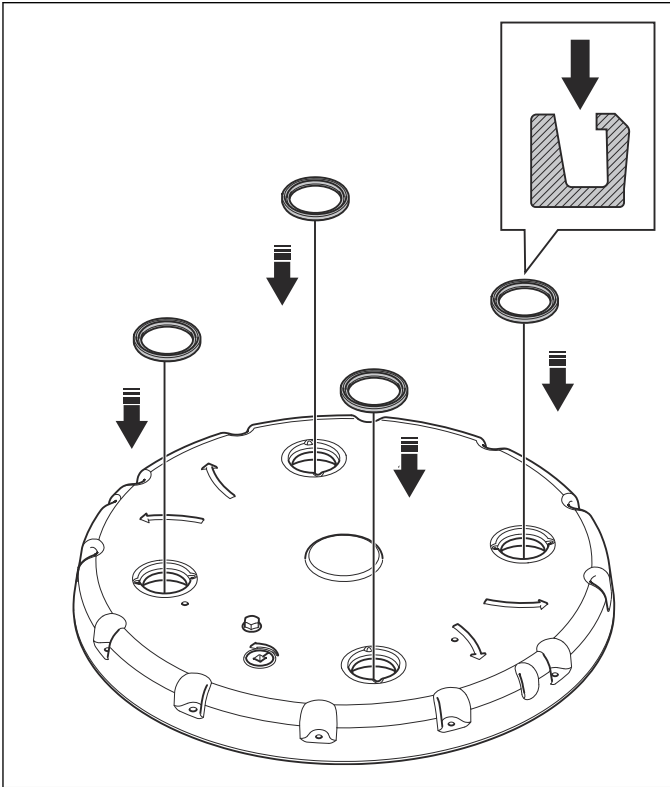

Note: Make sure that the flat side of the radial shaft seal points down in the lid. Refer to the picture.

2. Push the radial shaft seals into the holes. Use a press and a press tool for the radial seals.

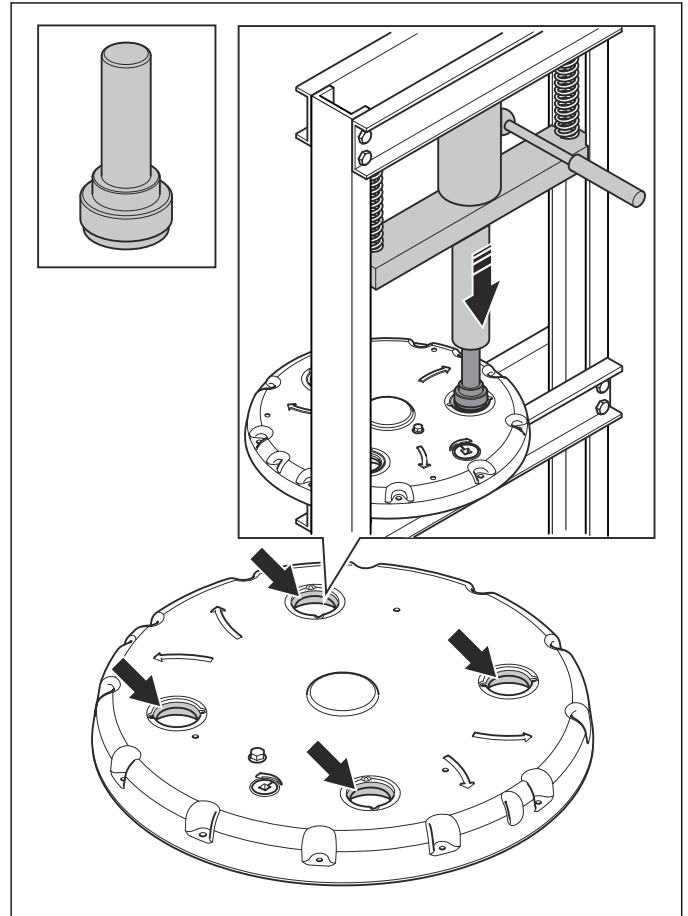

Tool number: 593 54 21-01

3. Apply grease.

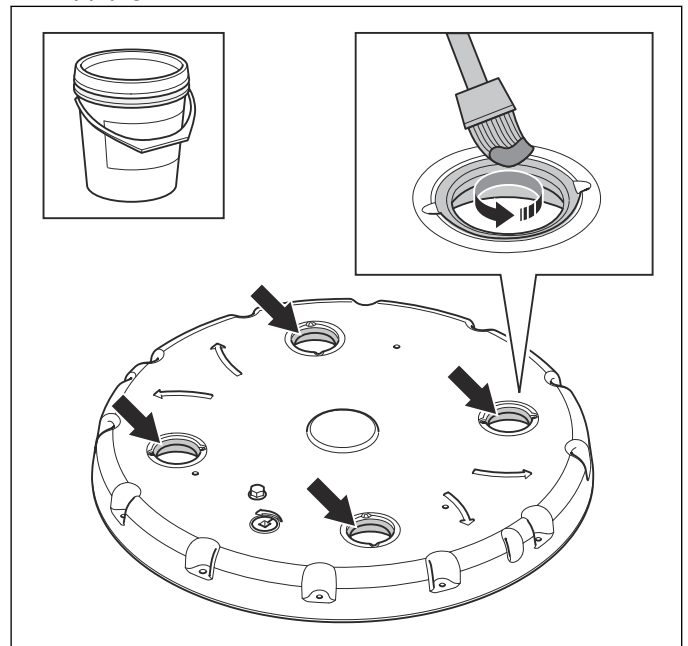

Use Molykote W2 Multipurpose grease.

7.5 Belt tensioner

7.5.1 To remove the belt tensioner

1. Remove the belt tensioner from the housing.

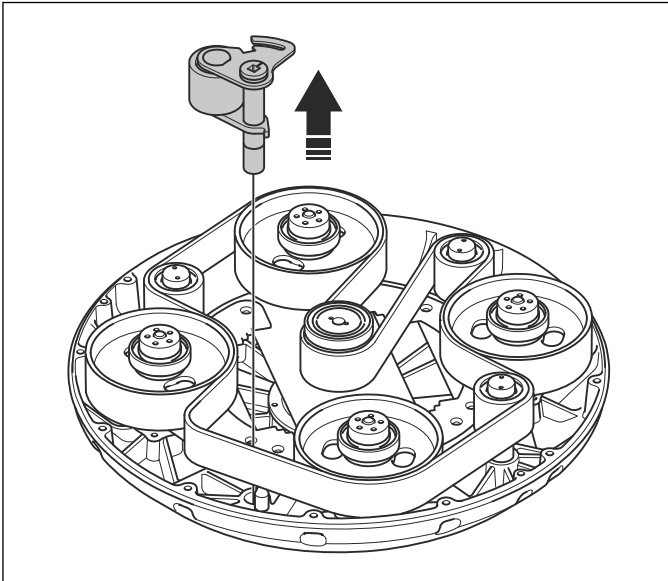

2. Remove the belt tensioner stop.

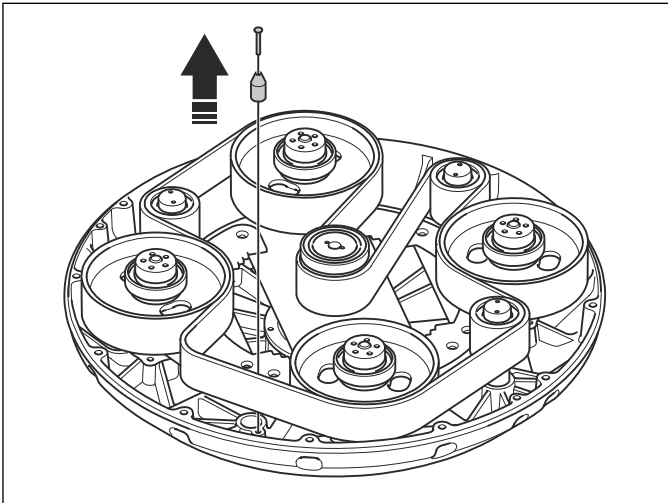

7.5.2 To disassemble the belt tensioner

1. Remove the O-ring from the belt tensioner.

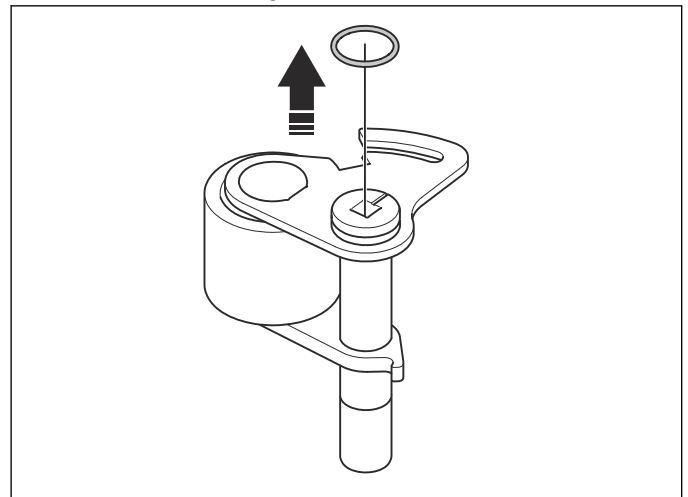

2. Remove the idler shaft.

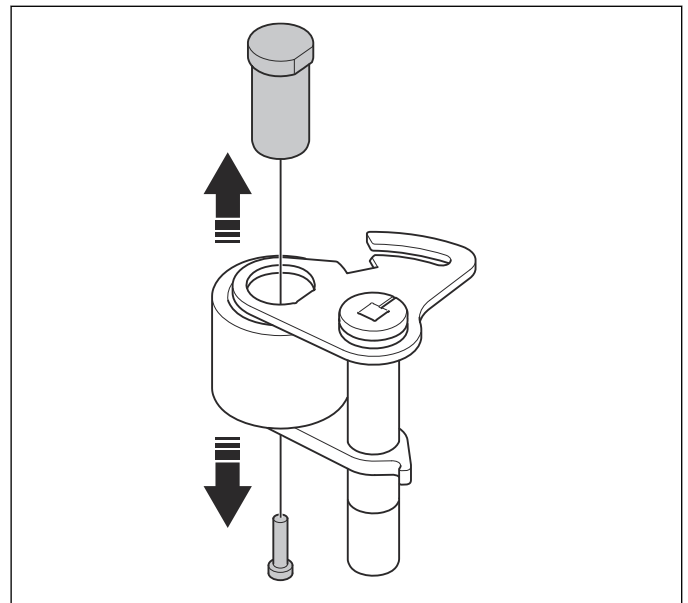

3. Remove the washer.

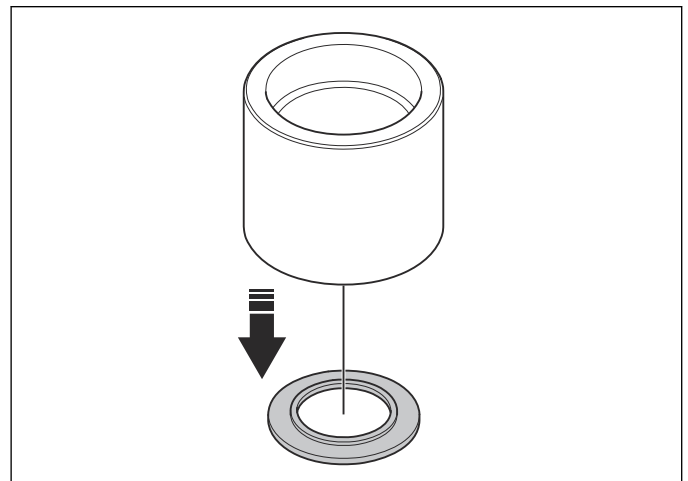

- Remove the bearings from the idler pulley. Use a mandrel.

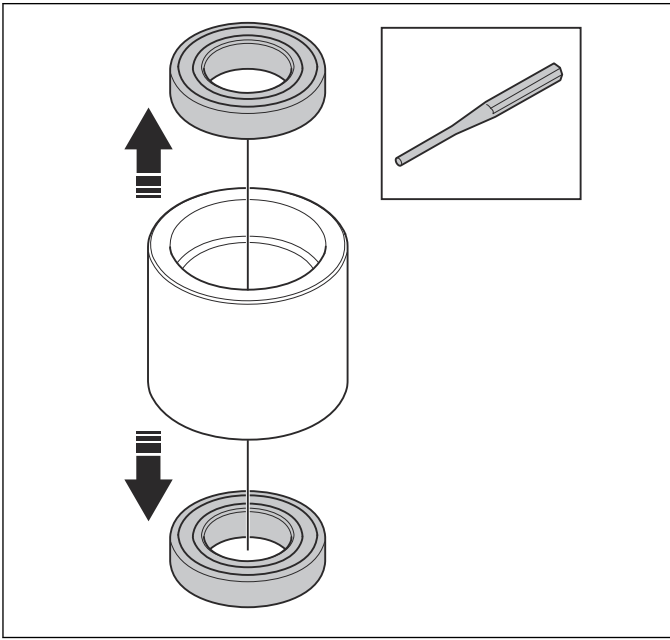

7.5.3 To assemble the belt tensioner

- Push the bearings into the idler pulley. Use a force of 2000 kg. Use a press tool (A).

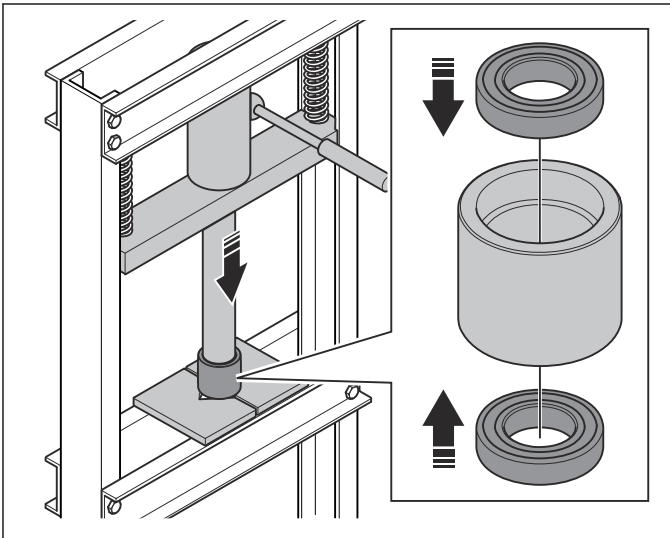

Tool number: 593 54 19-01.

- Put the washer into the idler pulley.

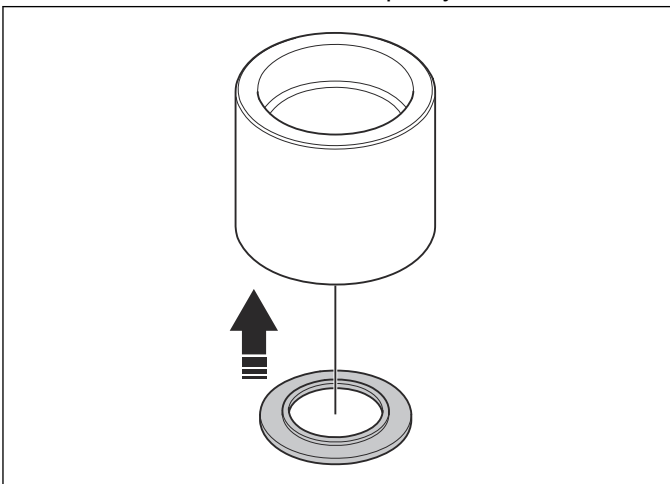

- Put the idler pulley into the belt tensioner.

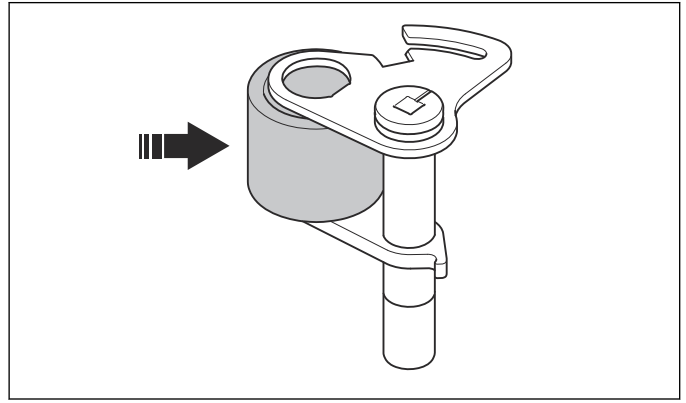

- Put the idler shaft into the belt tensioner.

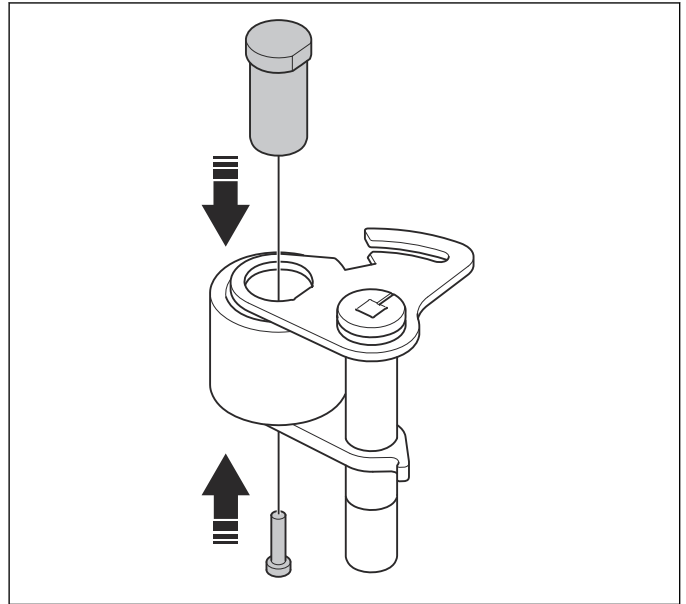

- Put the O-ring onto the belt tensioner.

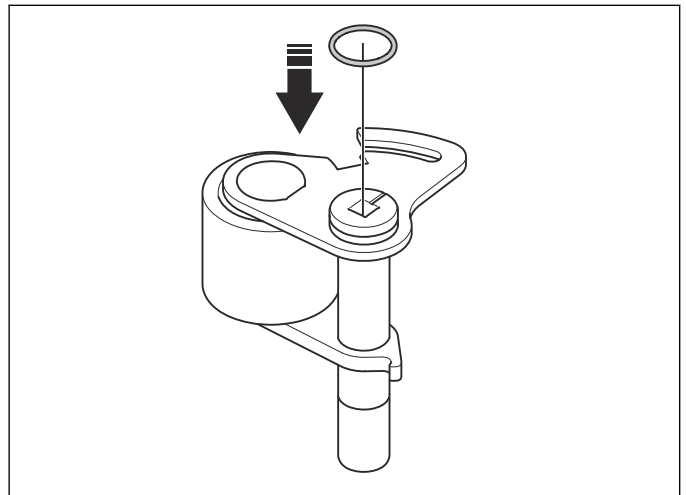

7.5.4 To install the belt tensioner

1. Install the belt tensioner in the housing.

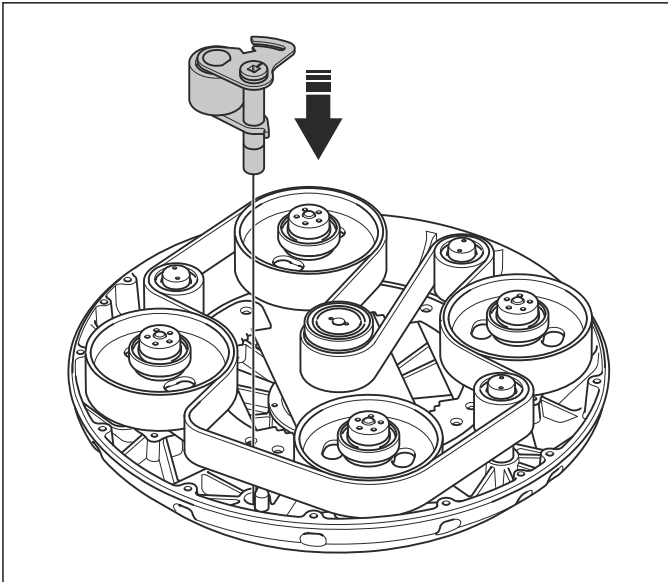

2. Install the belt tensioner stop.

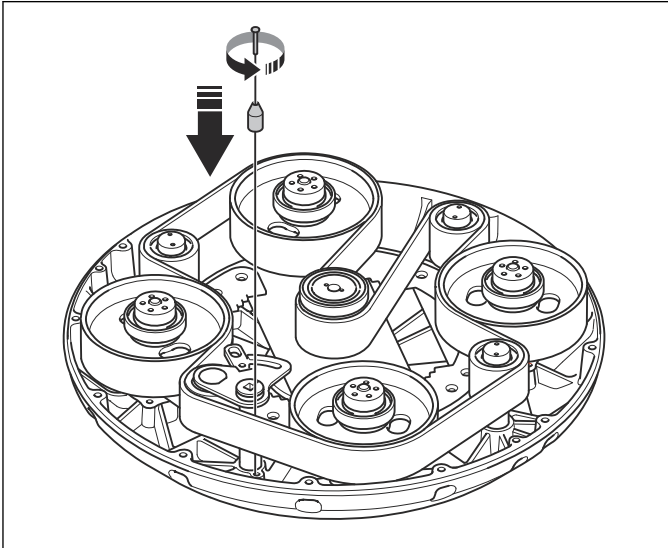

3. Apply grease around the O-ring.

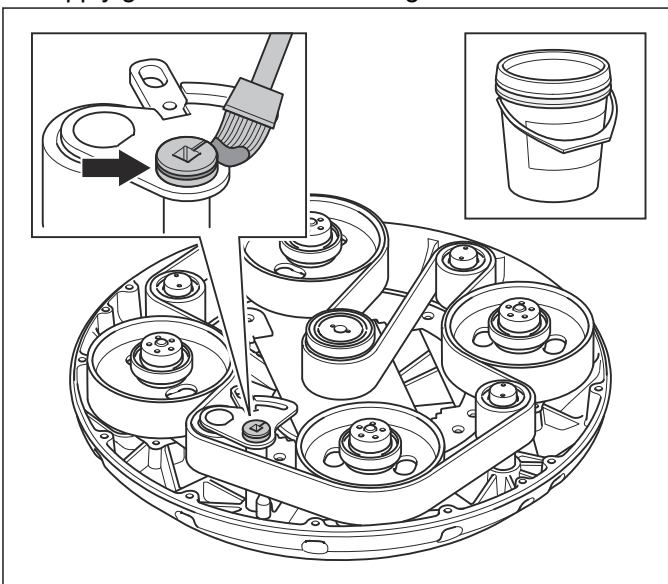

Grease: Molykote W2 Multipurpose grease.

7.6 Primary belt

7.6.1 To remove and install the primary belt

1. Remove the primary belt from the housing.

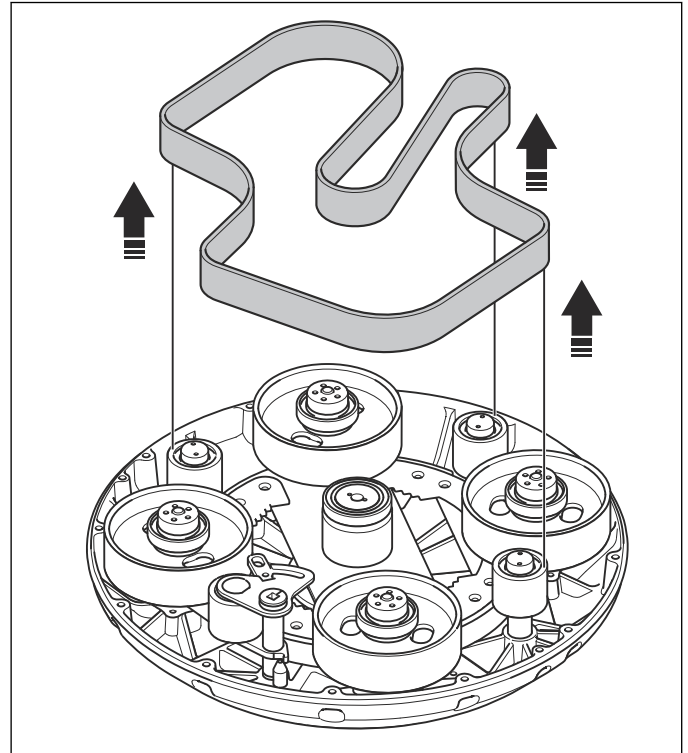

2. Install in opposite sequence.

Note: Make sure that the drive belt ribs align with the grooves on the pulley.

7.7 Hub assemblies

7.7.1 To remove the hub assembly

1. Remove the screws from the locking plates.

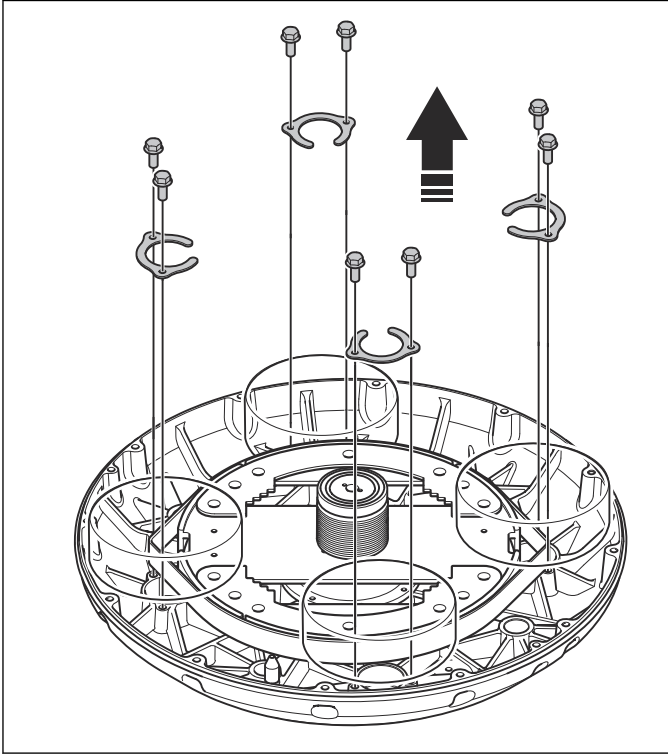

2. Turn the secondary pulley to make it possible to remove 1 hub assembly.

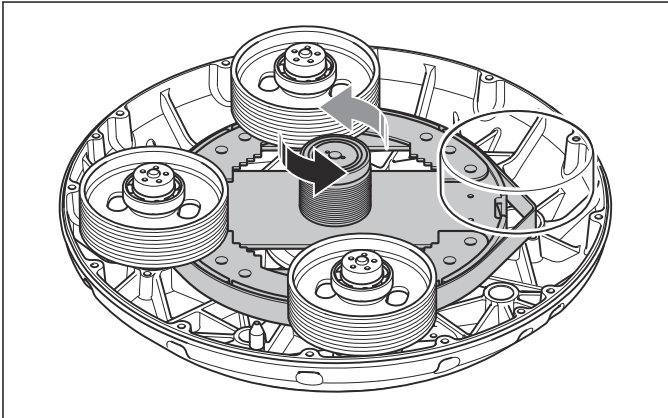

3. Remove 1 hub assembly. If the hub assembly cannot be removed by hand, put an adapter on the hub shaft.

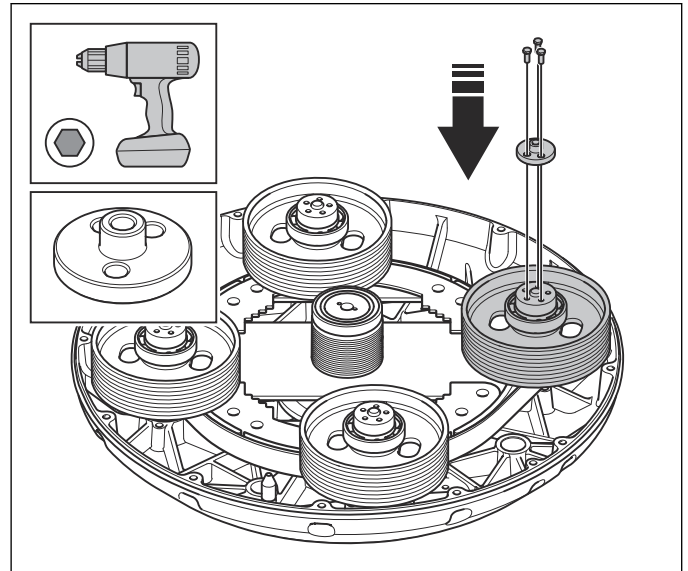

Tool number: 593 58 39-01

4. Remove the hub assembly with a sliding hammer.

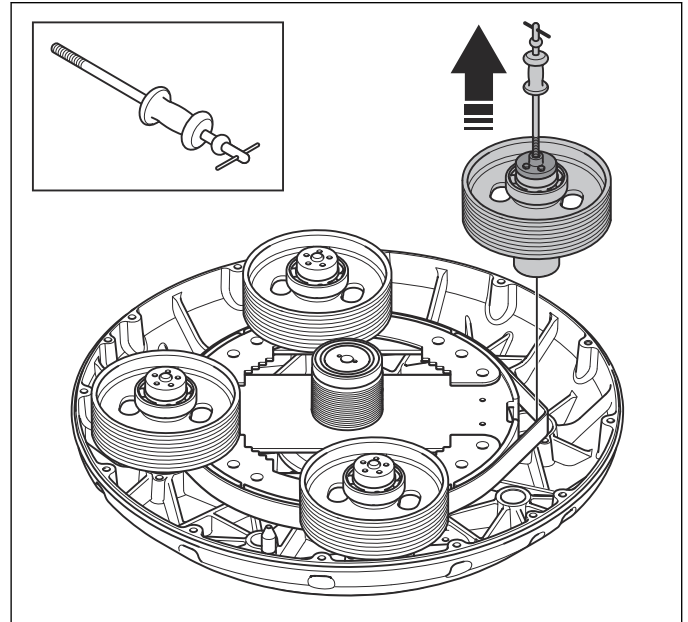

7.7.2 To install the hub assemblies

1. Turn the secondary pulley to make it possible to install the hub assemblies.

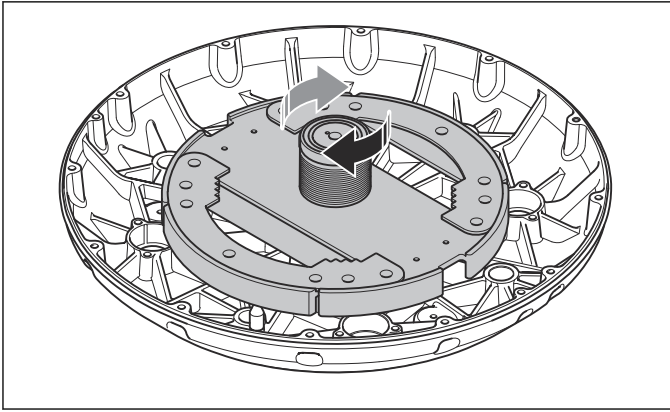

2. Install 2 hub assemblies.

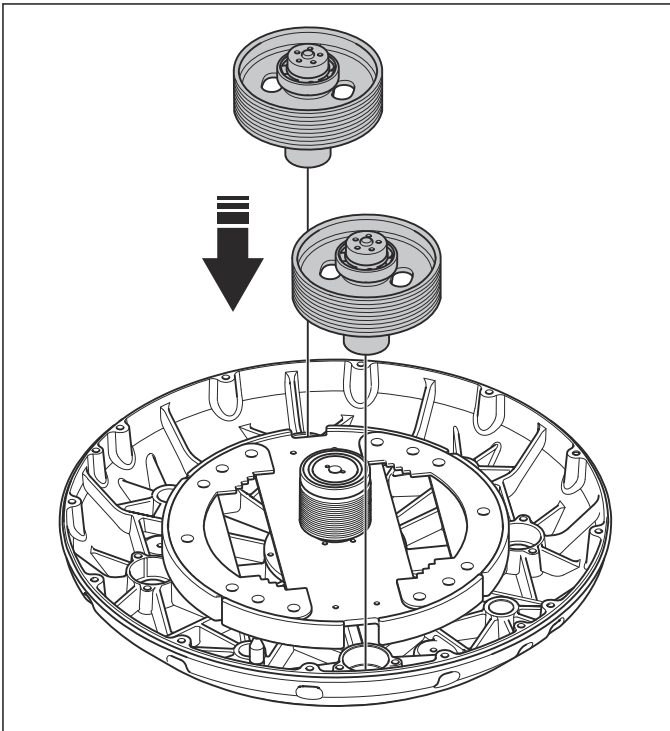

3. Push in the locking plates.

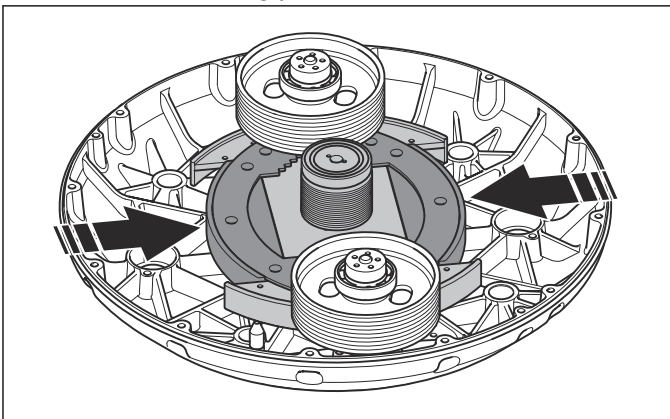

4. Turn the secondary pulley to make it possible to install the other 2 hub assemblies.

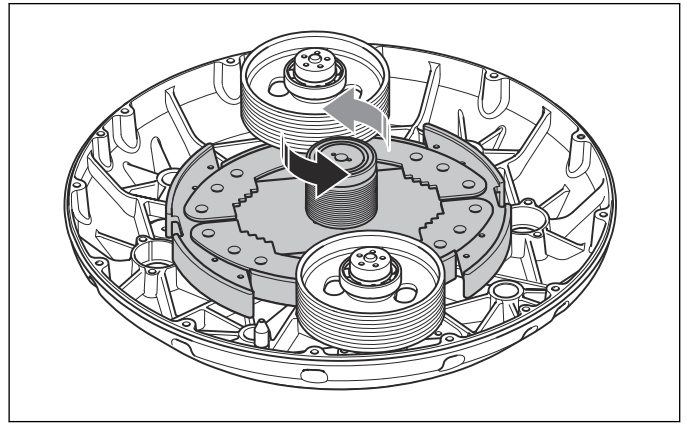

5. Install 1 hub assembly.

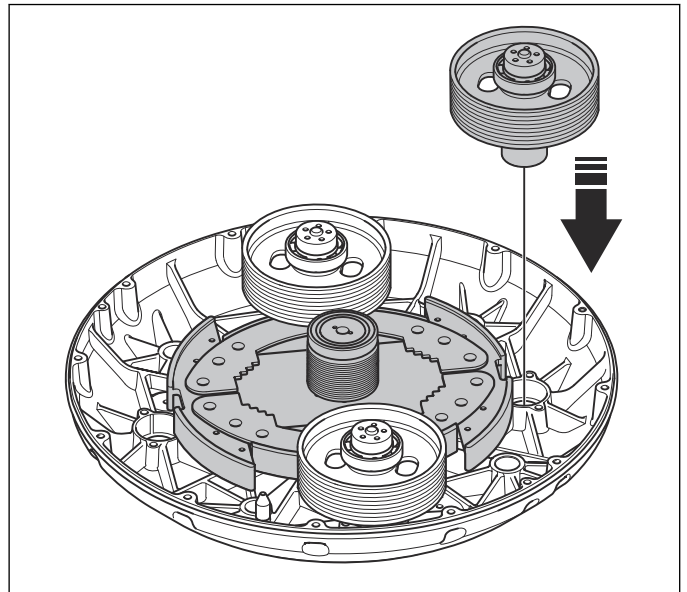

6. Install the secondary belt.

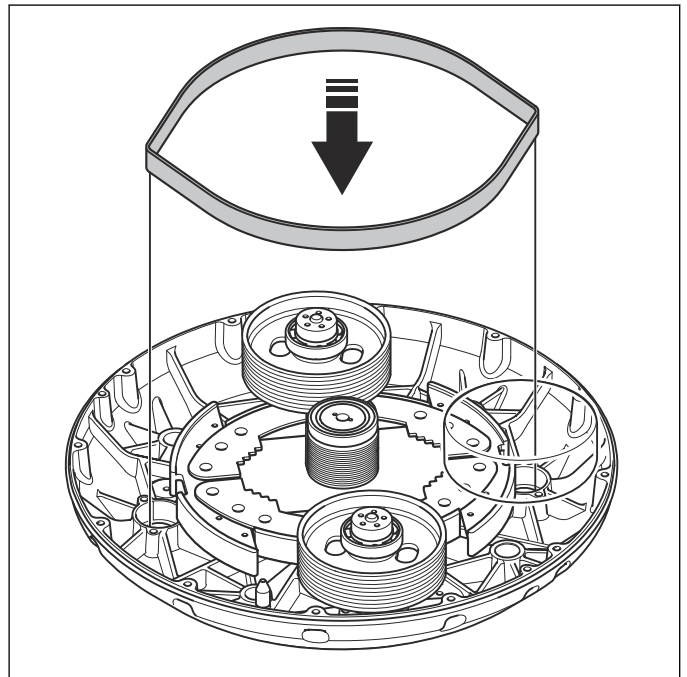

7. Install the other hub assembly.

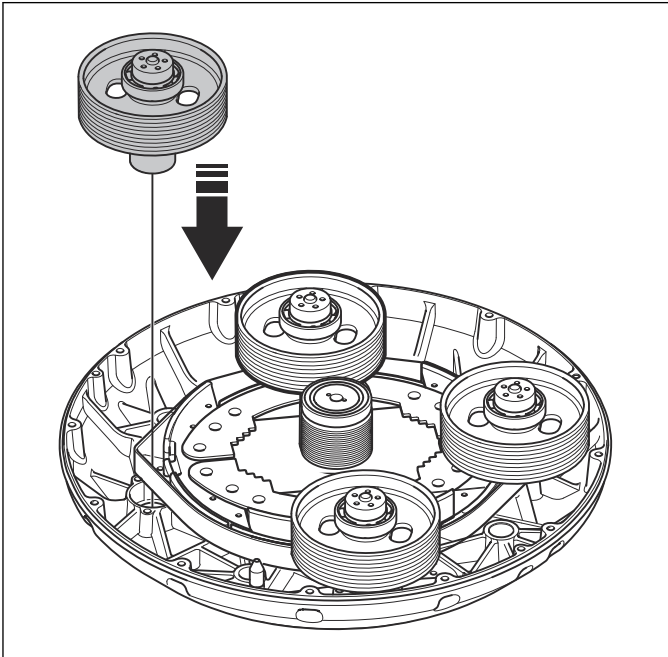

8. Pull out the locking plates and install the screws.

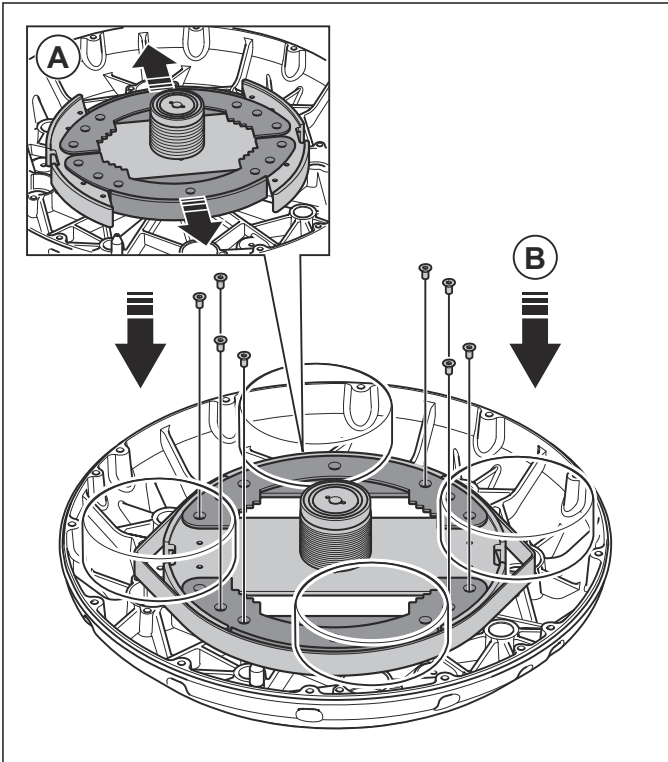

9. Install the washers.

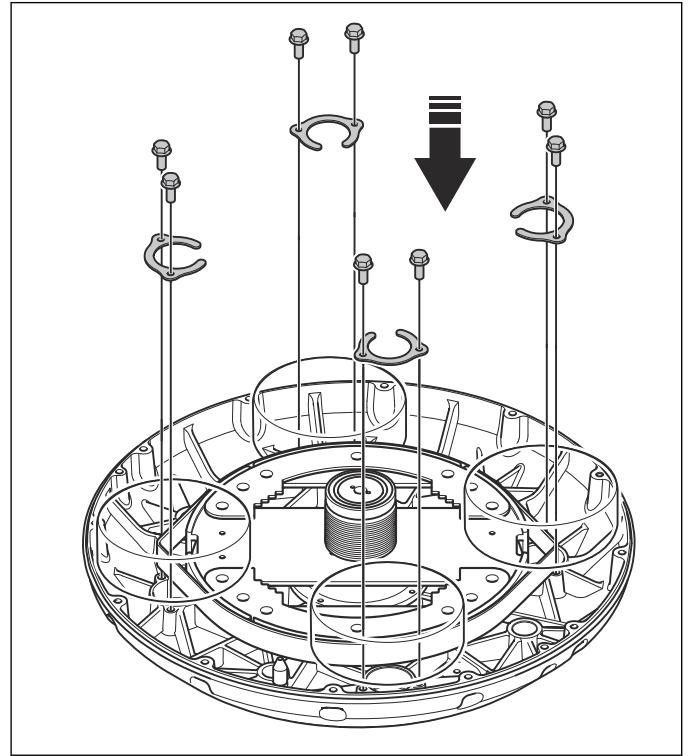

7.7.3 To disassemble the hub assembly

1. Put the hub assembly in the hub pulley tool.

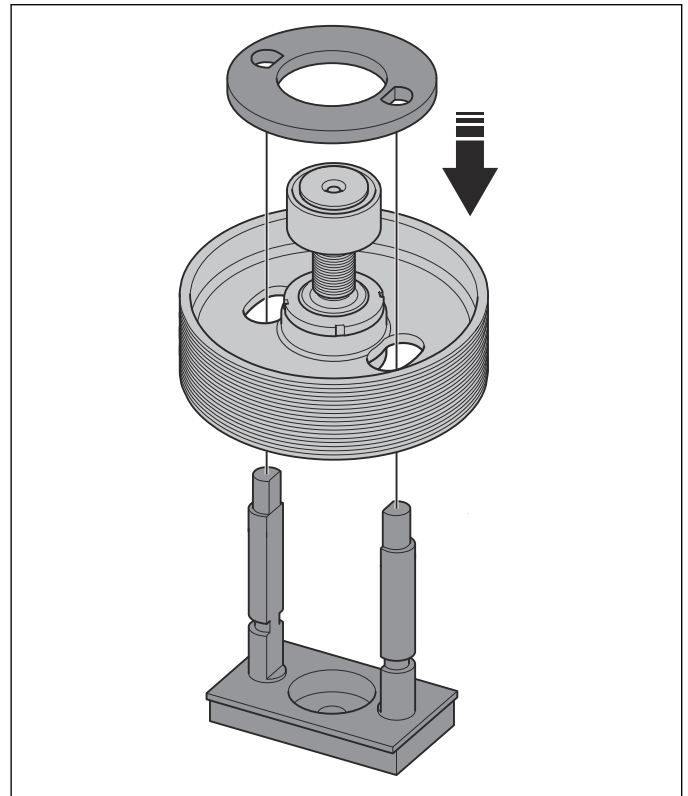

Tool number: 593 53 68-01

2. Install the bearing extractor bracket.

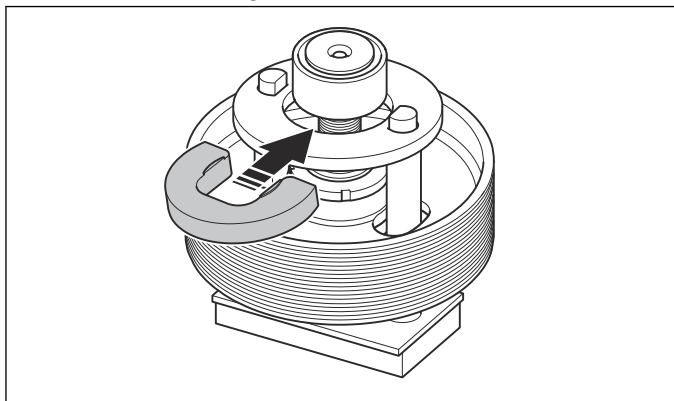

Tool number: 593 54 52-01

3. Put the assembly in a press. Push in the bearing with the mandrel.

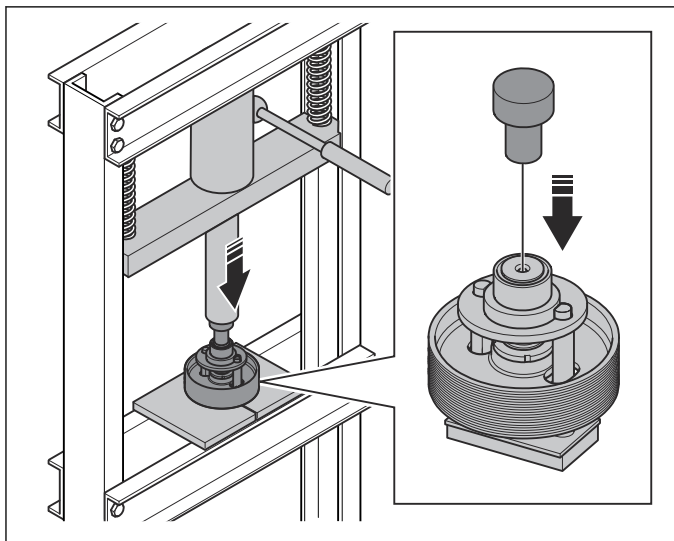

4. Remove the pulley.

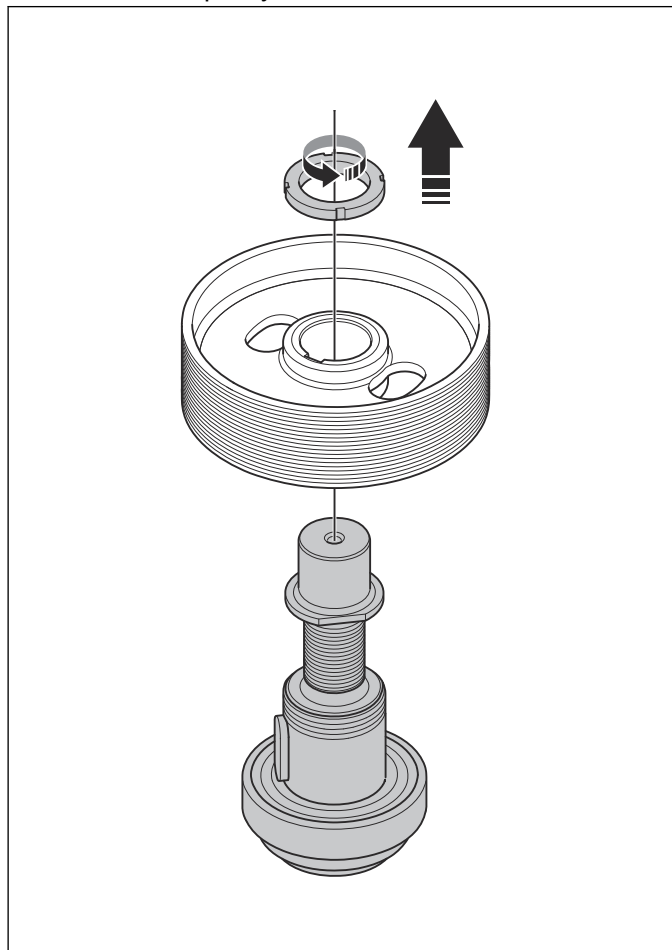

5. Put the shaft on the support.

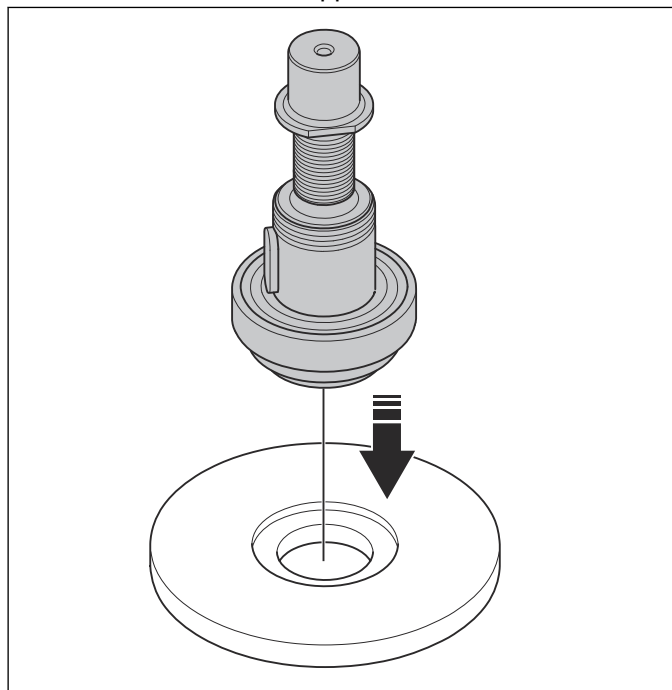

Tool number: 593 54 43-01

6. Remove the bearing with a press.

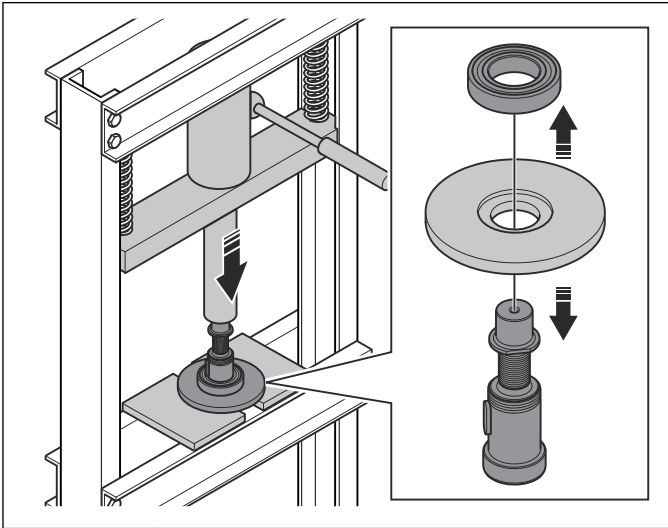

7.7.4 To assemble the hub assembly

1. Push the bearing onto the hub assembly. Use a force of 2000 kg. Use a press tool.

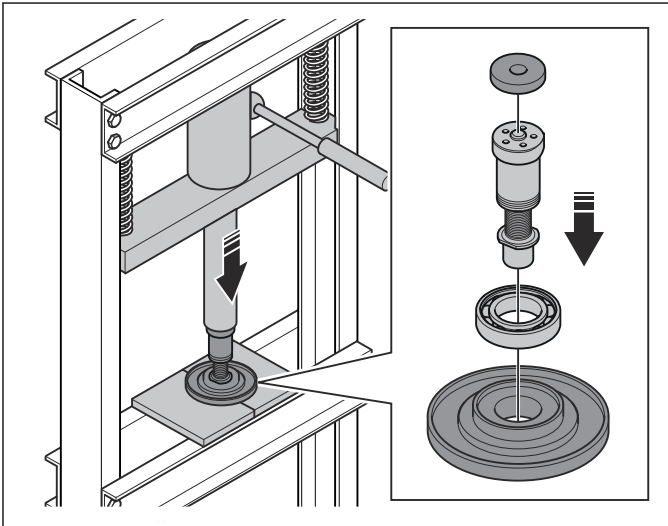

Tool number: 593 54 16-01

2. Push the pulley wheel onto the grinding shaft. Use a force of 2000 kg.

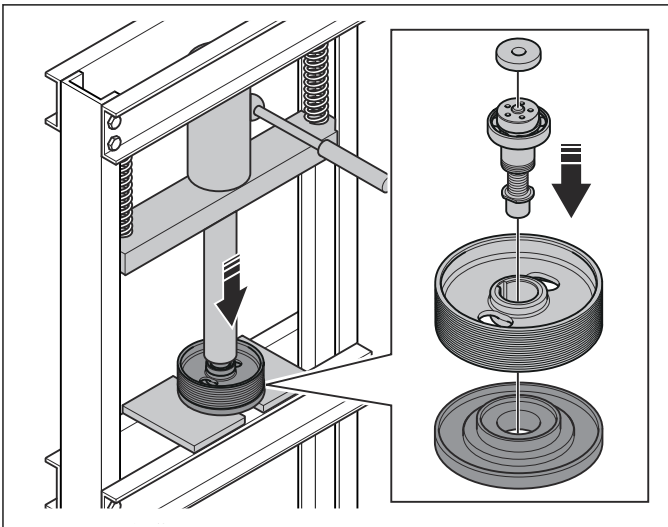

3. Put the hub assembly, the nut and the socket in the tool.

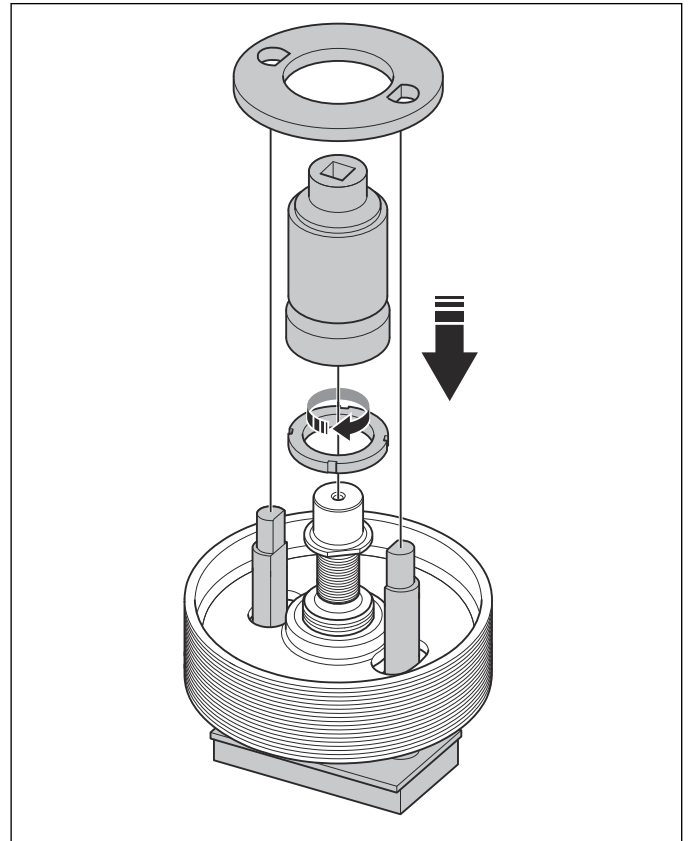

Tool number: 593 54 17-01

4. Tighten the nut with a torque wrench.

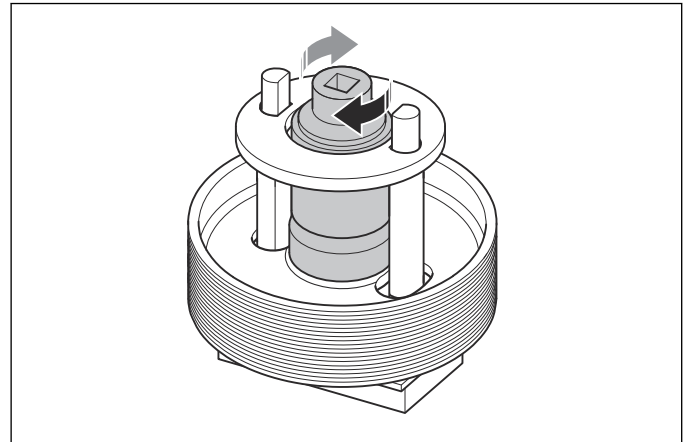

5. Push the bearing with a support and a mandrel.

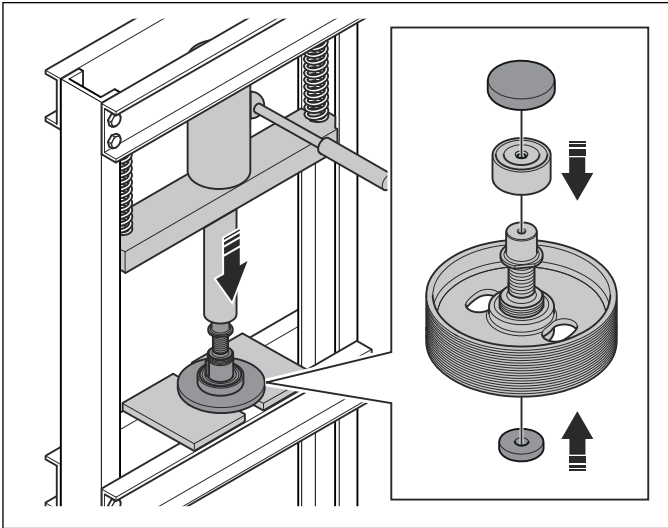

Tool number: 593 54 18-01

6. Install the washer and the nut.

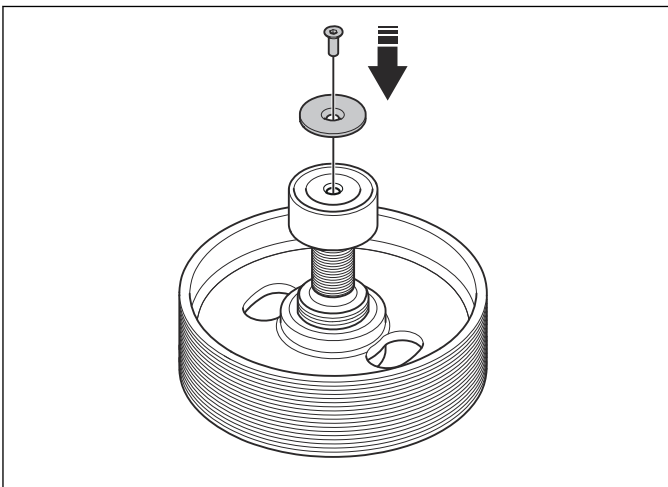

7.8 Secondary pulley

7.8.1 To remove the secondary pulley

1. Remove the screws for the secondary pulley.

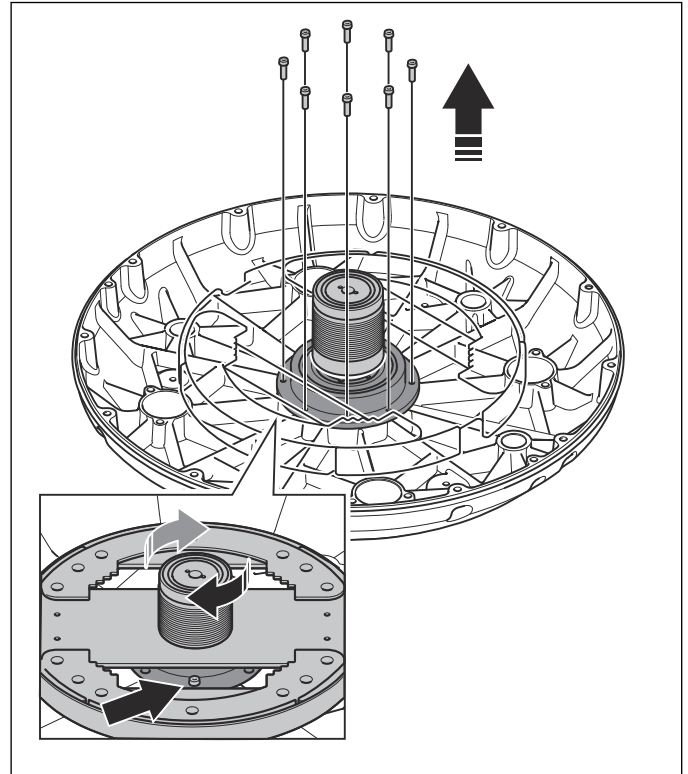

2. Remove the secondary pulley.

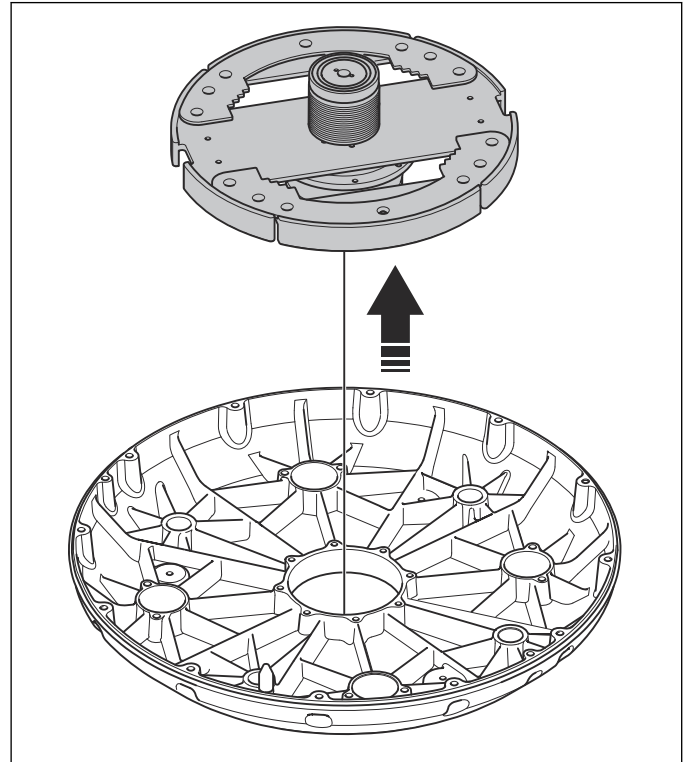

7.8.2 To install the secondary pulley

1. Install the secondary pulley.

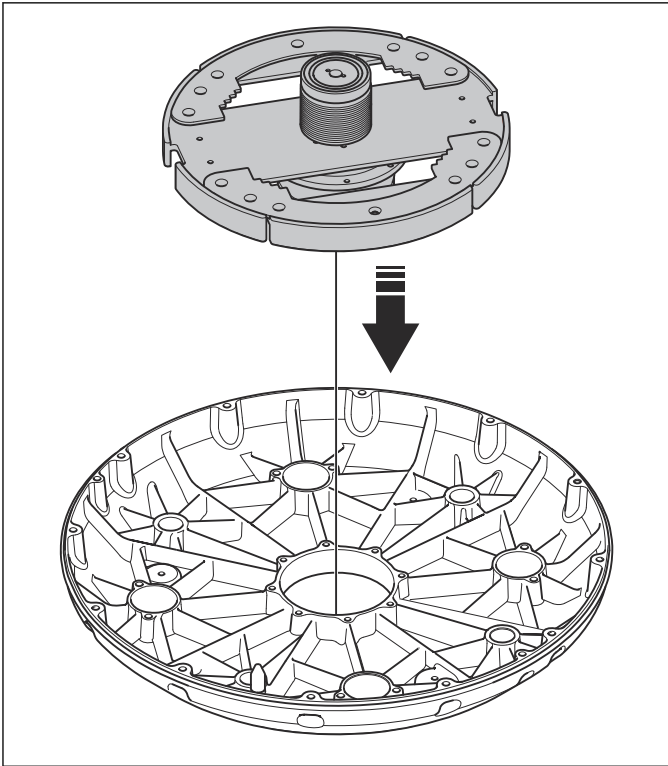

2. Install the screws.

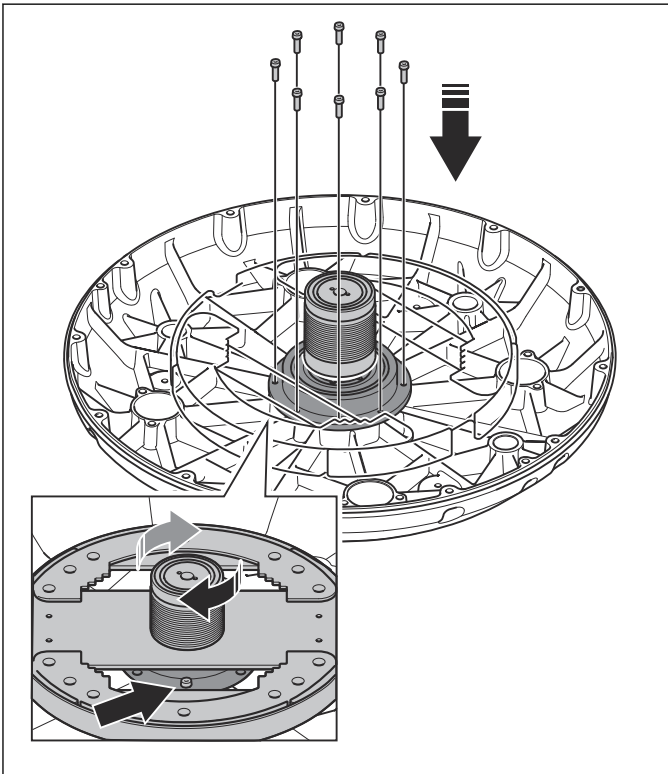

7.8.3 To disassemble the secondary pulley

1. Remove the bearing from the pulley center.

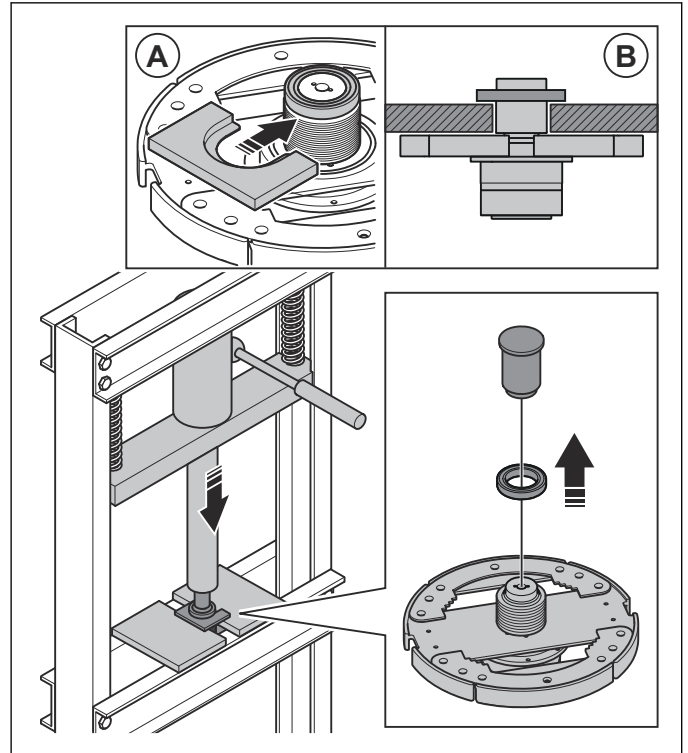

Tool number: 593 54 30-01

2. Remove the snap ring.

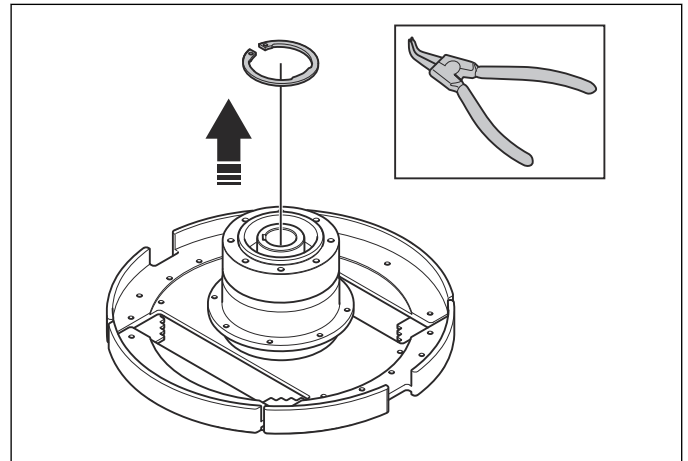

3. Push out the center pulley. Make sure that there is support below the area of the center hub.

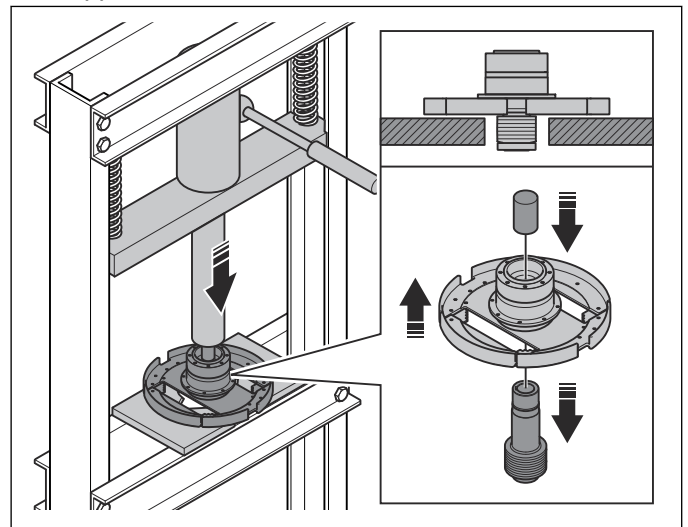

4. Push out the inner center hub.

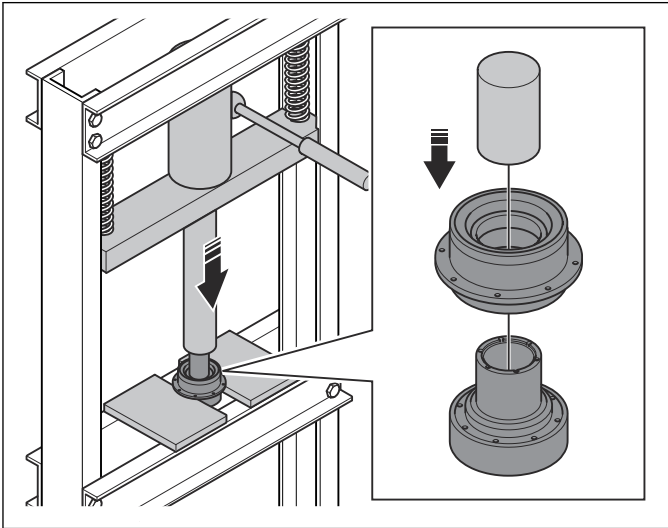

7. Remove the bearing with a mandrel.

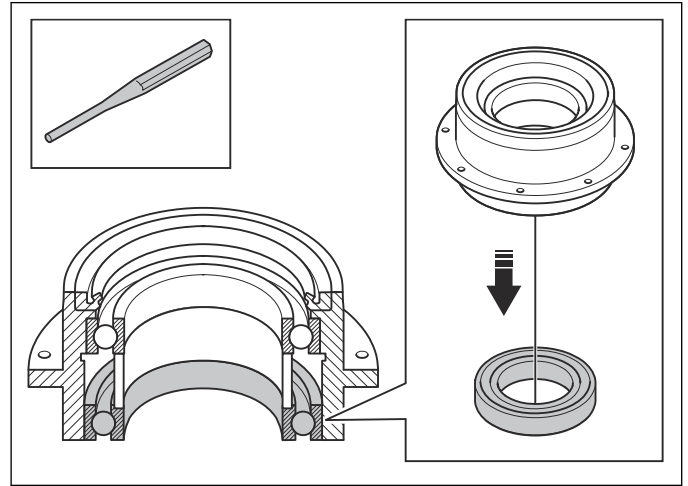

5. Remove the snap ring.

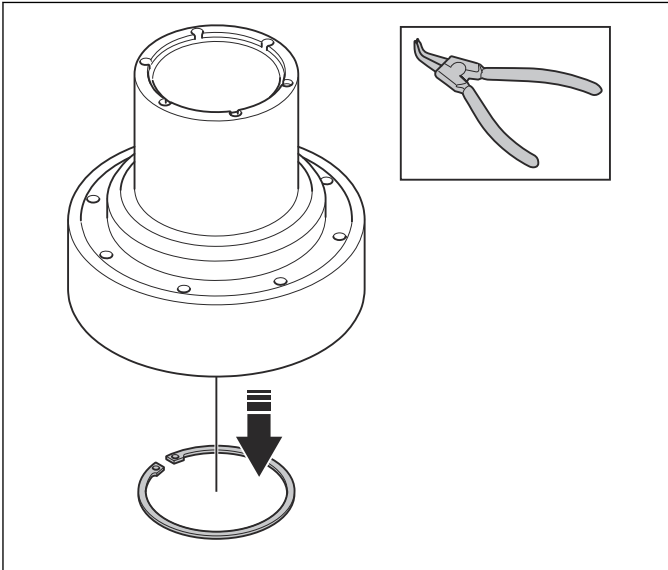

8. Remove the snap ring.

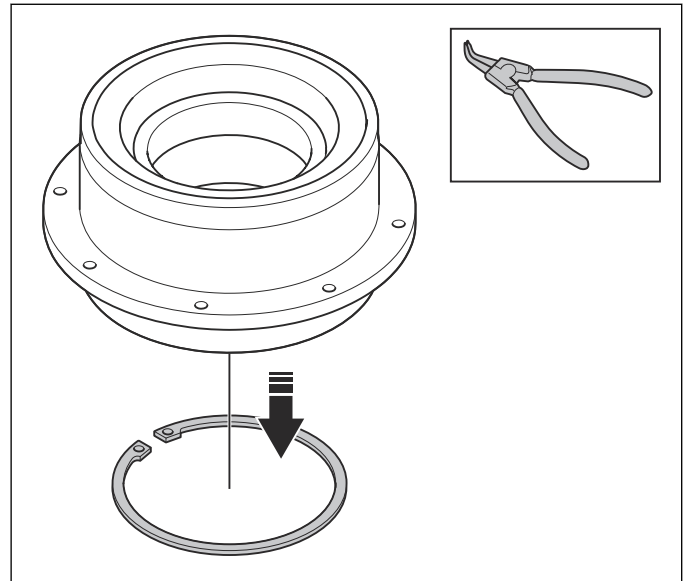

6. Remove the bearing.

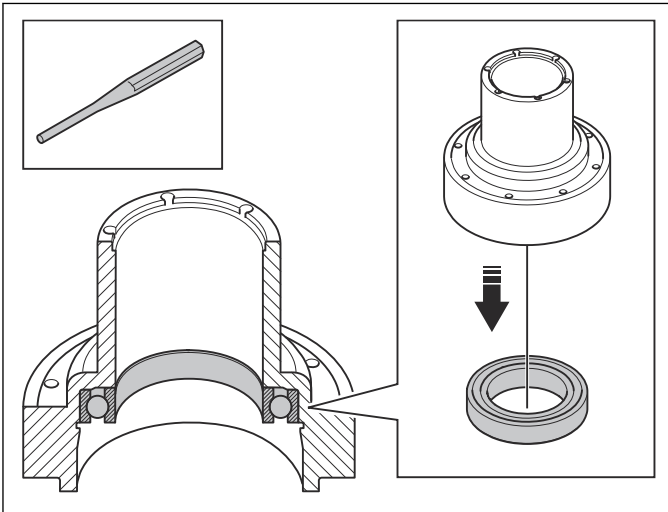

9. Remove the spacer.

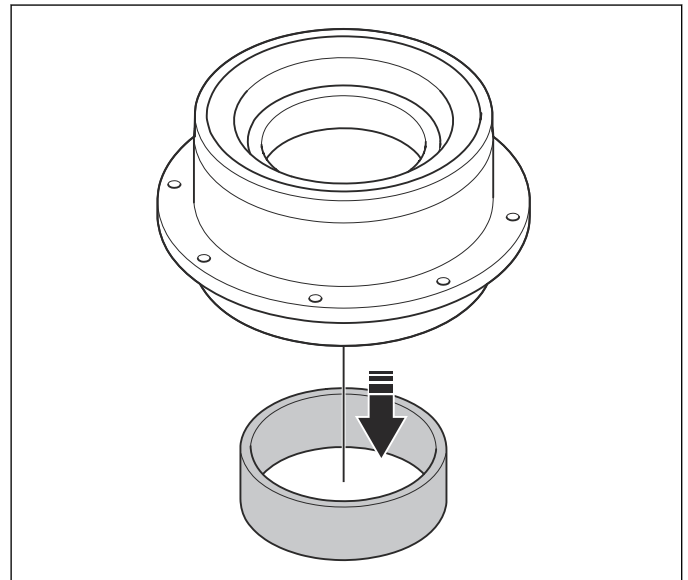

10. Remove the second bearing with a mandrel.

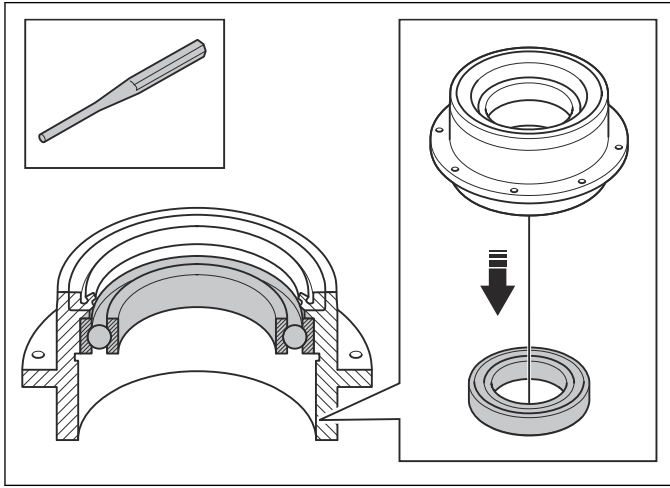

7.8.4 To assemble the secondary pulley

1. Push the bearing into the outer center hub with a force of 2000 kg.

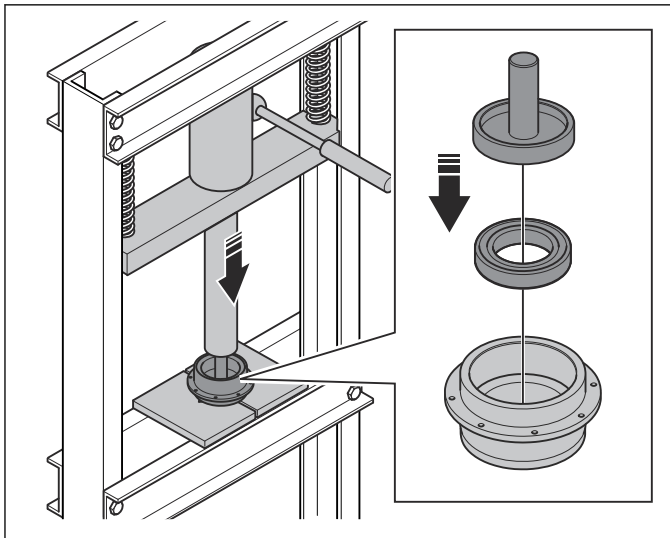

Tool number: 593 54 09-01

2. Install the snap ring.

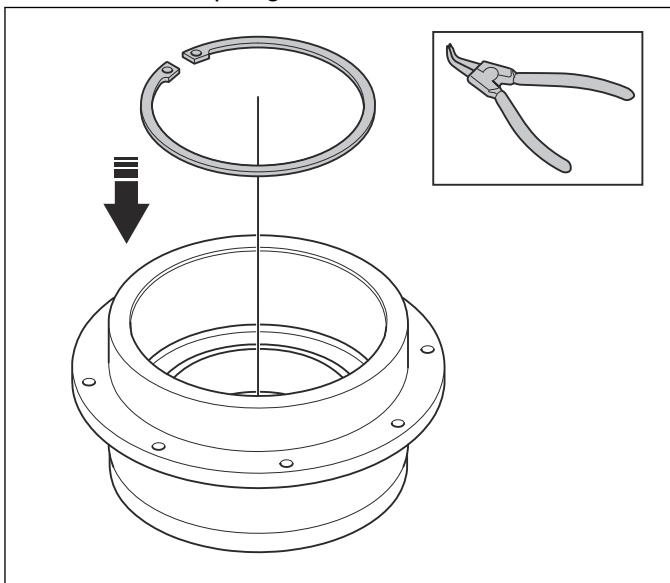

3. Install the spacer.

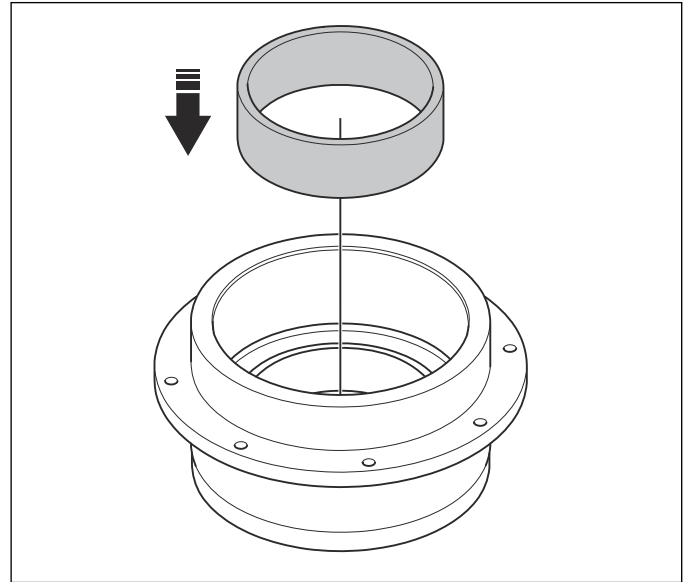

4. Push the bearing with a force of 2000 kg.

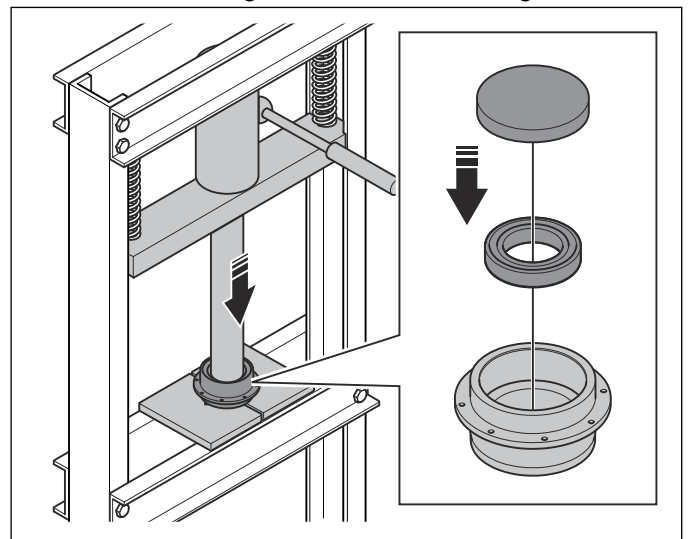

Tool number: 595 75 94-01

5. Push the radial seal with a force of 2000 kg.

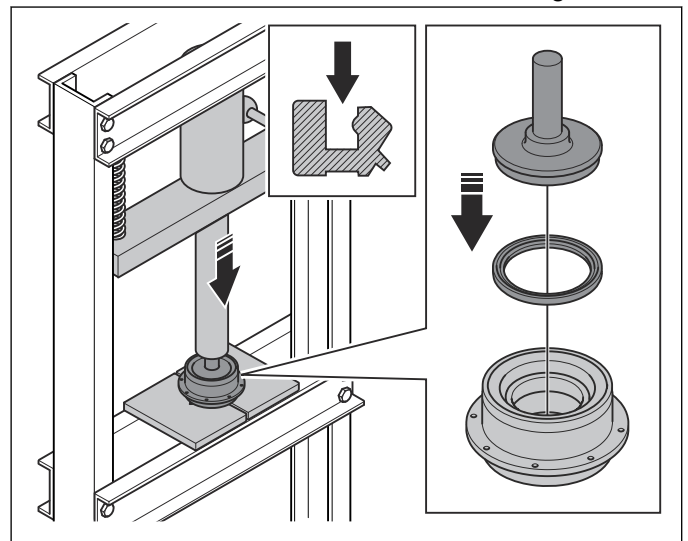

Note: Make sure that the flat side of the radial shaft seal points down into the center hub.

Tool number: 593 54 11-01

6. Put grease on the radial seal.

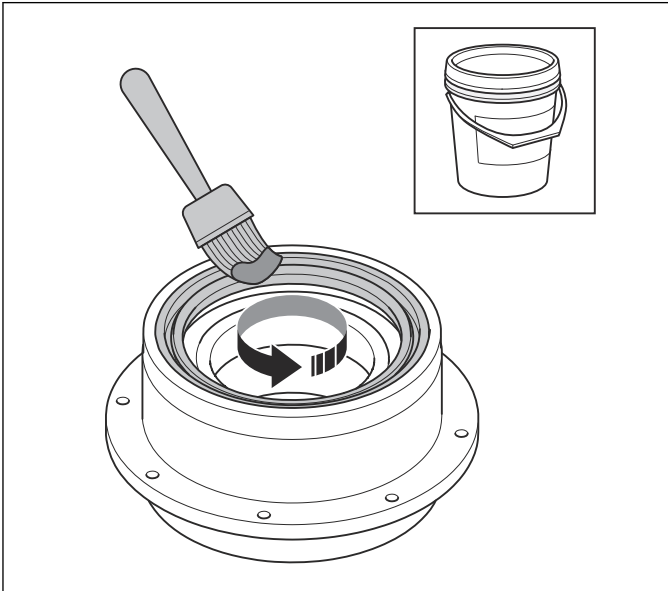

Use Molykote W2 Multipurpose grease

7. Push the bearing into the center hub.

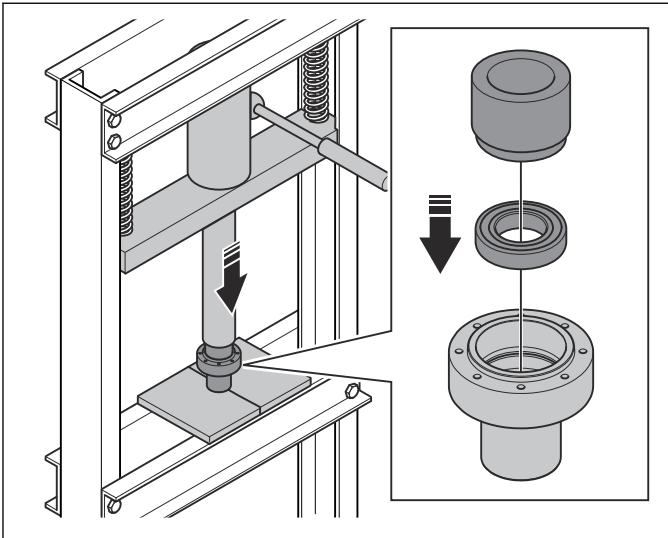

Tool number: 593 54 12-01.

8. Install the snap ring.

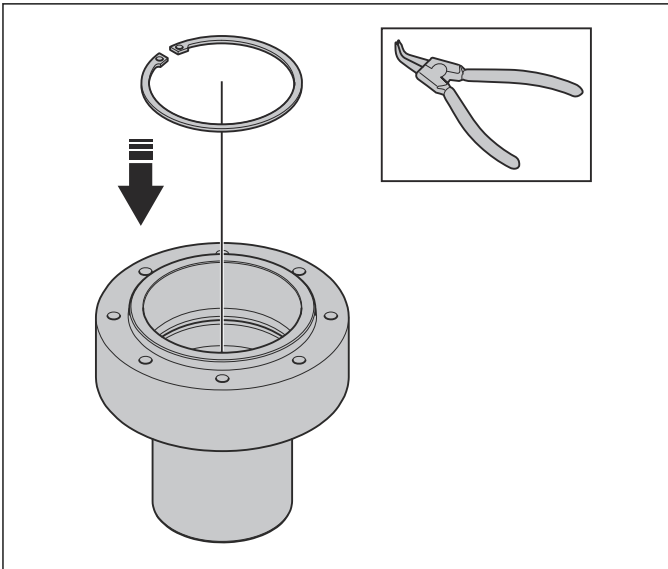

9. Push the inner and outer center hubs. Use the support cone and support.

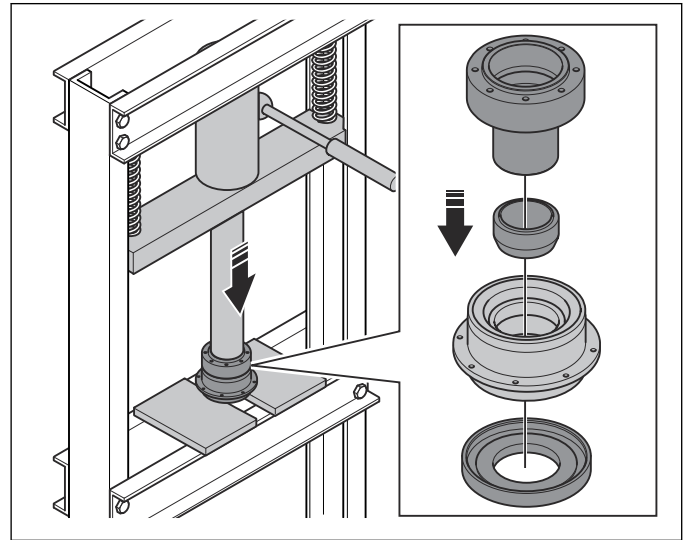

Tool numbers: 593 54 51-01, 593 54 13-01.

10. Assemble the secondary pulley.

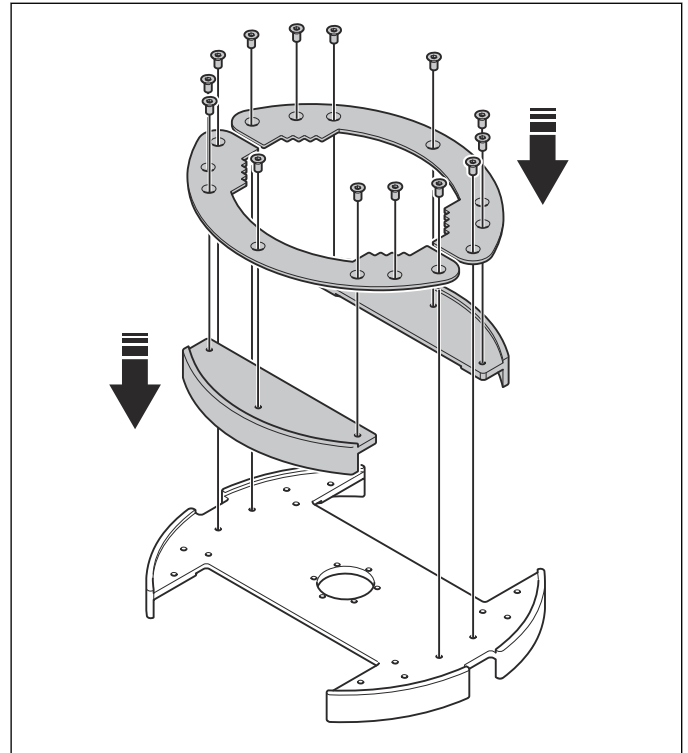

11. Install the secondary pulley on the center hub.

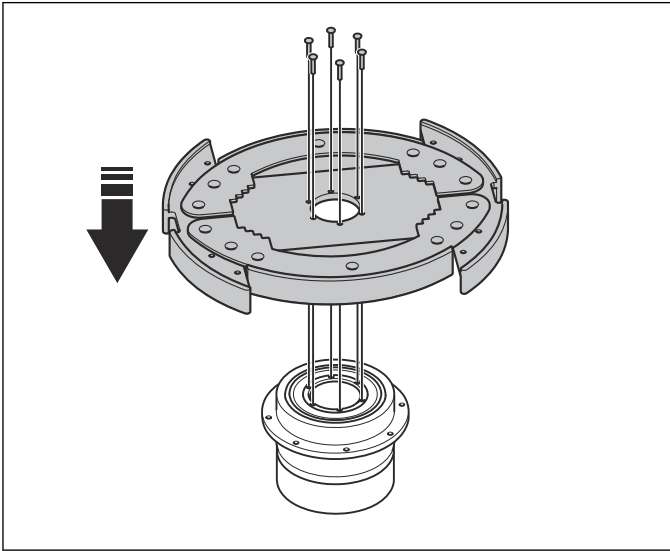

12. Push the bearing onto the center pulley.

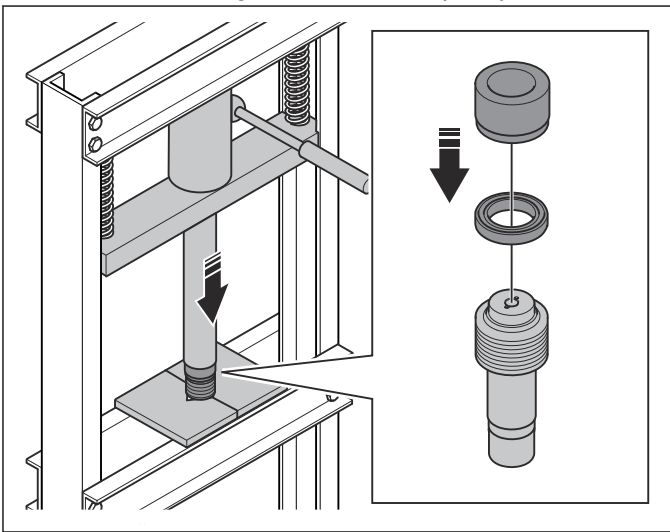

Tool number: 593 54 12-01

13. Push the center pulley into the center hub.

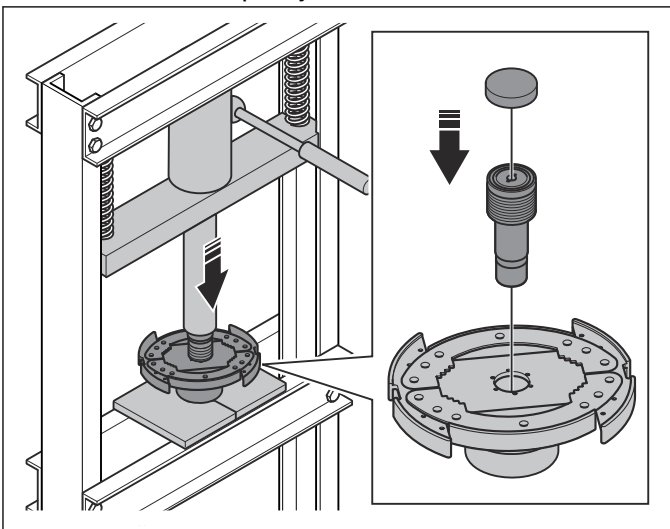

Tool number: 593 54 14-01

14. Install the snap ring.

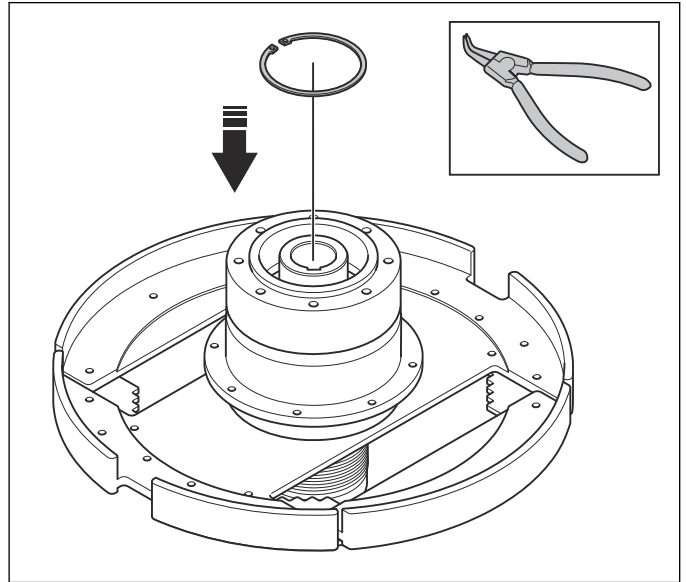

7.9 Idle pulleys

7.9.1 To disassemble the idle pulleys

1. Remove the idle pulley.

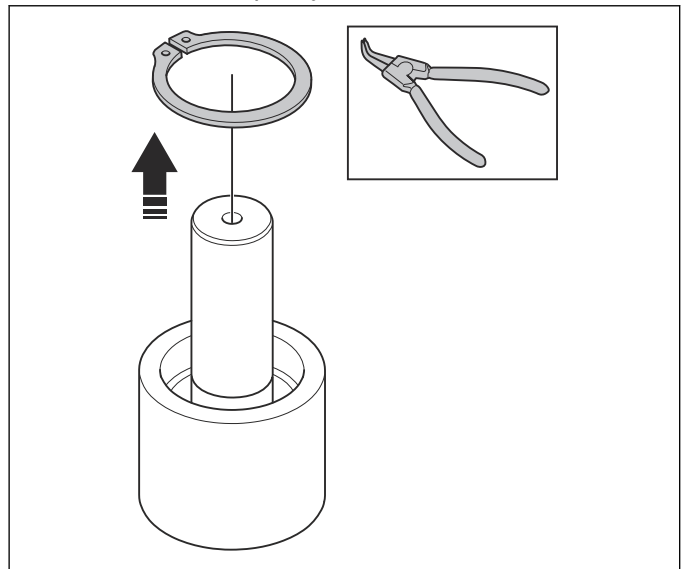

2. Remove the shaft with a press. Use a mandrel with a maximum diameter of 16 mm.

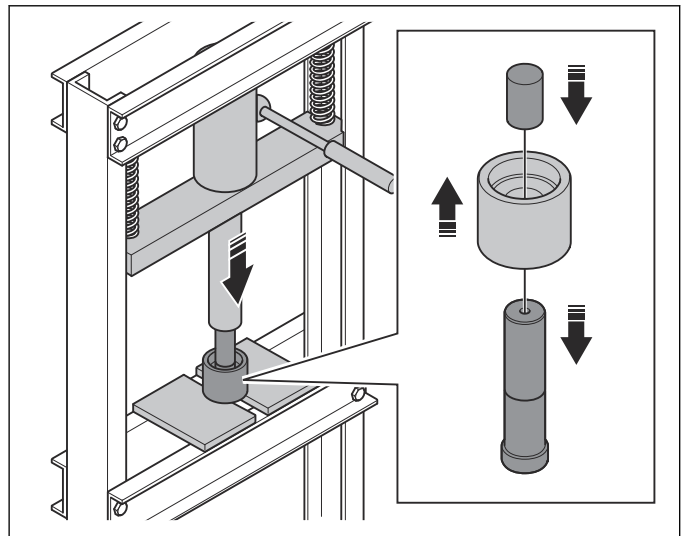

3. Remove the bearings with a mandrel.

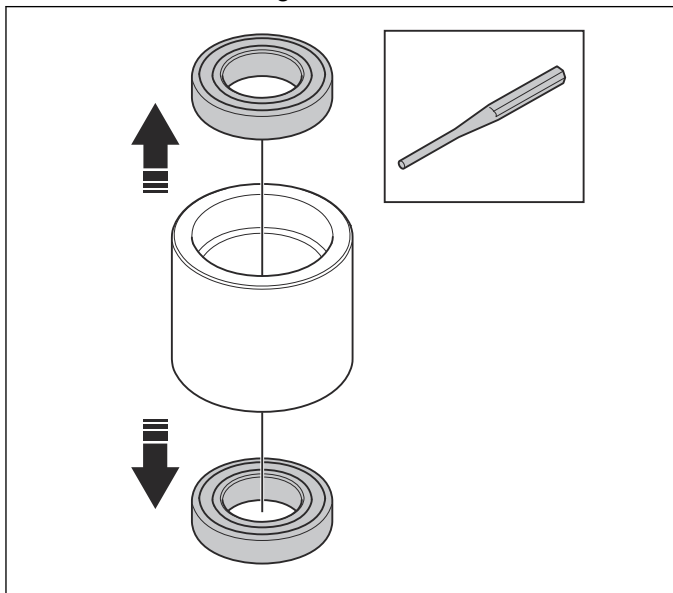

Tool number: 593 54 19-01

2. Install the shaft and the snap ring.

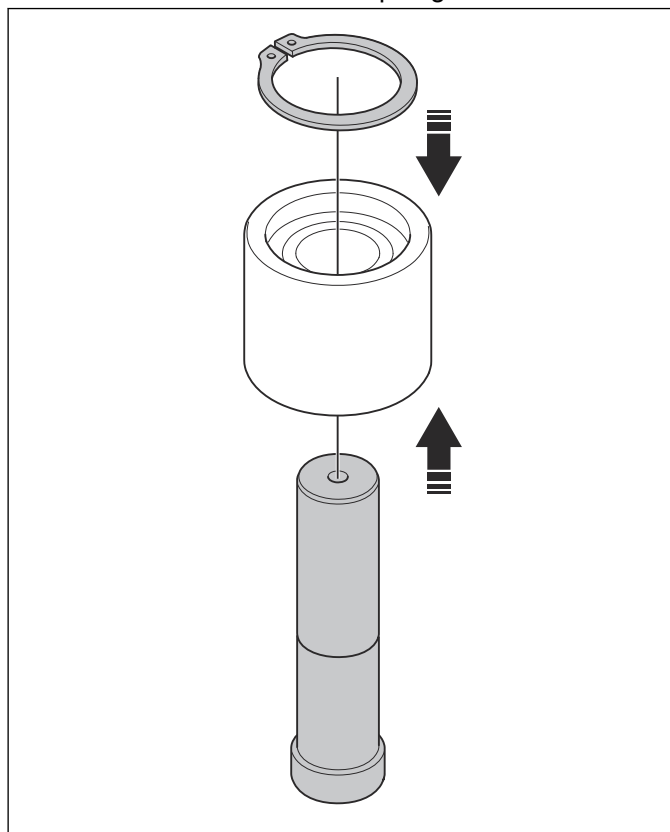

7.9.2 To assemble the idle pulleys

1. Push the bearings with the mandrel. Use a force of 2000 kg.

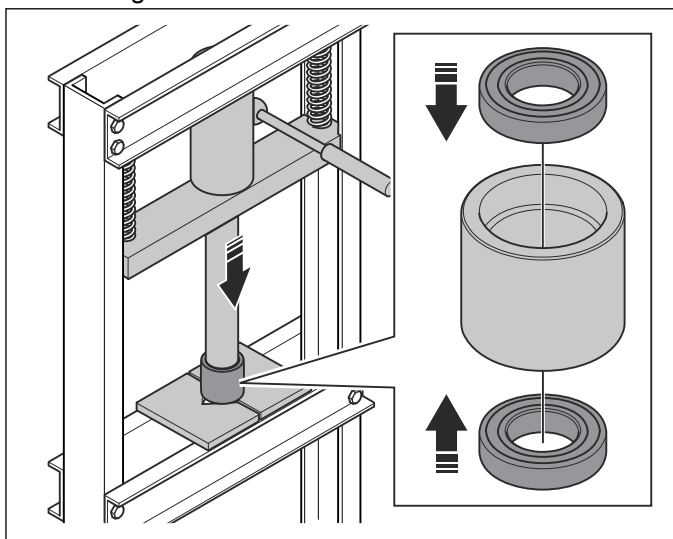

7.10 S-key

7.10.1 To replace the S-key

The S-key and the receiver card are purchased as a kit. The 2 units must be replaced at the same time.

1. Open the receiver for the remote control and replace the receiver card.

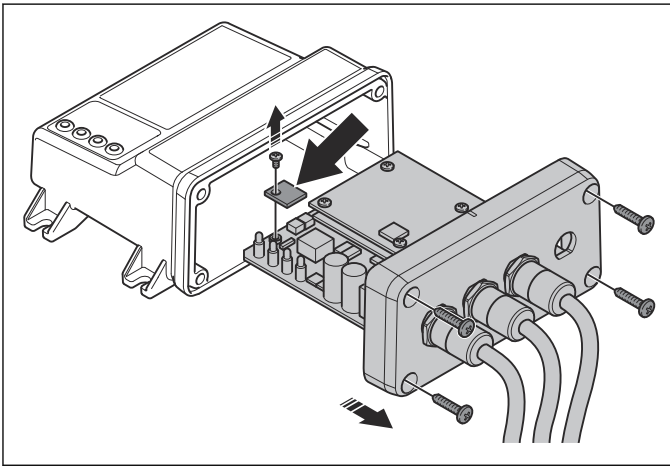

2. Turn the key counterclockwise and pull it straight out.

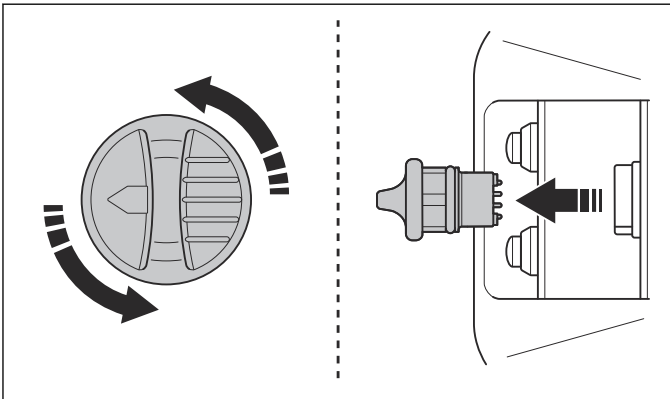

3. Make sure that the receiver has power and is started.
4. Push the emergency stop button on the remote control.

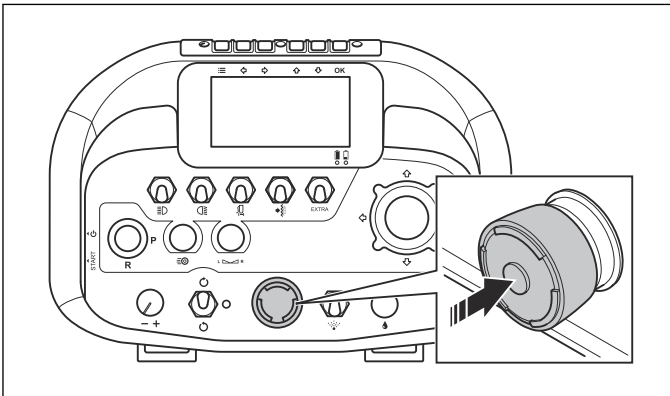

5. Push in the new S-key and turn it clockwise.

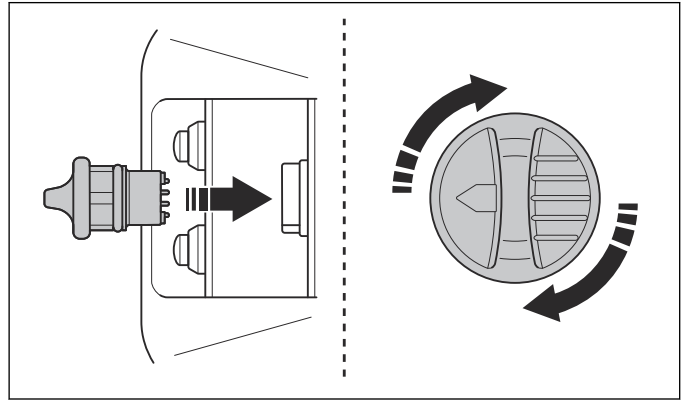

6. Turn the emergency stop button clockwise to reset it.

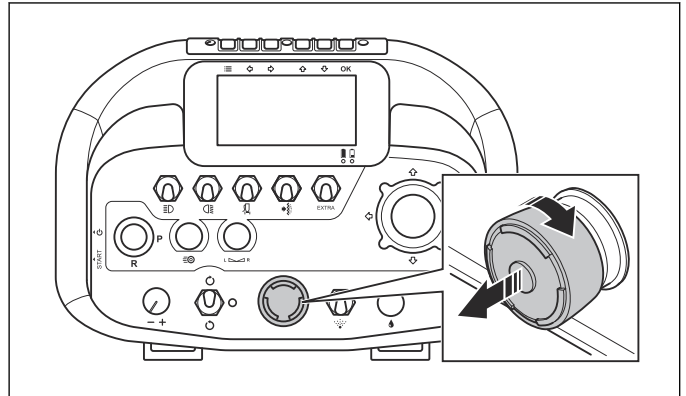

7. Push and hold down the green button until the green LED starts to flash slowly.

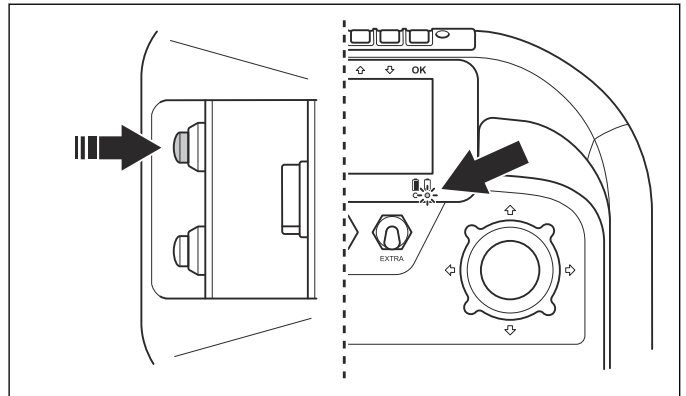

8 Troubleshooting

8.1 General

Problem	Cause	Solution
Error code is shown on the display.	1 of the alarm systems of the product is started.	For more information refer to <i>Display overview on page 24</i> .
The product has no connection with other units.	The CAN bus signal is broken.	Do a check of the cable connections on the connection panel.

8.2 The product does not start

Problem	Cause	Solution
The product does not start	Fault on the electrical supply, for example fuses, RCDs or the connected cables.	Do a check that the voltage is correct on the incoming phase/phases.
	Fault on the power supply. The power supply indication is not on.	Do a check of the small switch F1.
	Fault on the power supply. Low output voltage.	Must be 27.2—27.5V. Refer to the display.
	Fault on the main circuit board. The main circuit board is not on.	Do a check of the fuse.
	Fault on the battery. Low battery voltage.	Must be 23-26V.
	Fault on the fuses. Standby LED on the control panel is not on.	Do a check of the fuse F2 and F8.

8.3 The fuses break or the RCD opens frequently

Problem	Cause	Solution
RCD opens.	The RCD, EMC filter, cable harness or converter is defective.	Do a check of the RCD, EMC filter, cable harness and converter.
Fuses break.	Too high load or too small fuses.	Do a check of the fuses and the current inertia.
		Decrease the load of the product by lower the grinding pressure, lower the speed or make a change of tool. Refer to the power meter of the product.
		Do a check of the capacity of the fuses.

8.4 The product does not operate correctly

Problem	Cause	Solution
The product does not operate correctly.	Too high load.	Decrease the grinding pressure.
		If the product operates at high speed, lower the speed and the product becomes stronger. Refer to r/m for available power.
		Do a check of the voltage meter during operation.
	Do a check of the tools. Use the correct tools and make sure that they are correctly installed.	
	The surface is tacky.	Operate half of the grinding head on the surface to be cleaned and half on the clean surface. This removes remaining waste on the tools.

8.5 Error codes

The error messages and warnings are shown on the display on the product and/or the remote control.







The display shows an error symbol and a description for the error.

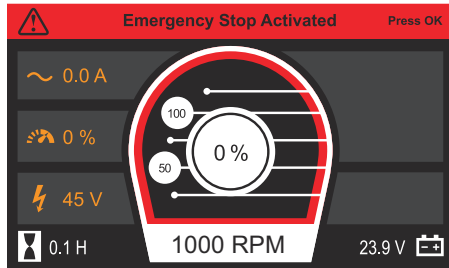



If the error message is yellow, you can continue to operate the product.

If the error message is red, the product stops.

Push "OK" to reset the error. The error is recorded in the error code record of the product.



Symbol	Cause	Solution
	Low control voltage.	Do a check of the power supply unit.
	The voltage is low on a movement motor.	Do a check of the control voltage. Do a check of the battery voltage. Do a check of the cables to the motors. Do a check of the voltage on relay outputs.
	The voltage is low on the receiver for the remote control.	Do a check of the control voltage. Do a check of the battery voltage. Do a check of the cable to the receiver for the remote control.
	Converter error.	Go to the support web site.
	Error on CAN bus.	Do a check of the cables. Do a check of the units that is connected to HMI.
	General error converter, remote control, left/right movement motor.	Go to the support web site.
	The converter overloads.	Let the product become cool.
	The frequency converter is too hot.	Do a check of the function of the fans. Clean the fans and the flanges. Check voltage level during operation. Decrease the pressure on the grind unit.
	The flange for the frequency converter is too hot.	Let the frequency converter become cool.
	The grinding motor overloads. The gauge shows more than 90%.	Decrease the motor load, refer to the gauge for the motor current.
	The grinding motor overloads. The gauge shows near 100%.	Let the product become cool.
	The grinding motor is too hot.	Do a check of the cooling fan of the motor. Decrease the motor load, refer to the gauge for the motor current.
	The temperature is too high in the electrical box.	Clean the fans and the flanges. Make sure that the fans rotate correctly. The fans must rotate during operation and 1 minute after completed operation. Let the product become cool.

Symbol	Cause	Solution
	A servicing of the product is necessary.	Orange symbol: Servicing is necessary in the next 50 hours or 2 weeks. Red symbol: Servicing is not done in time. Speak to your servicing dealer.
	The water is low in the water tank.	Fill water in the watertank. Do a check of the level sensor.
	The input voltage is too high.	Error on the power supply.
	Low input voltage to the product.	Do a check of the voltage level during operation. Do a check of the cable area. Do a check of the electrical supply.
	Low voltage.	Do a check of the cable area and cable length. Error on power supply. Emergency stop is on.
	The emergency stop is on.	Reset the emergency stop.
	General error converter, remote control, left/right movement motor.	Go to the support web site.
	Break in grinding motor or the grinding motor cables.	Do a check of the grinding motor cables. Do a check of the grinding motor.
	There is a short circuit in the grinding motor.	Do a check of the grinding motor cables.
	Phase error power supply.	One or more phases has no current supply. Do a check of the current supply.

9 Diagrams

9.1 Wiring diagram, electric box

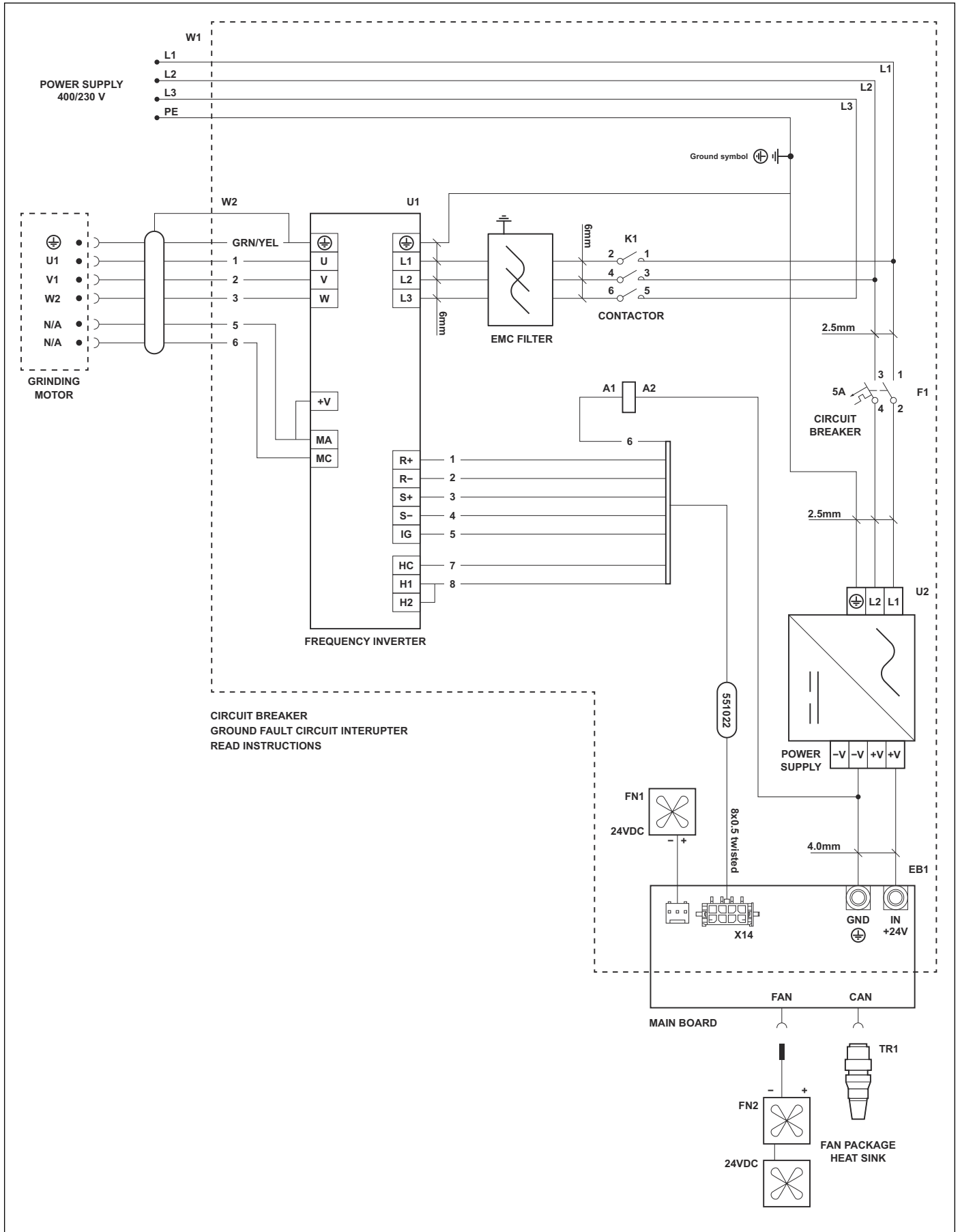

9.2 Wiring diagram, main circuit board

