

Workshop manual

**DE 110 H, DE 110SH, DE 110i H, DE
120 H, DE 120 H PACE**



English

Contents

1 Introduction

1.1 Document description.....	3
1.2 Target group.....	3
1.3 Revisions.....	3
1.4 Safety.....	3

2 Safety

2.1 Safety definitions.....	4
2.2 General safety instructions.....	4
2.3 Special safety instructions.....	4
2.4 Battery safety.....	4
2.5 Battery charger safety.....	5
2.6 Symbols on the product.....	5

3 Prepare and do servicing on the product

3.1 Maintenance schedule	7
3.2 To clean the product.....	7

4 Servicing data

4.1 Prefilter cover	8
4.2 HEPA filter cover, control panel and power cable lid.....	9
4.3 HEPA filter.....	10
4.4 Chassis and wheels.....	11
4.5 Prefilter container.....	12

5 Function overview

5.1 Type plate and product serial number.....	13
5.2 Type plate.....	13

6 Product overview for repair and servicing

6.1 Product overview.....	14
---------------------------	----

7 Firmware

7.1 To do an update of the main circuit board.....	15
--	----

8 Repair and servicing

8.1 To clean and examine the product parts.....	16
8.2 Prefilter.....	16
8.3 HEPA filter.....	17
8.4 Power cord.....	18
8.5 Circuit board.....	20
8.6 Chassis.....	21
8.7 Container.....	22
8.8 Battery.....	24
8.9 Motor.....	24

9 Troubleshooting

9.1 To connect the Husqvarna Service Hub.....	27
9.2 To do troubleshooting of Husqvarna Service Hub (HSH).....	27
9.3 Troubleshooting schedule.....	27
9.4 Warnings on the control panel	28
9.5 Error codes.....	29

10 Diagrams

10.1 Wiring diagram DE 110 SH, EU/AUS/BR.....	30
10.2 Wiring diagram DE 110 SH, EU/AUS.....	31
10.3 Wiring diagram DE 110 SH, US/UK/JPN.....	32
10.4 Wiring diagram DE 110 SH, US/UK/JPN.....	33
10.5 Wiring diagram DE 110i H.....	34
10.6 Wiring diagram DE 110 H, EU/AUS.....	35
10.7 Wiring diagram DE 110 H, EU/AUS.....	36
10.8 Wiring diagram DE 110 H, UK/JP/US.....	37
10.9 Wiring diagram DE 110 H, UK.....	38
10.10 Wiring diagram DE 110 H, JP.....	39
10.11 Wiring diagram DE 110 H, US.....	40
10.12 Wiring diagram DE 120 H EU/AUS.....	41
10.13 Wiring diagram DE 120 H EU/AUS/UK.....	42
10.14 Wiring diagram DE 120 H US/JP.....	43
10.15 Wiring diagram DE 120 H PACE.....	44
10.16 Wiring diagram DE 120 H PACE.....	45

11 Technical data

11.1 Technical data DE 110i H EU.....	46
11.2 Technical data DE 110i H US.....	46
11.3 Technical data DE 110 SH, DE 110 H, DE 120 H EU.....	47
11.4 Technical data DE 110 SH, DE 110 H, DE 120 H US.....	48
11.5 Technical data DE 110 SH, DE 110 H, DE 120 H JA.....	49
11.6 Technical data DE 120 H PACE.....	50

1 Introduction

1.1 Document description

This manual gives a full description of how to do maintenance and repair on the product. It also gives safety instructions that the personnel must obey.

1.2 Target group

This manual is for personnel with a general knowledge of how to do repair and do servicing. All personnel that do repair or do servicing on the product must read and understand the manual.

1.3 Revisions

Changes to the product can cause changes to the maintenance work and spare parts. Separate information is sent out for each change.

Read the manual together with all received information about changes to maintenance and spare parts for the product.

1.4 Safety



WARNING: All personnel that repair or do servicing on the product must read and understand the safety instructions in this workshop manual.

2 Safety

2.1 Safety definitions

Warnings, cautions and notes are used to point out specially important parts of the manual.



WARNING: Used if there is a risk of injury or death for the operator or bystanders if the instructions in the manual are not obeyed.



CAUTION: Used if there is a risk of damage to the product, other materials or the adjacent area if the instructions in the manual are not obeyed.

Note: Used to give more information that is necessary in a given situation.

2.2 General safety instructions

- You must obey the safety instructions.
- You must prevent situations that can cause damage or injury.
- You must read the workshop manual before you do work on the product.
- You must read the operator's manual if you operate the product.
- Do not use a damaged product.
- Do not do work on the product if you have health problems that can cause dangerous situations.
- Do not use the product if you are tired, ill, or under the influence of alcohol, drugs or medicine.
- Do not touch the product if your hands are wet.
- Make sure that only approved persons can come near the product.
- Replace all damaged or missing warning symbol decals.

2.3 Special safety instructions



WARNING: Read the warning instructions that follow before you use the product.

- Refer to local regulations and clean the product before you do servicing.
- Find out the type of dust the product has been used for. If the product has been used to asbestos, make sure to clean it according to applicable directive.
- Obey all applicable laws and regulations. If it is necessary, speak to a third party quality decontamination company to discard the waste products.
- Stop the motor and disconnect the power cord or remove the battery before you do servicing unless the instructions in this manual tell you differently.
- Let an approved electrician do all checks on the electric components.
- Do not do servicing of the batteries.

- Do not open the enclosure on a battery product. Do not operate a damaged battery product. There is a risk of electrical shock.
- Do not connect a battery to a damaged product. If the product is damaged during operation, remove the battery from the product and speak to your Husqvarna service center.
- Use the correct tightening torque when you torque the screws. The threads in the plastic parts can easily be damaged.
- To lift the product safely, put straps through the lifting eyes. Do not use metal hooks, chains or other lifting equipment with rough edges that can cause damage to the lifting eye. Only soft lifting straps are permitted.

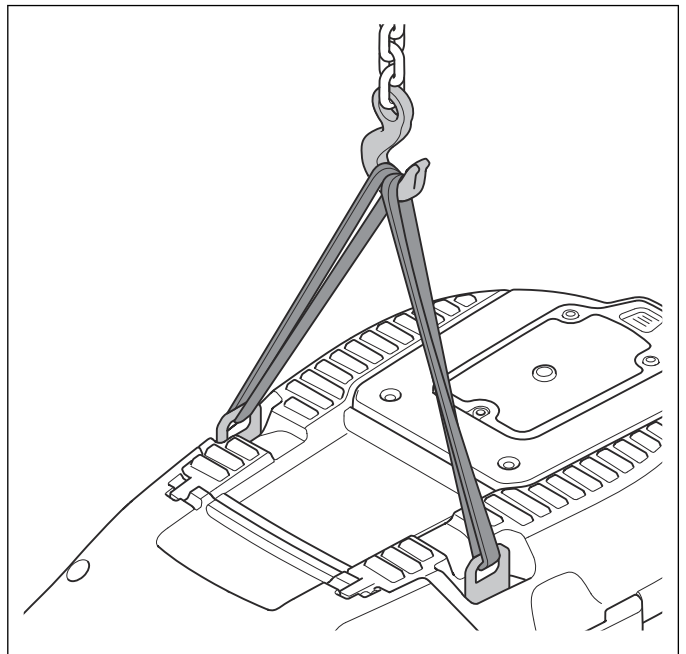

2.4 Battery safety



WARNING: Read the warning instructions that follow before you use the product.



WARNING: A damaged battery can cause an explosion and cause injury. If the battery has a deformation or is damaged, speak to an approved Husqvarna service agent.

- Only use the AGM (Gel) batteries that we recommend for your product. The batteries are software encrypted.
- Use only original batteries for this product. There is a risk of explosion if the batteries are replaced with a battery of incorrect type. Speak to your dealer for more information.
- Use AGM (Gel) batteries that are rechargeable as a power supply for the related Husqvarna products only. To prevent injury, do not use the battery as a power supply for other devices.

- Risk of electrical shock. Do not connect the battery terminals to keys, screws or other metal. This can cause a short circuit of the battery.
- If the battery leaks, do not let the liquid touch your body, clothes or the product. If you touch the liquid, clean the area with a large quantity of water and get medical aid.
- Use protective glasses when you are near batteries. If you get liquid in your eyes, do not rub but flush with water for a minimum of 15 minutes. Get medical aid.
- Do not use batteries that are non-rechargeable.
- Do not do modifications to the battery.
- Do not put objects into the air slots of the battery.
- Keep the battery away from sunlight, heat or open flame. The battery can cause an explosion and cause burns and/or chemical burns.
- Keep the battery away from rain and wet conditions.
- Keep the battery away from microwaves and high pressure.
- Do not try to disassemble or break the battery.
- Use the battery only when the ambient temperature is between -10 °C / 14°F and 40 °C / 104 °F.
- Do not clean the battery or the battery charger with water. Refer to *To clean the product on page 7*.
- Do not use a damaged battery.
- Keep batteries in storage away from metal objects such as nails, screws or jewelry.
- Keep the battery away from children.
- Attach the battery correctly. An incorrectly attached battery can cause a short circuit of the battery.

2.5 Battery charger safety



WARNING: Read all safety warnings and all instructions. Failure to follow the warnings and instructions may result in electrical shock, fire and/or serious injury.

- Risk of electrical shock or short circuit if the safety instructions are not obeyed.
- Do not use other battery chargers than the one supplied for your product. Only use or chargers when you charge Husqvarna replacement batteries AGM (Gel) or .
- Do not try to disassemble the battery charger.
- Do not use a damaged battery charger.
- Do not lift the battery charger by the power cord. To disconnect the battery charger from a mains socket, pull out the plug. Do not pull the power cord.
- Keep all cables and extension leads away from water, oil and sharp edges. Make sure that the cable is not caught between doors, fences or equivalent.
- Do not use the battery charger near flammable materials or materials that can cause corrosion. Make sure that the battery charger is not covered. Pull out the plug to the battery charger if there is smoke or fire.

- Only charge the battery indoors in a location with good airflow and away from sunlight. Do not charge the battery outdoors. Do not charge the battery in wet conditions.
- Only use the battery charger where the temperature is between 5 °C / 41 °F and 40 °C / 104 °F. Use the charger in an environment which has a good airflow, dry and free from dust.
- Do not put objects into the air slots of the battery charger.
- Do not connect the battery charger terminals to metal objects as this can short circuit the battery charger.
- Do not charge non-rechargeable batteries in the battery charger or use them in the machine.
- Use approved mains sockets that are not damaged.

2.6 Symbols on the product



WARNING: This product can be dangerous and cause serious injury or death to the operator or others. Be careful and use the product correctly.



Read the manual carefully and make sure that you understand the instructions before you use the product.



Use approved protective helmet, hearing protection, eye protection and respiratory protection.



Do not use metal hooks, chains or other lifting equipment with rough edges. They can cause damage to the lifting eye. Only use soft lifting straps.



The electrical grounding point on this product is identified by the ground symbol.



Battery slot.



The product is H-classified, certified by a third party according to IEC-60335-2-69, EN-60335-2-69 Annex AA.

This product contains harmful dust. Use correct personal protective equipment. Do not operate the dust extractor without the complete filtration system.



The product is not domestic waste. Recycle it at an approved disposal location for electrical and electronic equipment.



If the product has Bluetooth® wireless technology, the Bluetooth® symbol is on the product name label.

3 Prepare and do servicing on the product

3.1 Maintenance schedule

The maintenance intervals are calculated from daily use of the product. The intervals change if the product is not used daily.

Maintenance	Before each use	Daily	Weekly	When suction is low	Each 6 months or 600 h	Each 12 months or 2000 h
Do the filter purge procedure.	X					
Look for signs of wear or damage of the dust release rubber cone.	X					
DE 110 SH, DE 110 H, DE 120 H: Do a check of the power plug and the power cord.	X					
Look for signs of wear, damage or loose connections of the controls before the unit is connected.	X					
Do a check of the hose and the hose connectors.	X					
Look for signs of wear or damage of the plastic parts.	X					
Do a check of the lifting eyes.	X					
Make sure that the Longopac is correct and that it is correctly attached.		X				
Do a check of the filter purge function.		X				
Do a check of the wheels. Look for damage and bad connections.			X			
Do a check of the filter seals			X			
DE 110i H, DE 120 H PACE: Do a check of the connections between the battery and the product. Do a check of the connection between the battery and the battery charger.				X		
Do the filter purge procedure. If the suction continues to be not sufficient, clean the prefilter with water.				X		
Replace the cleaned prefilter if the suction continues to be not sufficient.				X		X
Replace the HEPA filter.				X	X	
Replace the dust release rubber cone.						X
Replace filter cleaning rubber parts.						X

3.2 To clean the product



WARNING: Clean the product daily to prevent circulation of dangerous dust.

- Clean the product in an applicable area.

- Use approved protective gloves when you clean the product.
- Clean the external surface with a moist cloth.
- Do not use water on electrical components.
- Do not use a high-pressure washer or compressed air to clean the product.

4 Servicing data

4.1 Prefilter cover

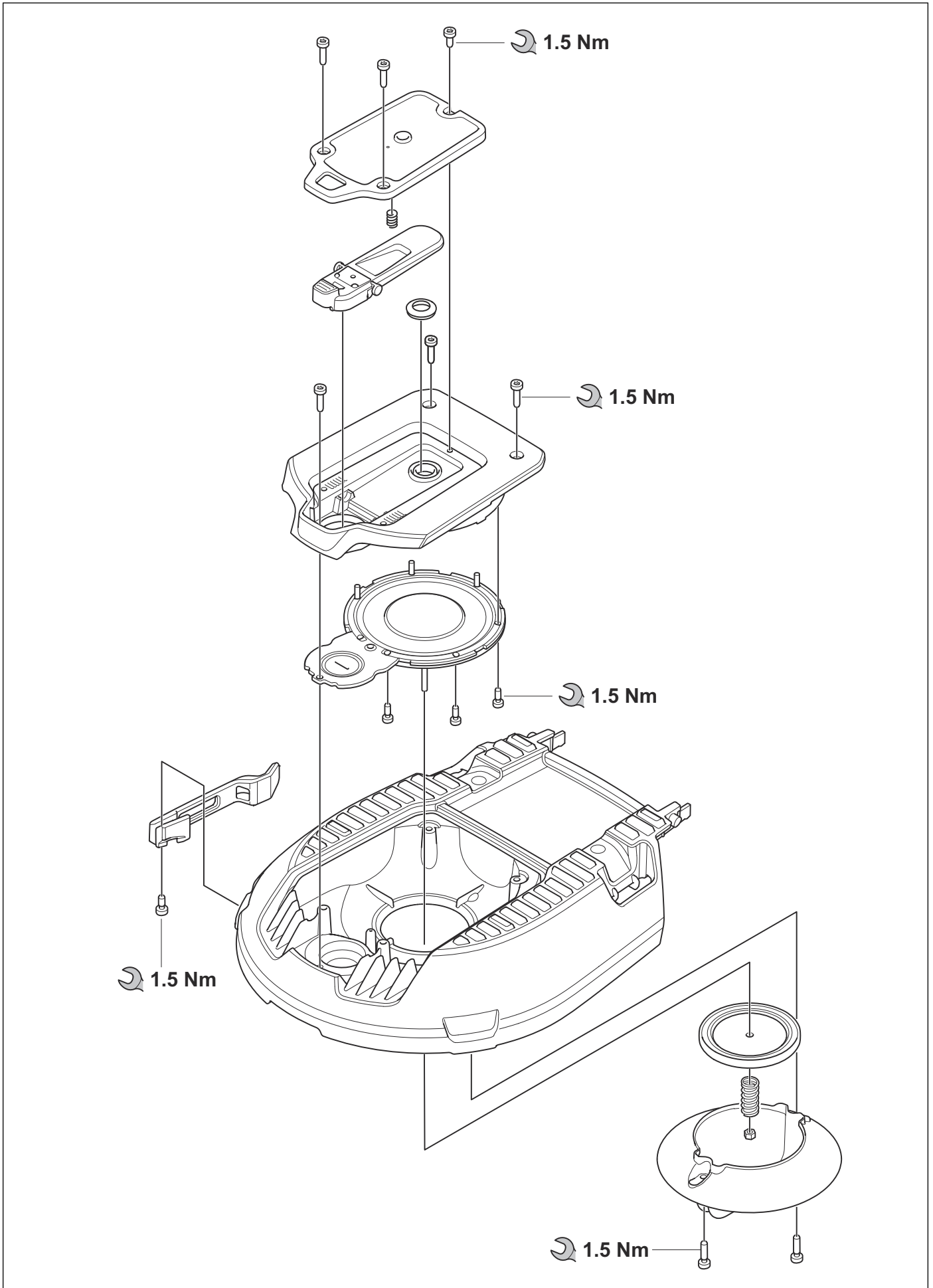

4.2 HEPA filter cover, control panel and power cable lid

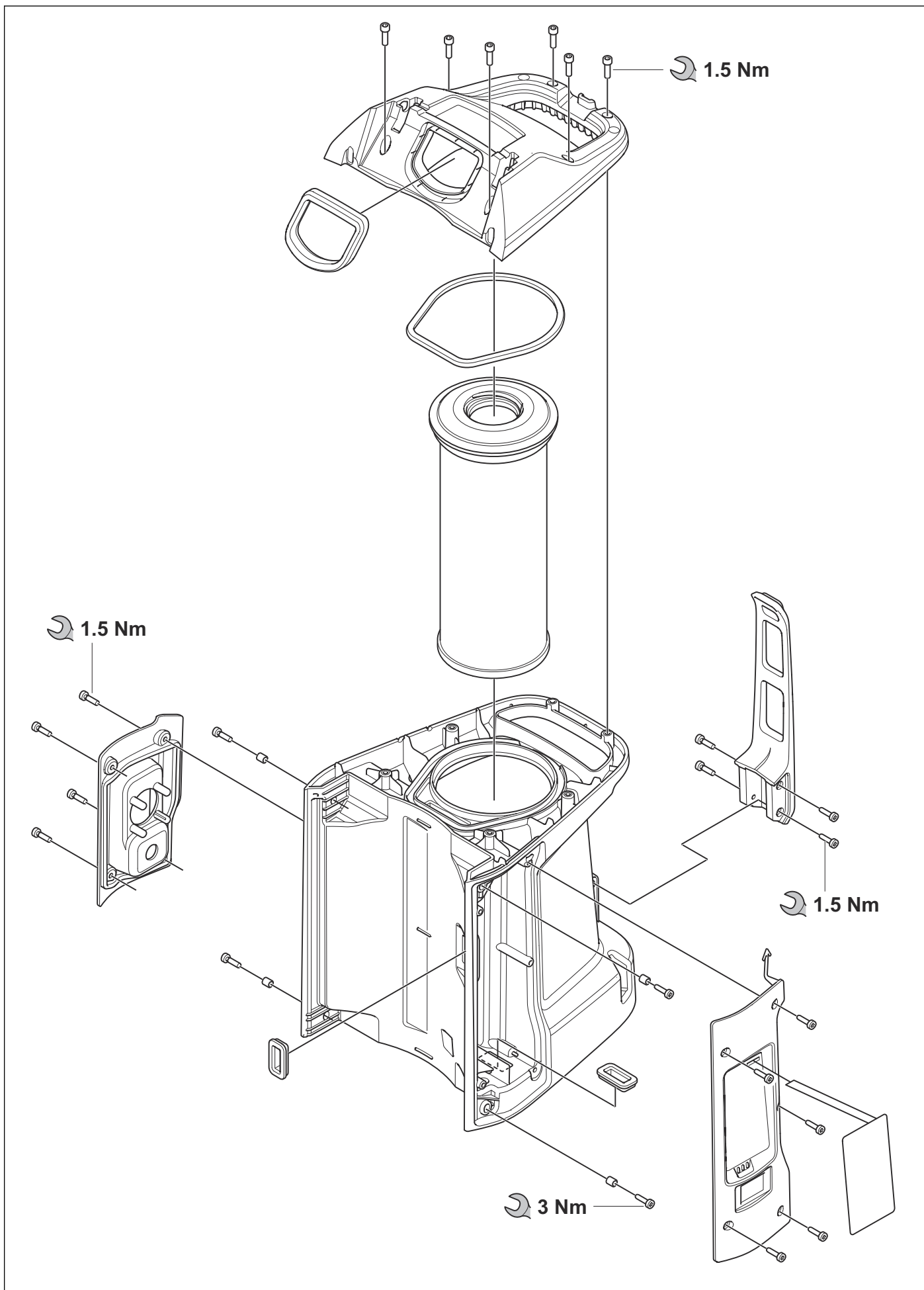

4.3 HEPA filter

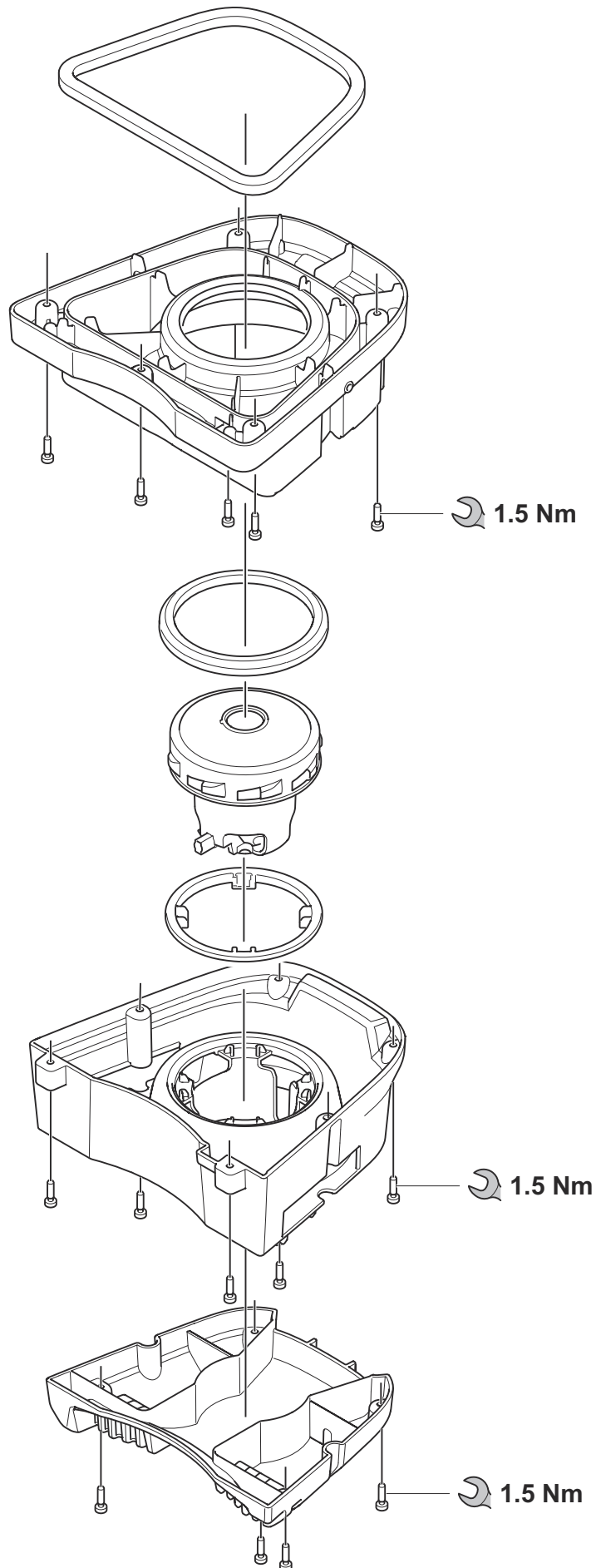

4.4 Chassis and wheels

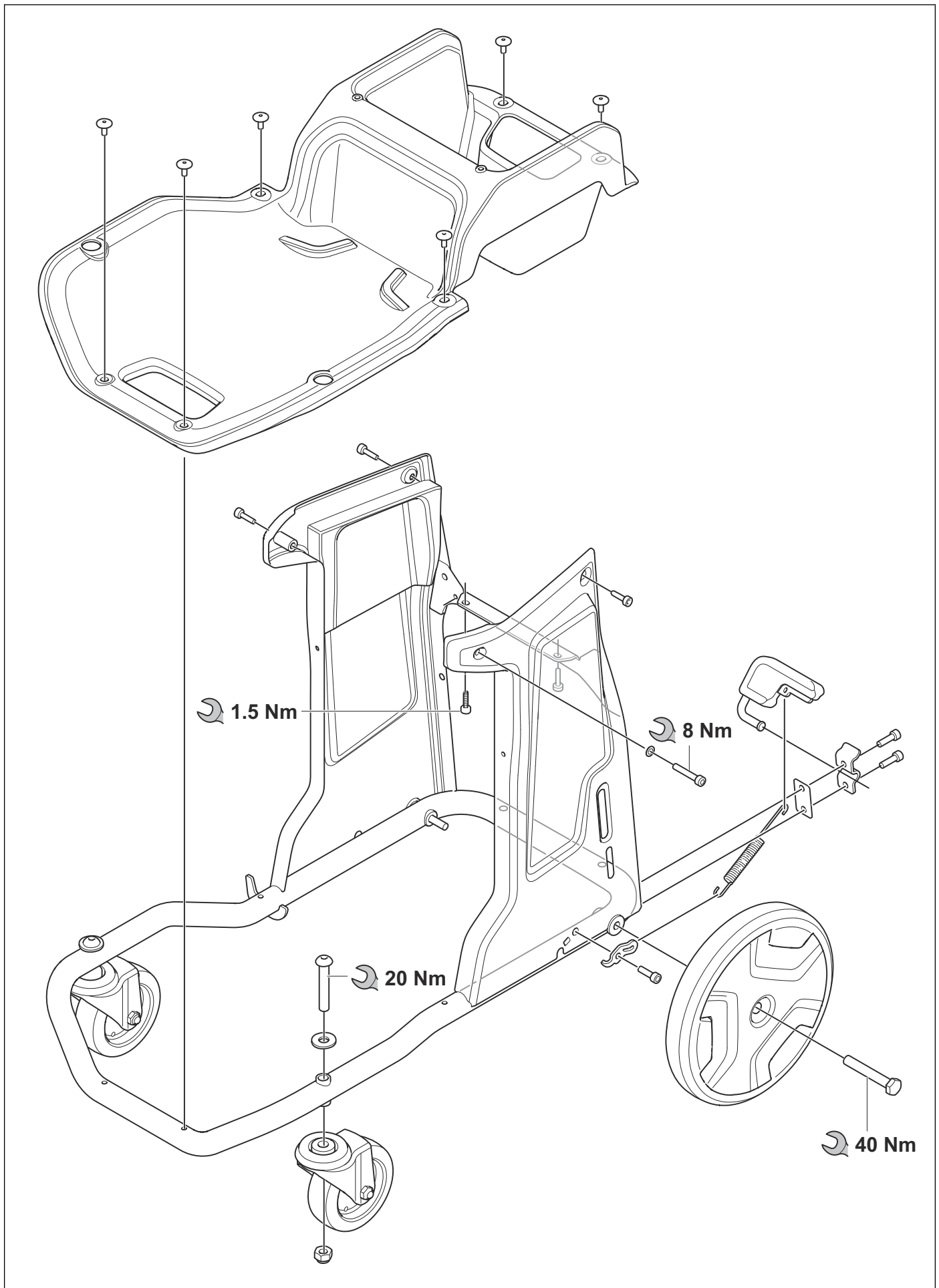

4.5 Prefilter container

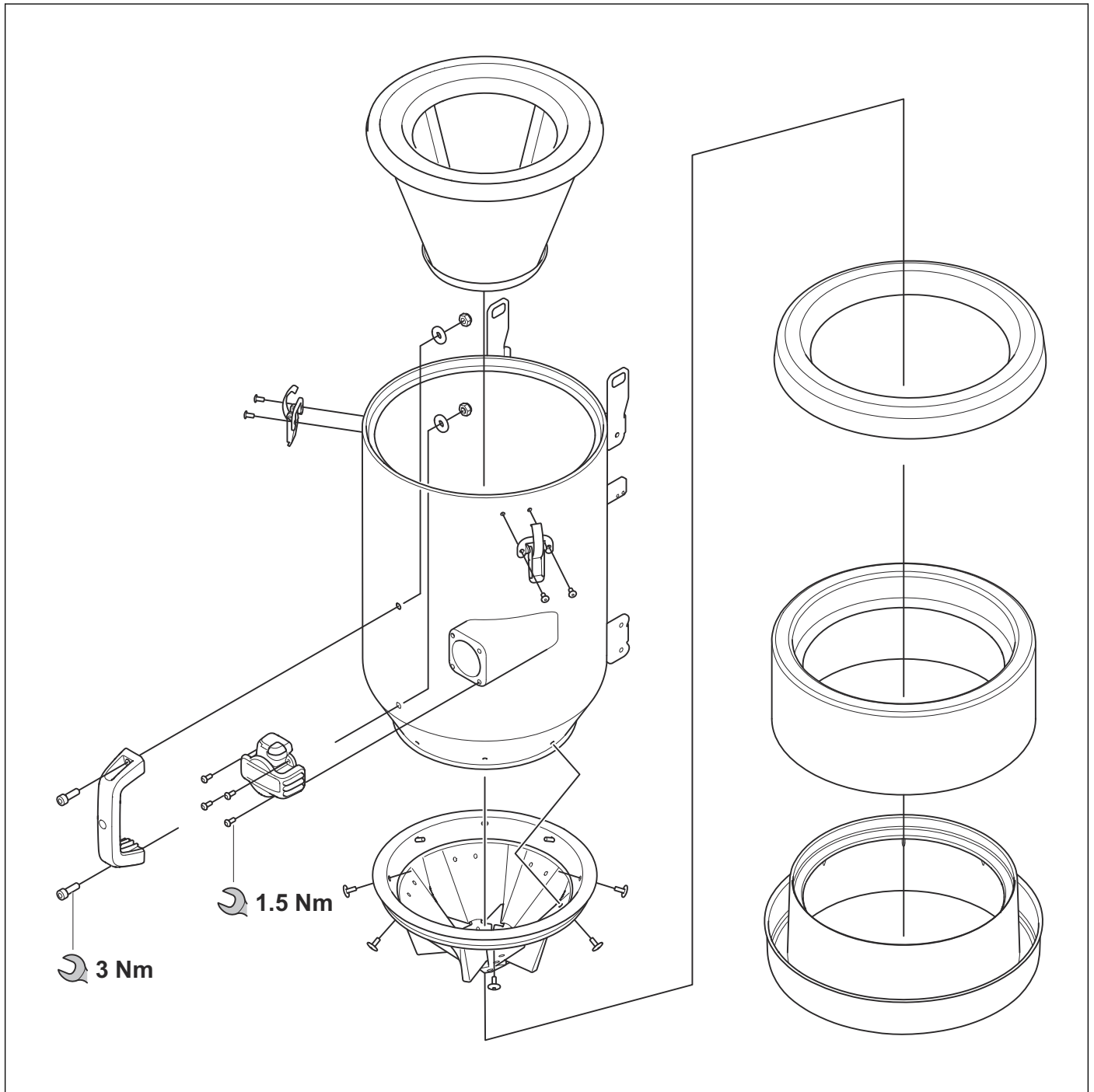

5 Function overview

5.1 Type plate and product serial number

The product serial number is on the type plate. Supply the model name and the article number when you send an order for spare parts.

5.2 Type plate

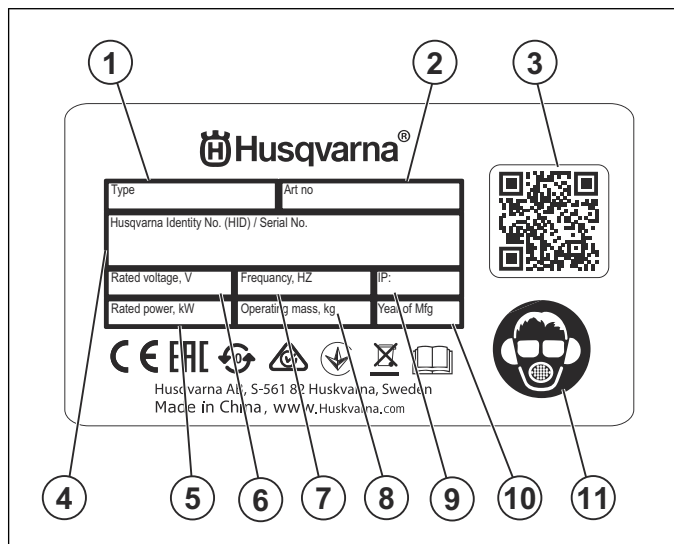

1. Model
2. Article number
3. Scannable code
4. Serial number
5. Rated power
6. Rated voltage
7. Frequency
8. Weight
9. IP class
10. Production year
11. Personal protective equipment

6 Product overview for repair and servicing

6.1 Product overview

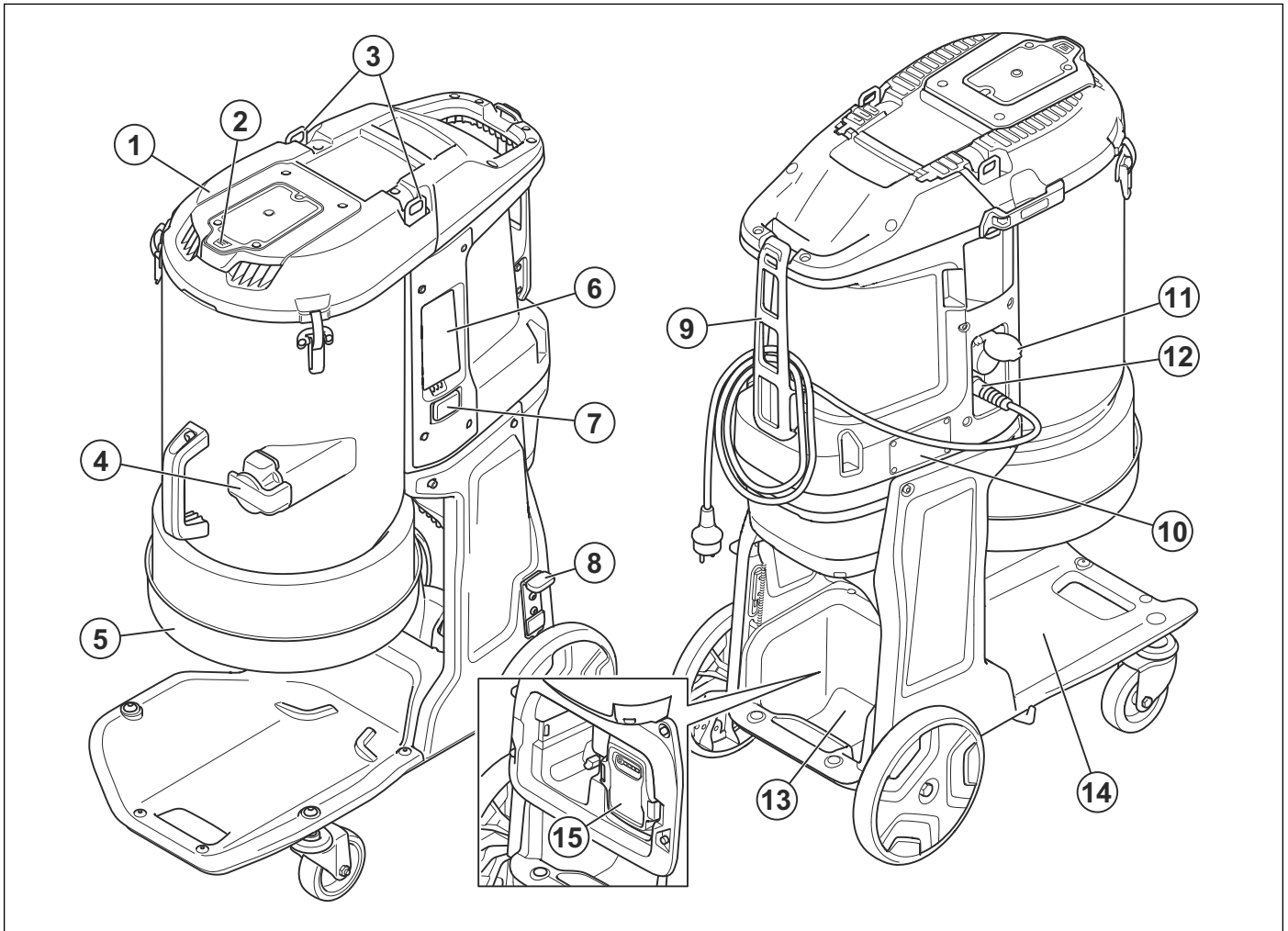

1. Prefilter cover
2. Filter cleaning button
3. Lifting eyes
4. Inlet cap
5. Longopac holder
6. Control panel
7. Hour meter
8. Wheel brake
9. Fastener for dust extraction hose
10. Type plate
11. Power outlet (only selected models)
12. Power cord
13. Battery compartment (Battery version)
14. Plate
15. Battery

7 Firmware

7.1 To do an update of the main circuit board

1. Stop the power.
2. Refer to *To connect the Husqvarna Service Hub on page 27.*

8 Repair and servicing

8.1 To clean and examine the product parts

- Clean and examine all parts fully. You find more instructions in the chapter for each part if special tools or procedures are necessary.
- Replace damaged parts.
- Always use original spare parts.

8.2 Prefilter

8.2.1 To remove and install the prefilter cover

1. Loosen the 2 clamps and open the prefilter cover.

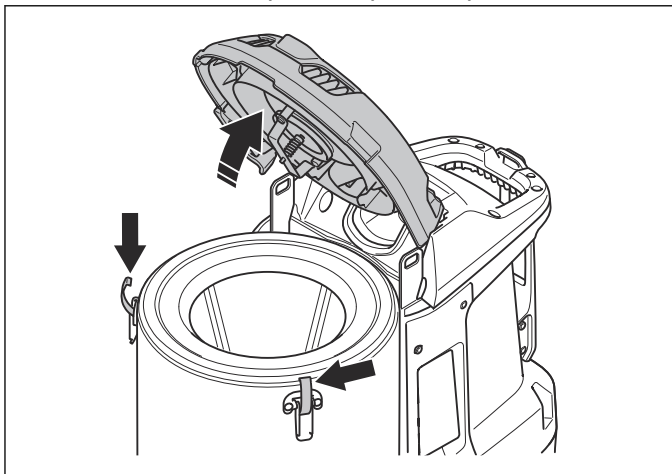

2. Remove the prefilter cover. If it is necessary, carefully use a screwdriver to remove the prefilter cover.

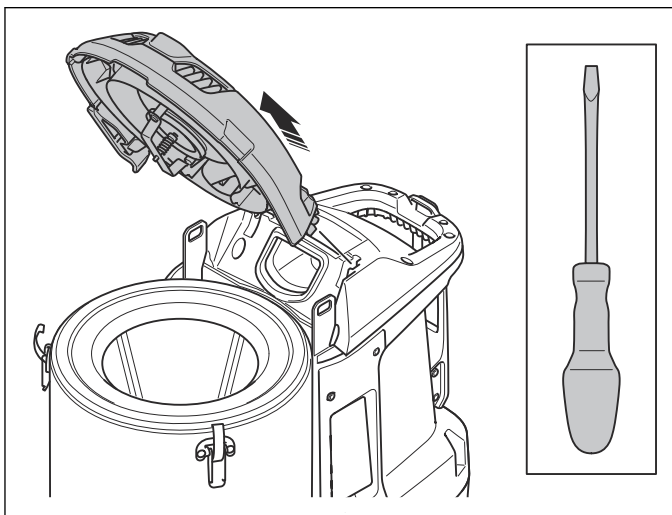

3. Install the prefilter cover in the opposite sequence.

8.2.2 To disassemble and assemble the prefilter cover

1. Remove the prefilter cover from the product. Refer to *To remove and install the prefilter cover on page 16*.
2. Remove the lid and spring lever for the pressure release valve.

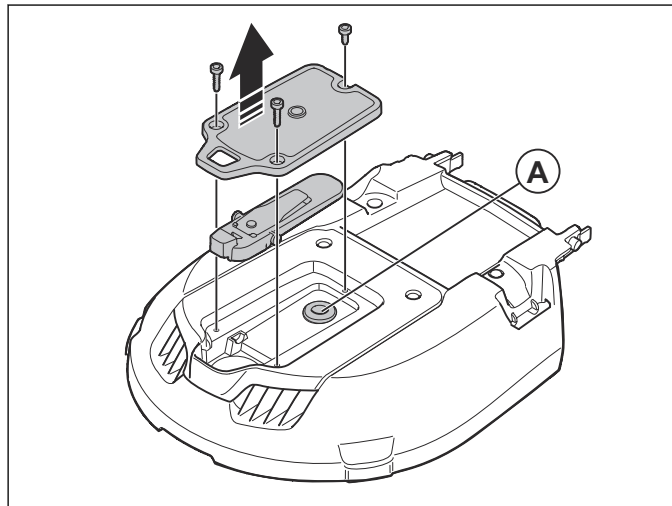

3. Make sure that the seal (A) is not damaged. If it is necessary, replace the seal.
4. Remove the bracket and the spring.

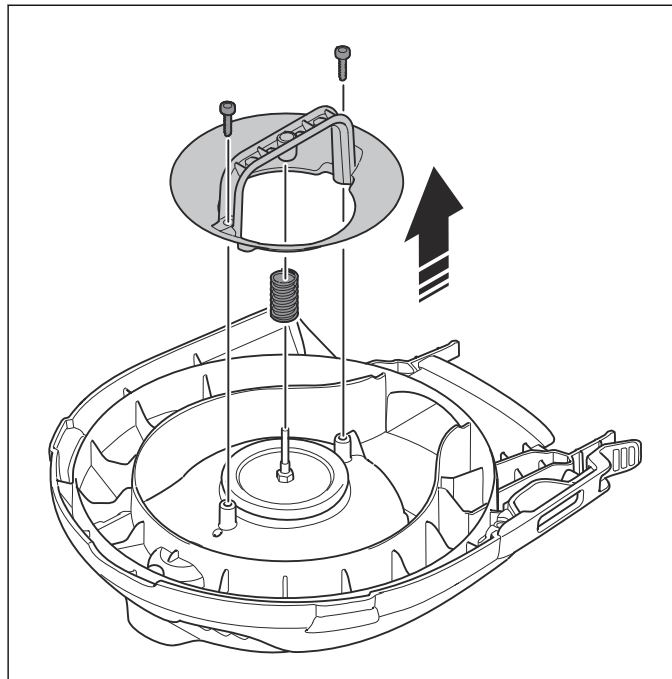

5. Remove the nut and the pressure release valve.

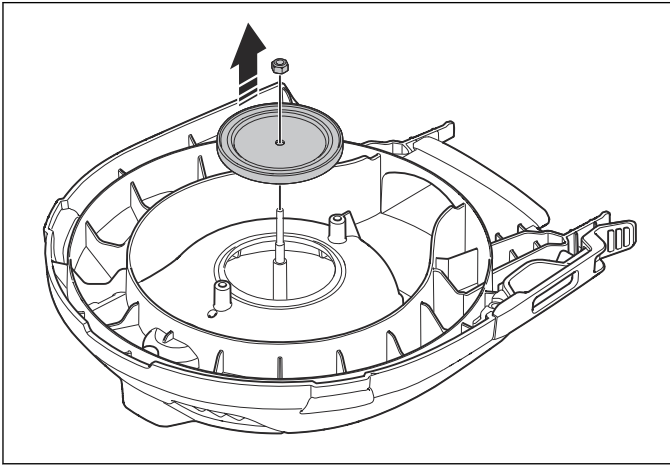

6. Remove the filter cleaning cover. Examine the seal for damage or wear.

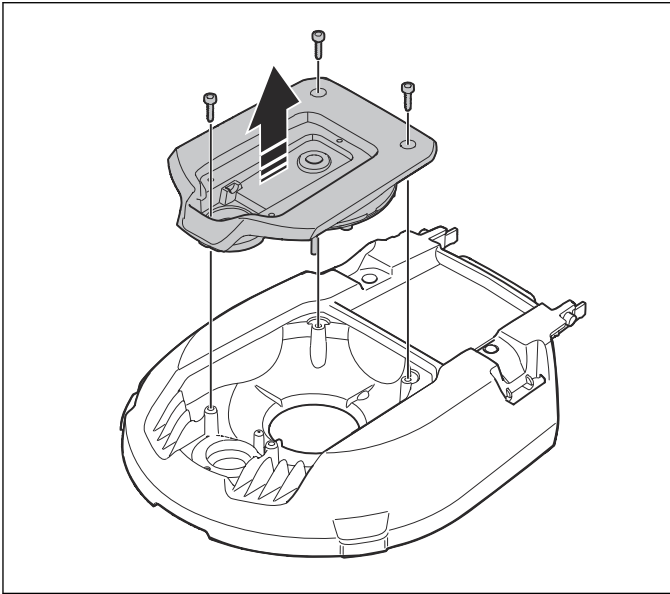

7. Assemble the prefilter cover in the opposite sequence.

8.3 HEPA filter

8.3.1 To remove and install the HEPA filter gasket



WARNING: Use approved eye protection and respiratory protection when you do servicing on the HEPA filter.

1. Remove the prefilter cover. Refer to *To remove and install the prefilter cover on page 16*.
2. Remove the screws and remove the HEPA filter cover.

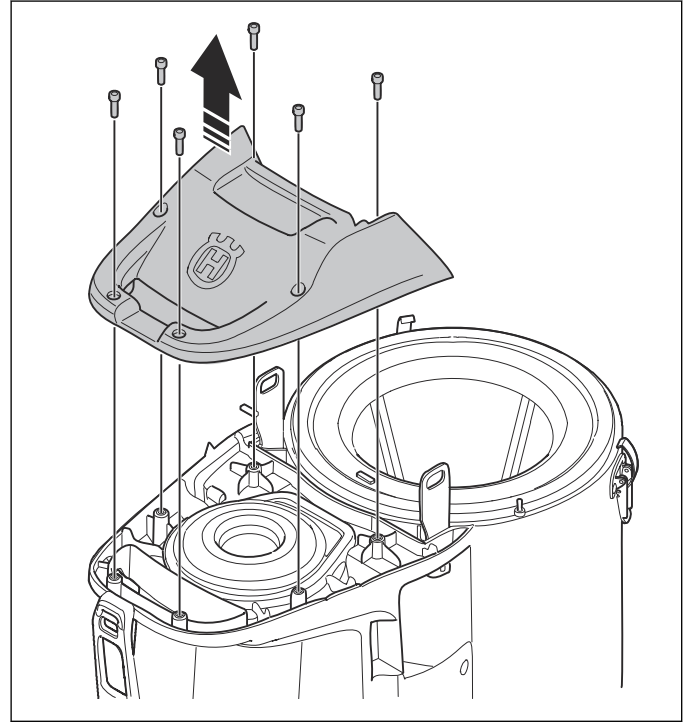

3. Attach the dust cap (A) and remove the HEPA filter (B).

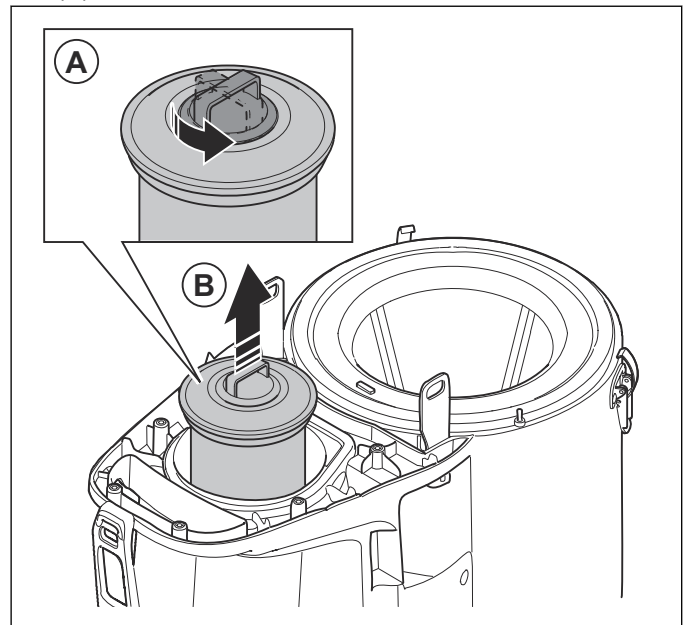

4. Carefully lift the HEPA filter into the plastic bag that came with the new HEPA filter.

5. Examine the gasket for wear or damage. If it is necessary, replace the gasket.

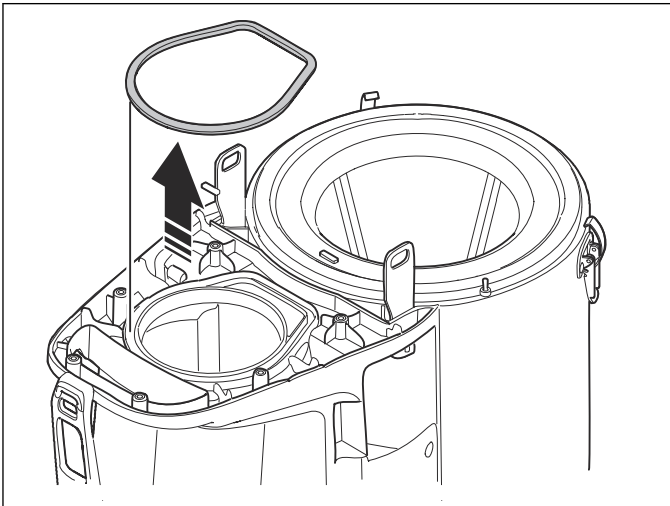

6. Examine the assembly for the HEPA filter for damage.

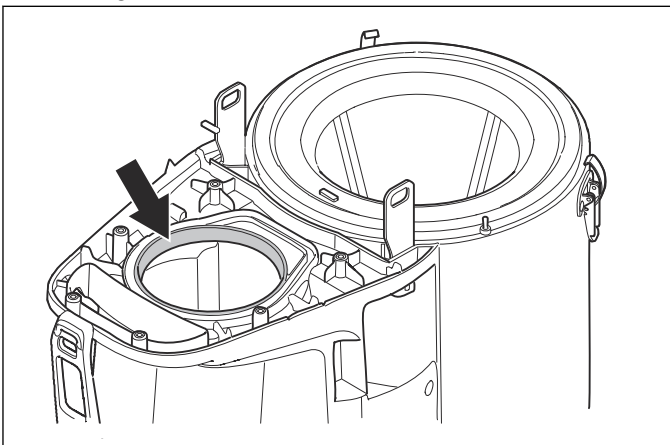

7. Install in opposite sequence.

8.4 Power cord

8.4.1 To remove and install the power cord



WARNING: Disconnect the power plug before you remove the power cord.

1. Remove the screws and the control panel lid.

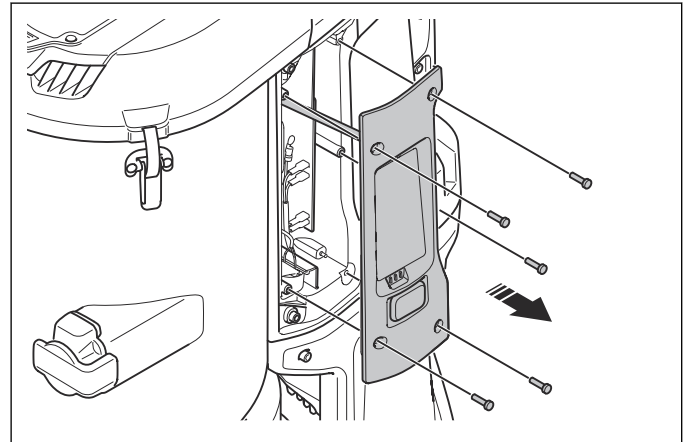

2. Disconnect the power cord connectors from the circuit board. Refer to *Diagrams on page 30*.

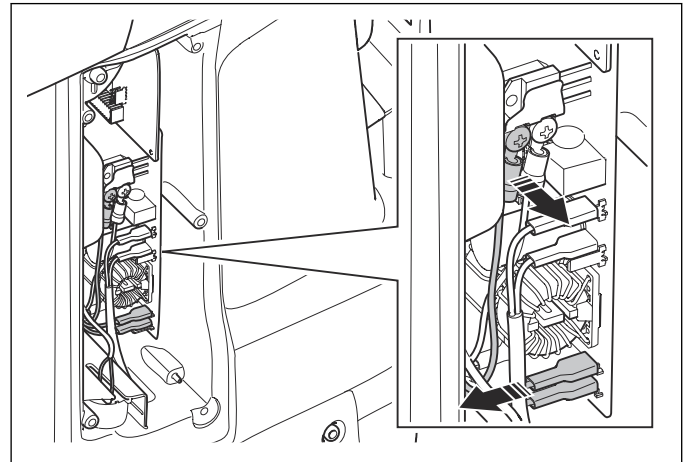

3. Remove the screws and the lid for the power cord.

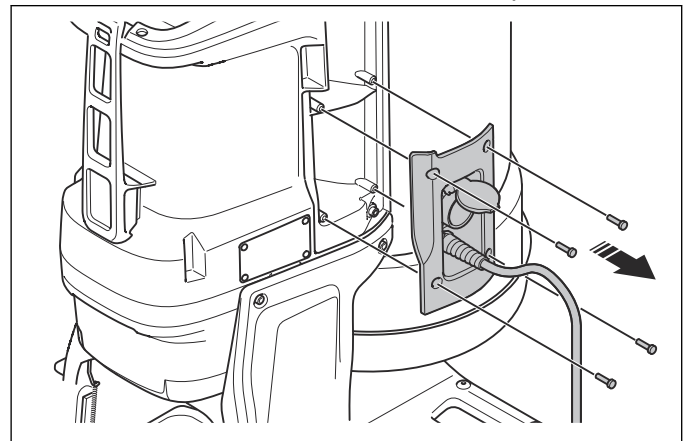

4. Remove the screws and the cables.

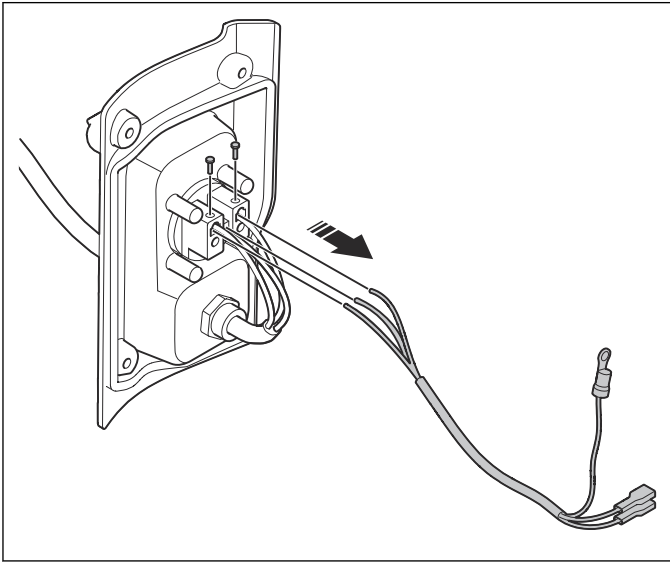

5. Install the power cord in the opposite sequence.
6. Do an electrical safety test. Obey local regulations.

8.4.2 To remove and install the power cord DE 110i H, DE 120 H PACE



WARNING: Disconnect the battery before you remove the power cord.

1. Remove the screws and the control panel lid.

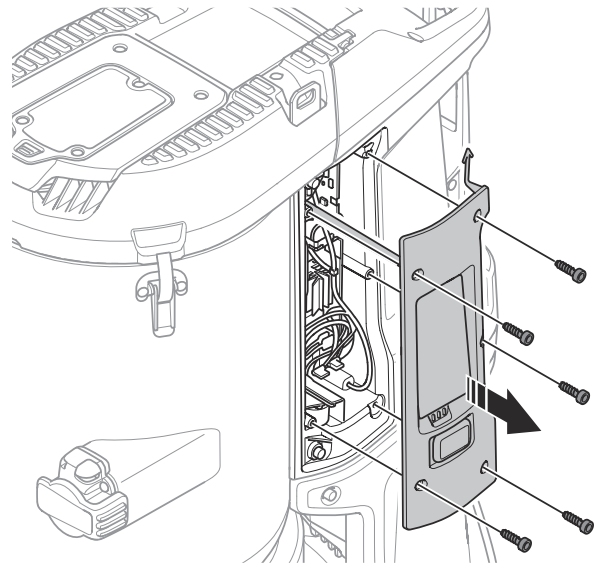

2. Disconnect the power cord connectors from the circuit board. Refer to *Diagrams on page 30*.

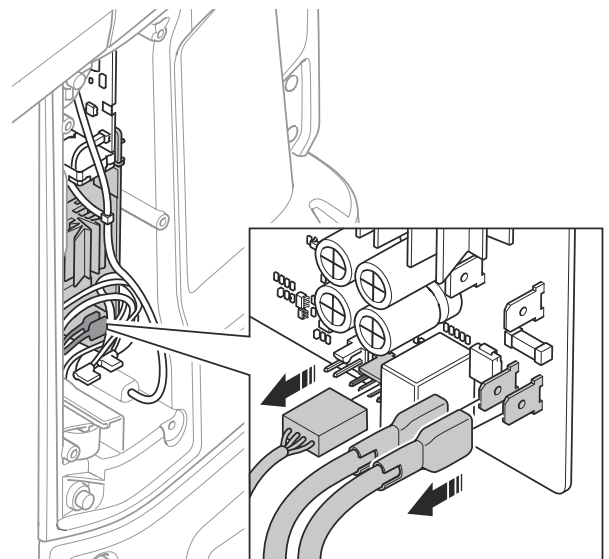

3. Remove the screws and pull out the battery compartment.

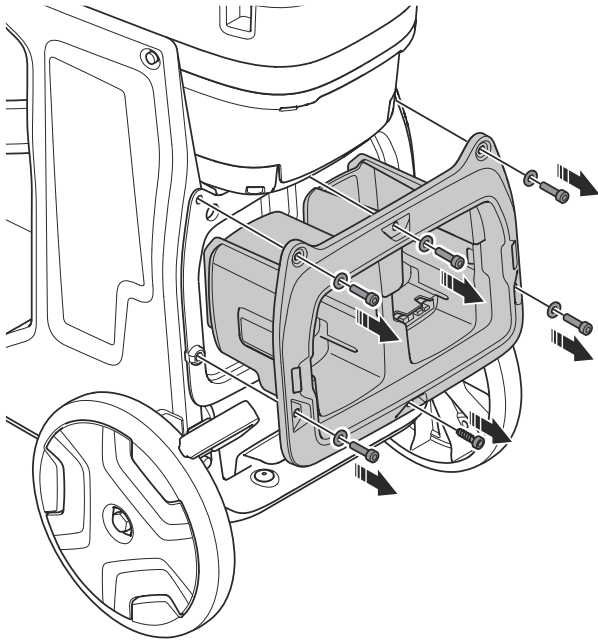

4. Remove the screws and the cables.

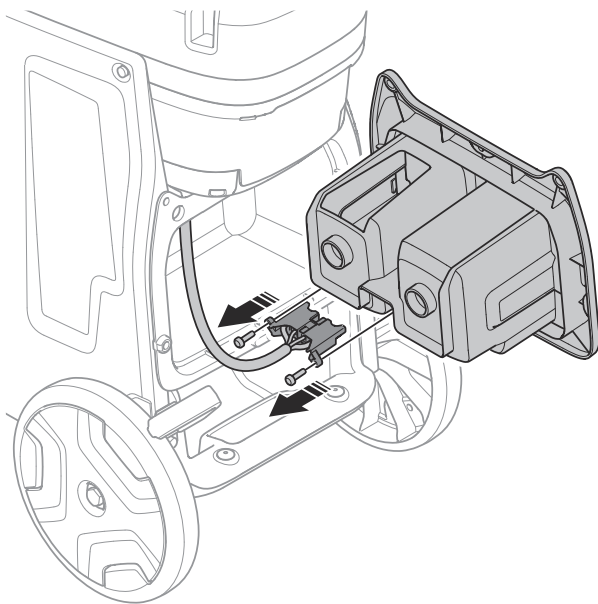

5. Install the power cord in the opposite sequence.
6. Do an electrical safety test. Obey local regulations.

8.5 Circuit board

8.5.1 To remove the circuit board



CAUTION: Always use ESD wristbands. Make sure that workbenches and storage areas for used components have ESD protection.



CAUTION: The circuit board and the air connectors are easily damaged. The air hoses must be removed carefully.

1. Remove the screws and the control panel lid.

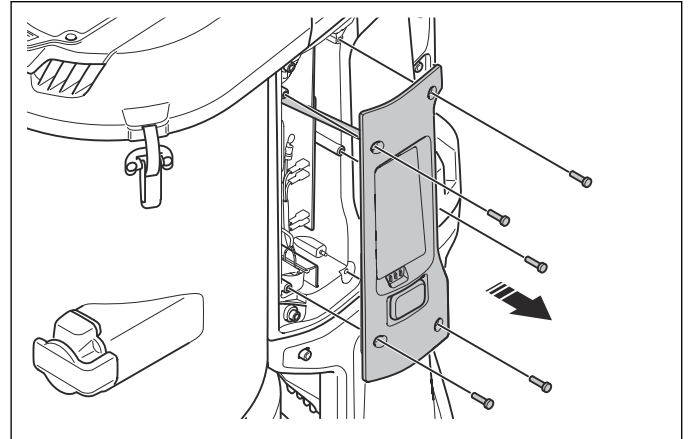

2. Disconnect the electrical connectors from the circuit board. Refer to *Diagrams on page 30*.
3. Disconnect the them from the circuit board.

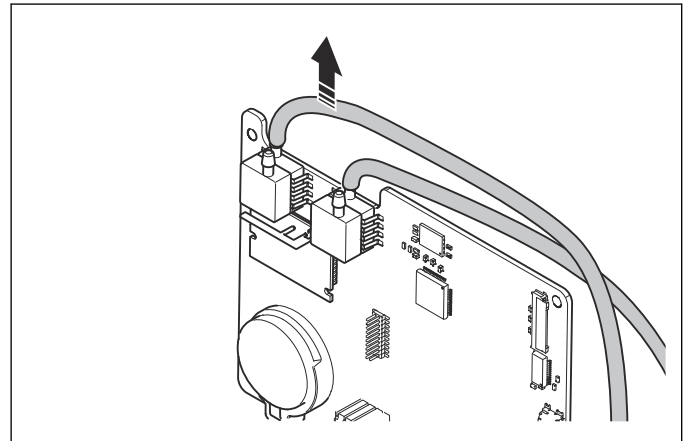

8.5.2 To install the circuit board



CAUTION: Always use ESD wristbands. Make sure that workbenches and storage areas for used components have ESD protection.



CAUTION: The circuit board and the air connections are easily damaged. The air hoses must be installed carefully.

1. Connect the electrical connectors to the circuit board. Refer to *Diagrams on page 30*.
2. Install the circuit board.

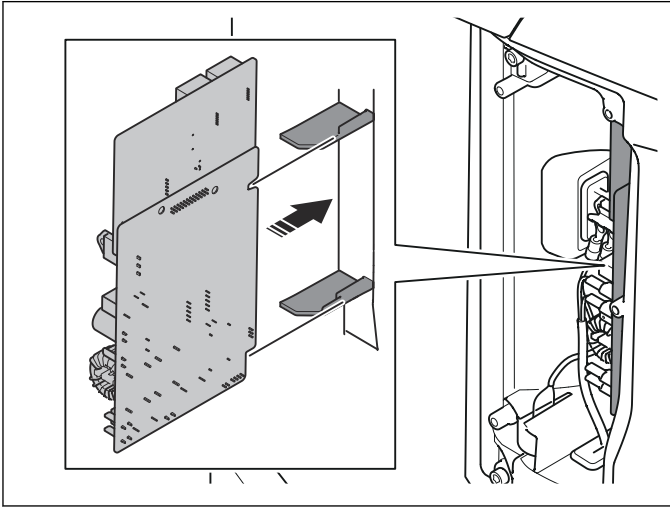

3. Do an update of the firmware in the product. Refer to *To do an update of the main circuit board on page 15*.
4. Install the control panel lid.

8.6 Chassis

8.6.1 To remove and install the chassis

1. Empty the Longopac.
2. Put the product with the top side down.

3. Remove the screws.

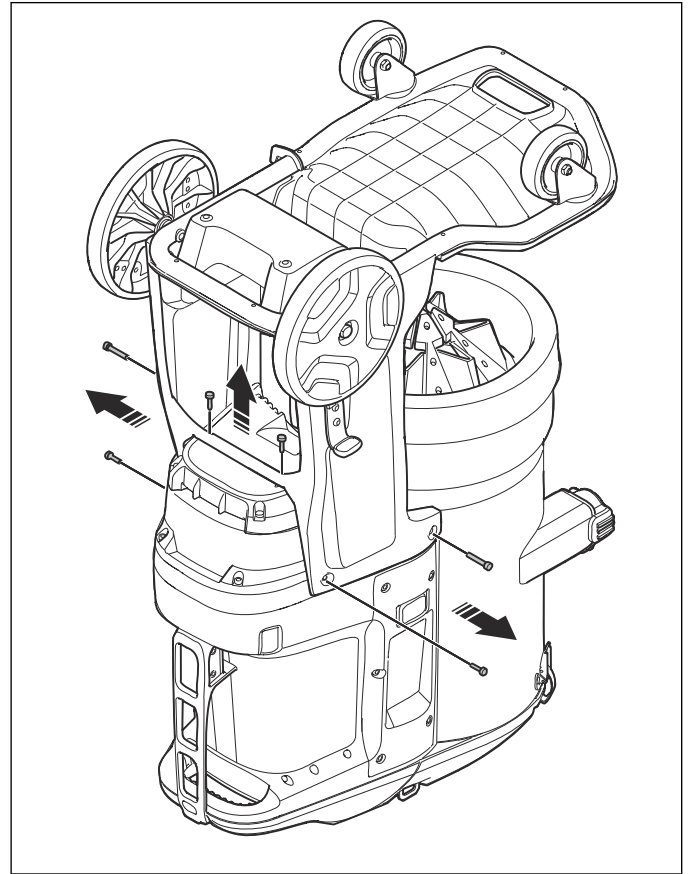

4. Remove the chassis.

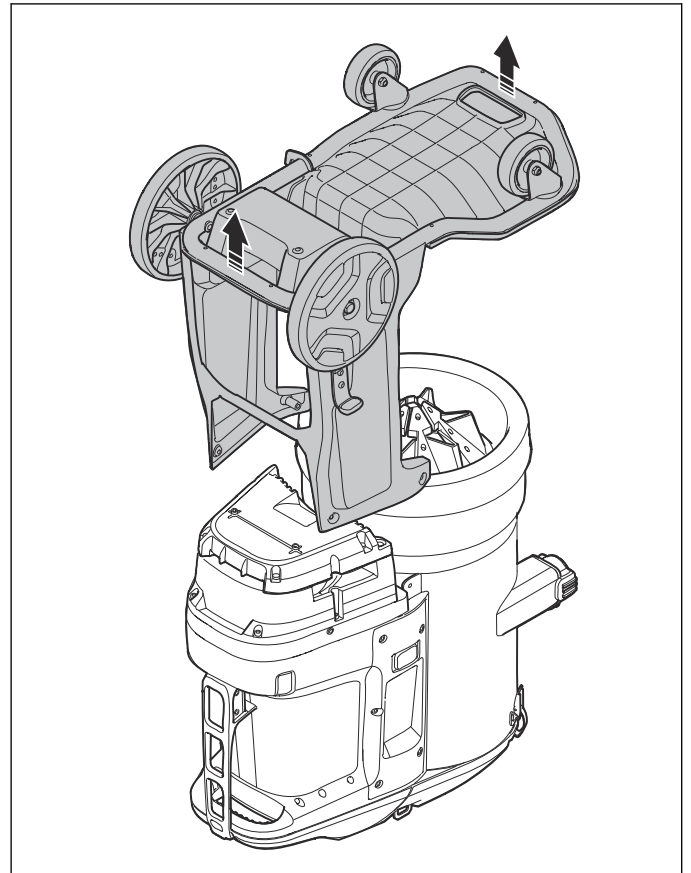

5. Install the chassis in the opposite sequence.

8.6.2 To remove and install the plate

1. Remove the wheels.

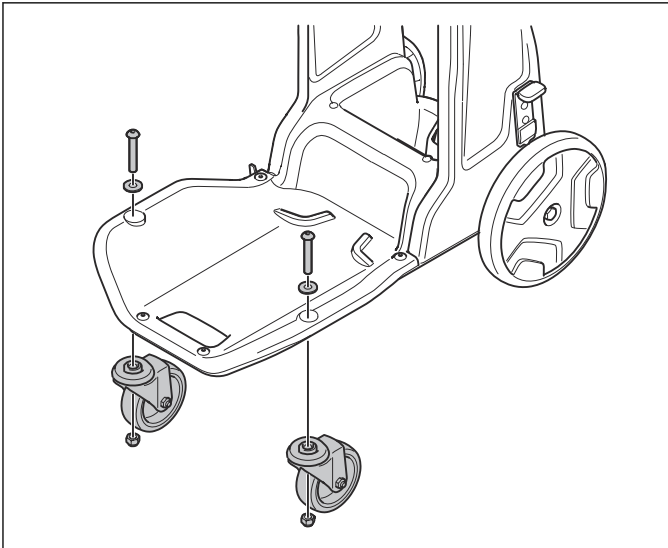

2. Remove the rivets. Use a 4.5 mm drill bit.

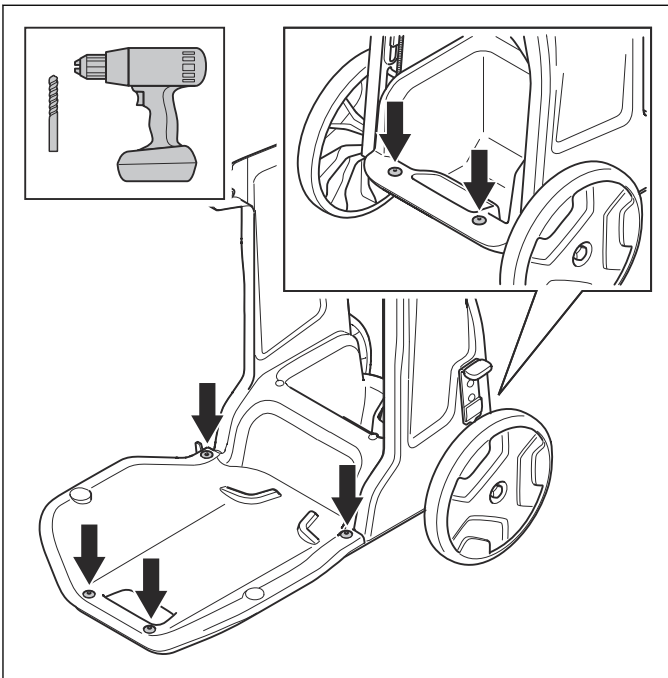

3. Remove the plate.

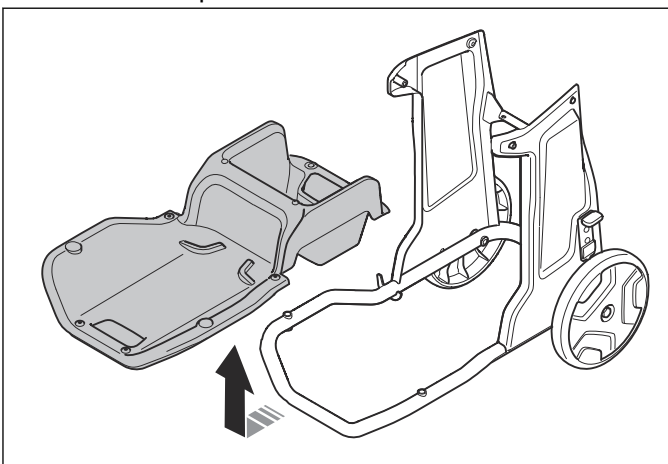

4. Install the plate in the opposite sequence.

8.7 Container

8.7.1 To remove and install the prefilter container

1. Remove the prefilter cover. Refer to *To remove and install the prefilter cover on page 16*.
2. Remove the screws and the control panel lid.

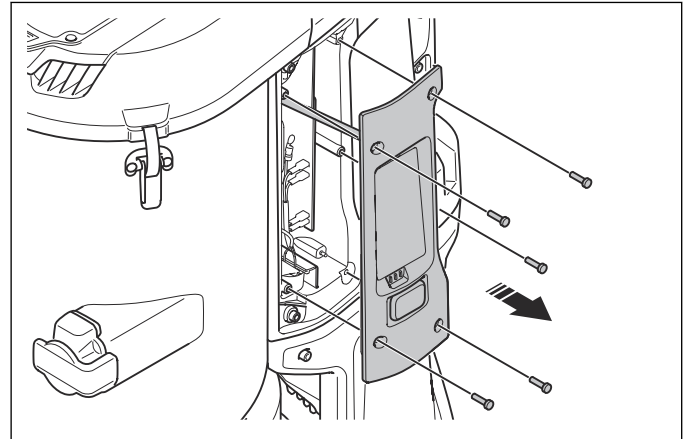

3. Remove the ground wires.

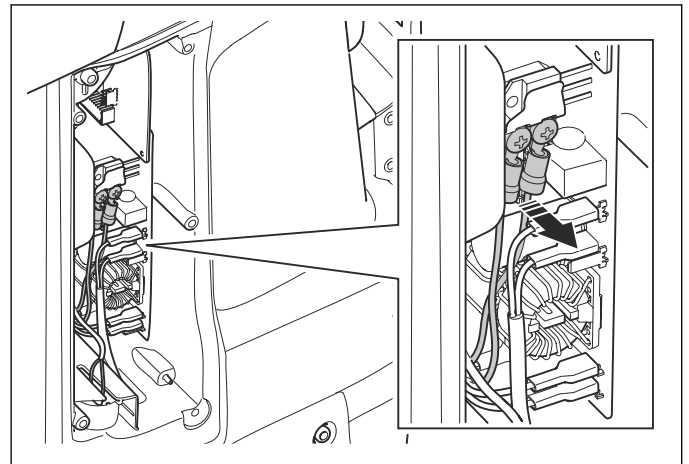

4. Remove the screws and the lid for the power cord.

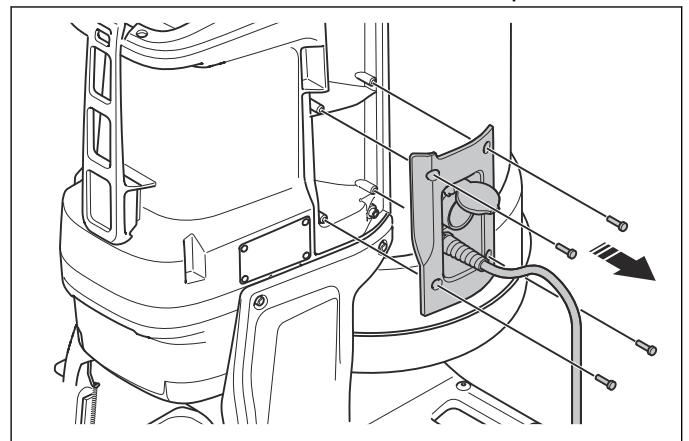

5. Remove the screws on each side of the frame.

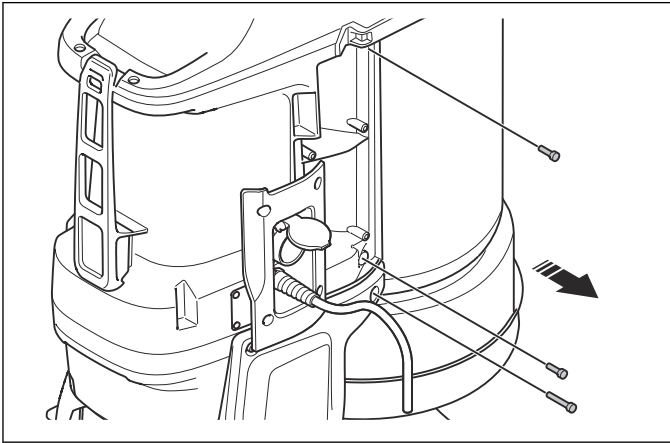

6. Remove the prefilter container.

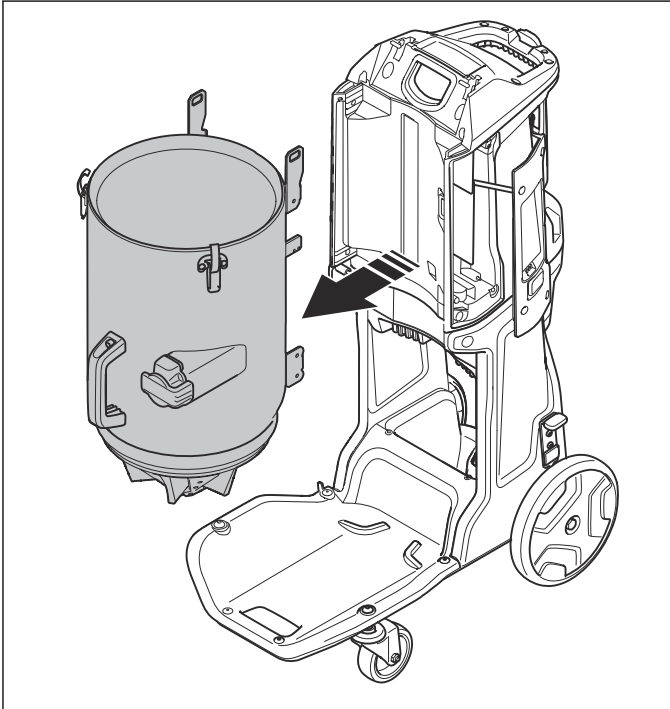

7. Install the prefilter container in the opposite sequence.

8.7.2 To remove and install the Longopac gasket

1. Remove the rivets with a drill.

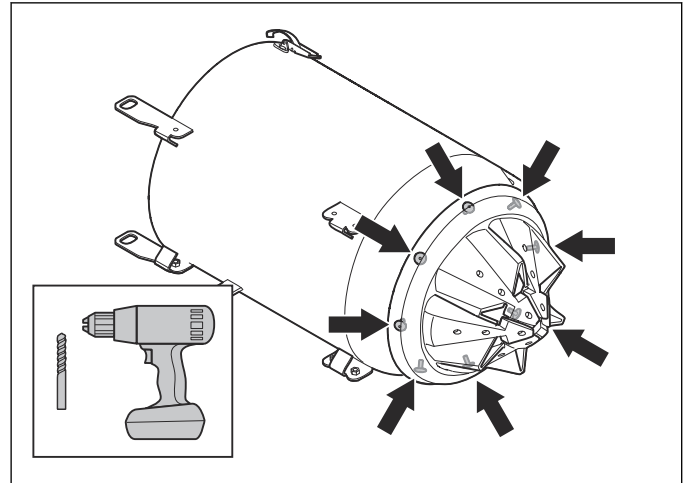

2. Remove the Longopac gasket.

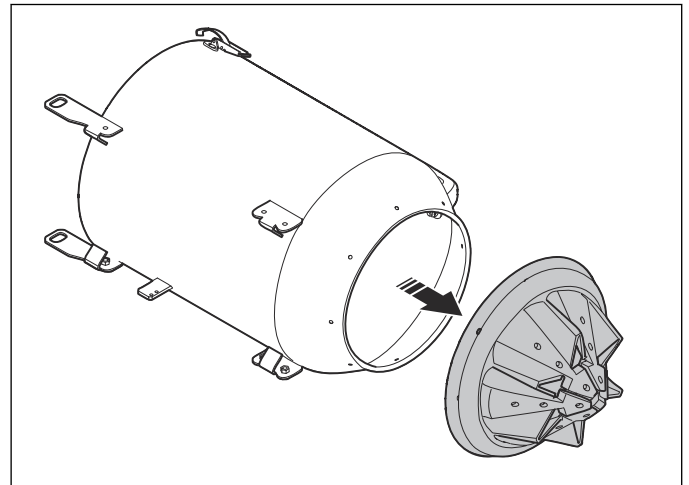

3. Install the Longopac gasket in the opposite sequence.

8.8 Battery

8.8.1 To remove and install the battery (battery version)

1. Push the button (A) to release the battery (B) from the battery compartment.

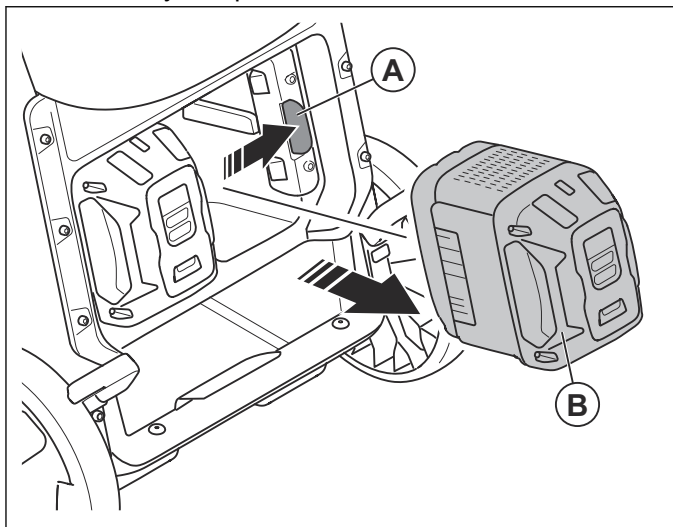

2. Push the battery into the battery compartment to install the battery.

8.9 Motor

8.9.1 To disassemble and assemble the motor housing

1. Remove the frame. Refer to *To remove and install the chassis on page 21*.
2. Remove the cover.

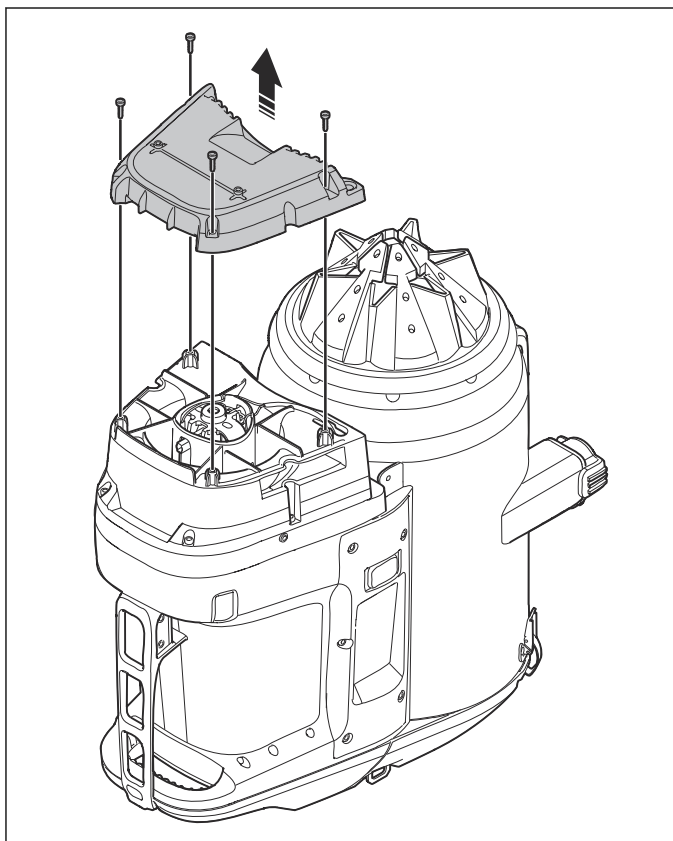

3. Cut the straps and disconnect the wires to the motor.

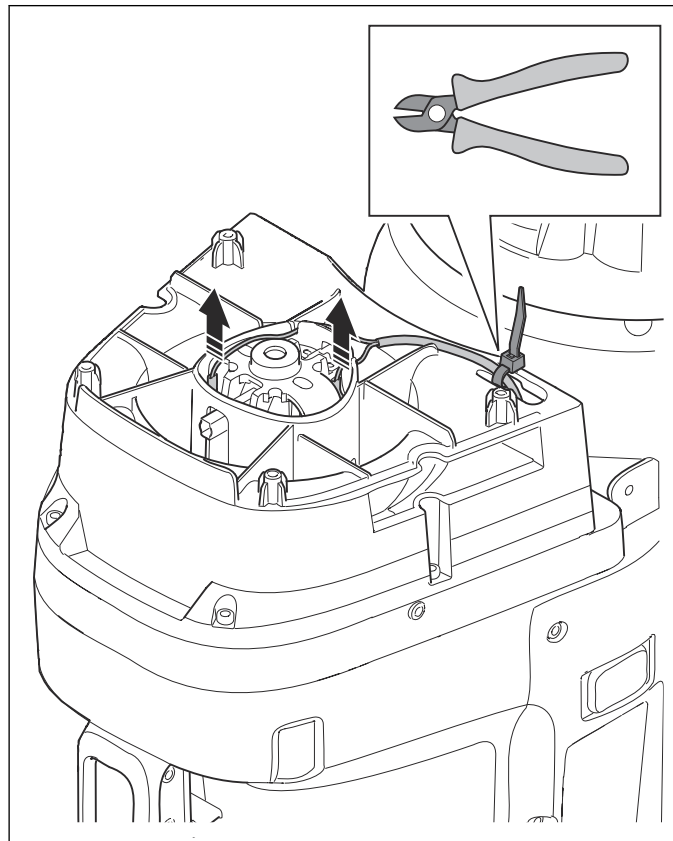

4. Remove the screws and the motor cover.

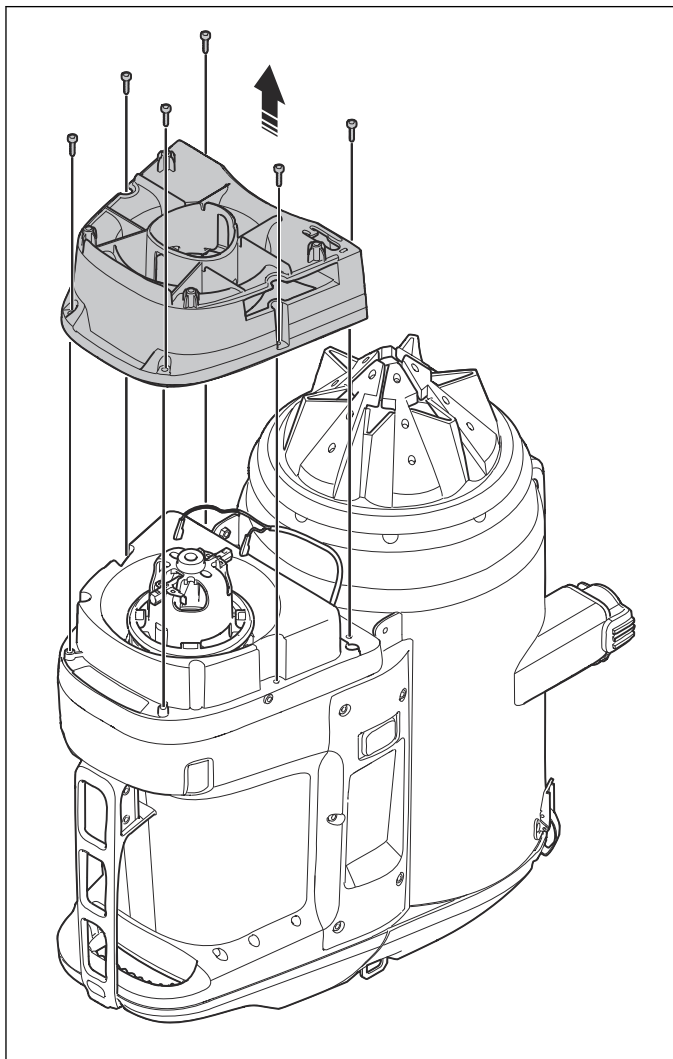

6. Remove the screws and the motor holder.

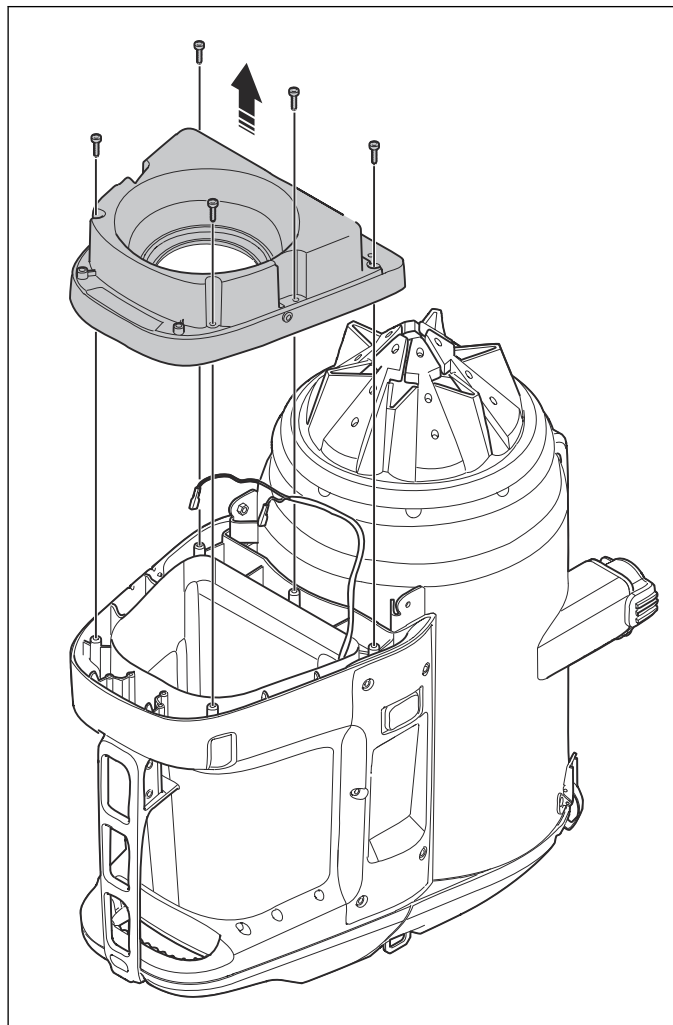

5. Remove the motor.

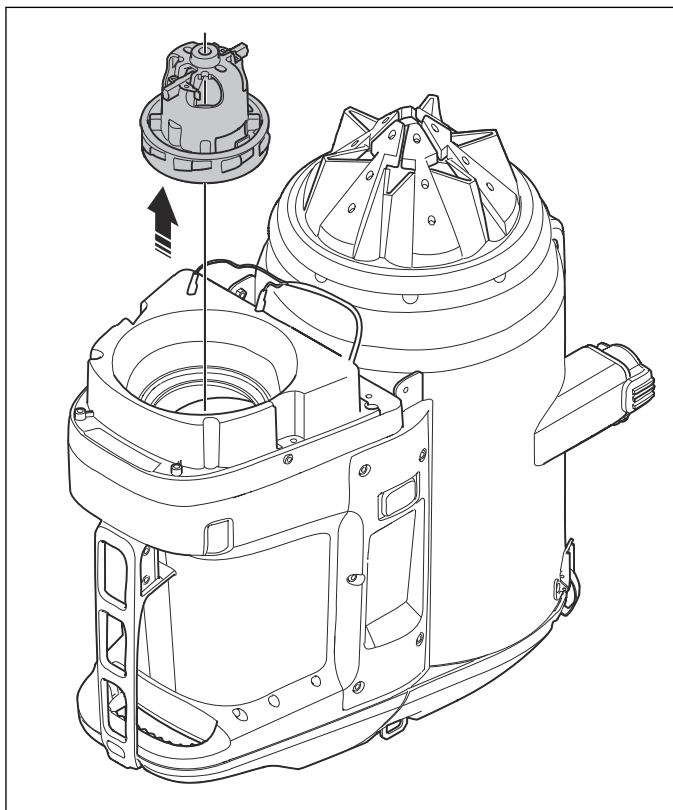

7. Remove the gaskets from the motor holder. Make sure that the gaskets are not damaged.

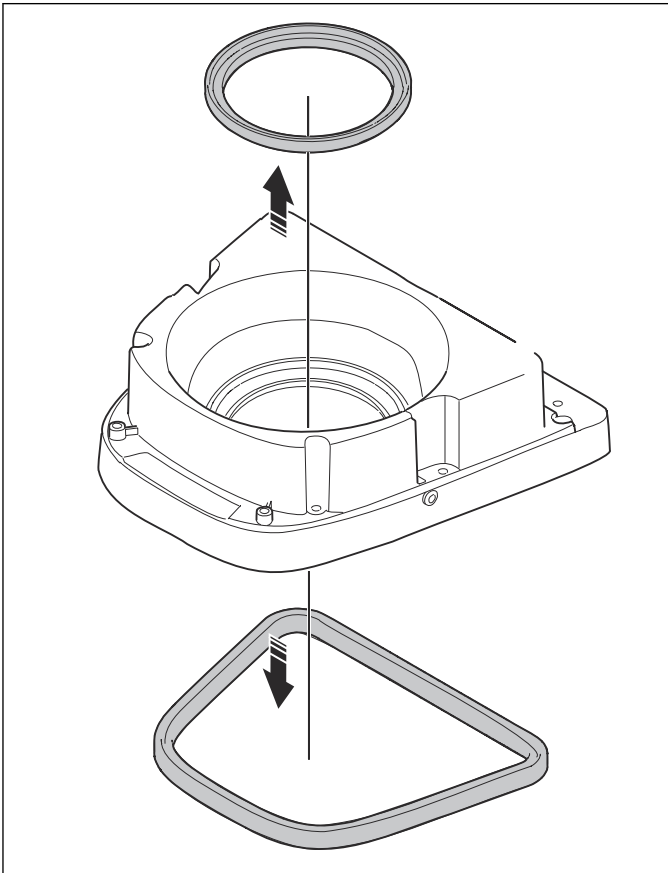

8. Assemble the motor housing in the opposite sequence.

8.9.2 To replace the brushes on the motor

1. Remove the motor. Refer to *To disassemble and assemble the motor housing on page 24*.
2. Remove the screws and the brush holders.

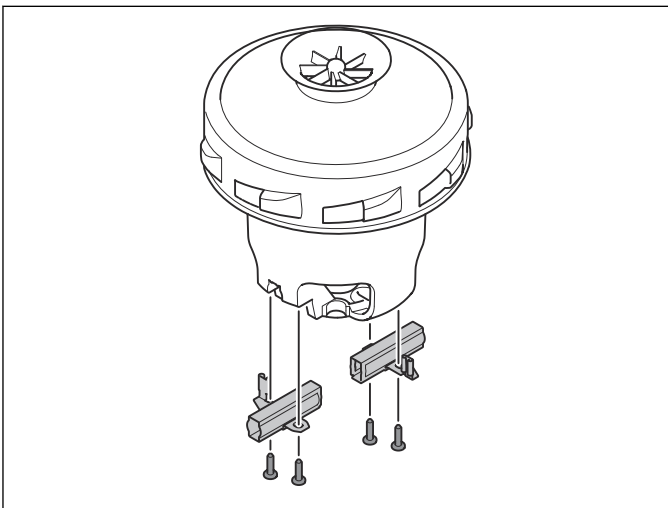

3. Install the new brush holders in the opposite sequence.
4. Assemble the motor housing in the opposite sequence. Refer to *To disassemble and assemble the motor housing on page 24*.

9 Troubleshooting

9.1 To connect the Husqvarna Service Hub

1. Open the lid to the control panel and find the USB connection.

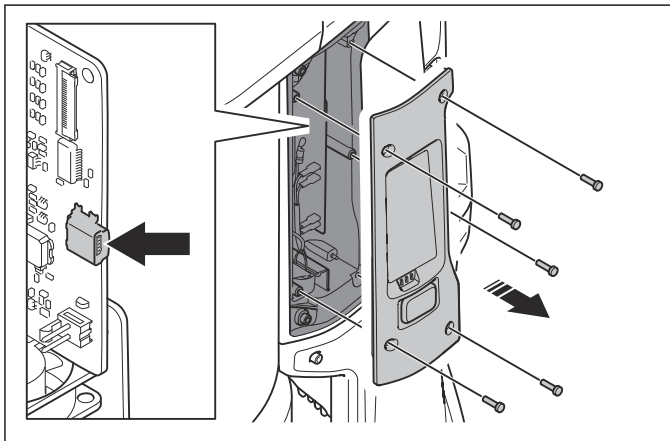

2. Connect the USB cable for the Husqvarna Service Hub to the control panel.
3. Start the product to do a software update.

Note: Refer to the manual of the Husqvarna Service Hub for instructions and obey the instructions.

9.2 To do troubleshooting of Husqvarna Service Hub (HSH)

If there is no signal to Husqvarna Service Hub (HSH) when it is connected to the product, do the procedure that follows.





1. Make sure that the connectors on HSH Interface Box and on the product are clean and not damaged. Replace all damaged parts.
2. Make sure that the cables connected to the computer, HSH Interface Box and the product are clean and not damaged. Replace all damaged cables.
3. Restart the computer.
4. Install the software again.

9.3 Troubleshooting schedule

Problem	Cause	Solution
The motor stops immediately after start or does not start.	There is no power.	Connect the product to a power supply.
	The power cord is defective.	Send the product to a Husqvarna service center.
	There is a short circuit in the product.	Send the product to a Husqvarna service center.
	The HEPA filter is damaged or not installed (DE 110 SH/DE 120 H).	Replace or install the HEPA filter.
	Too high voltage in power supply.	Make sure that correct power supply is used.
	Too high ambient temperature.	Make sure that the ambient temperature is in specified range when you use the product.
	Fan is broken or disconnected.	Send the product to a Husqvarna service center.
The motor is on but there is no suction.	The dust extraction hose is not connected correctly.	Connect the dust extraction hose.
	The dust extraction hose is blocked.	Clean the dust extraction hose.
	There is no Longopac bag.	Install a Longopac cassette.
	The Longopac is not closed down with a cable tie.	Attach a cable tie.
The suction is not sufficient.	Too low voltage in power supply.	Make sure that correct power supply is used.
	There is a hole in the dust extraction hose.	Replace the dust extraction hose.
	The prefilter is clogged.	Remove dust particles from the prefilter. Clean or replace it if it is necessary.
	The HEPA filter is clogged.	Replace the HEPA filter. Refer to <i>To remove and install the HEPA filter gasket on page 17.</i>
	The top cover is loose.	Close the top cover fully.
	The seals are broken.	Replace the seals.

Problem	Cause	Solution
Dust releases into the air from the motor.	The filters are incorrectly installed or damaged.	Install the filters correctly. Replace damaged filters.
Unusual noise comes from the product.	N/A	Send the product to a Husqvarna service center.

9.4 Warnings on the control panel

Symbol	Signal	Cause	Solution
	Buzzer signal and the red light comes on.	The prefilter is clogged.	Do a filter purge procedure.
		Incorrect hose is connected or selected in the control panel.	Attach correct hose or select the correct hose dimension on control panel.
		The hose is damaged or compressed.	Replace the hose.
		The hose is clogged.	Clear the hose.
	The red light flashes.	The main vacuum hose is disconnected.	Send the product to a Husqvarna service center.
	Red light comes on.	The HEPA filter is missing, full or damaged.	Do a check of the HEPA filter, replace if it is necessary. Refer to <i>To remove and install the HEPA filter gasket on page 17.</i>
		The motor is damaged.	Do a check of the motor. Refer to <i>Motor on page 24.</i>
	Red light comes on.	The control unit is damaged.	Send the product to a Husqvarna service center.
		Too high ambient temperature.	Make sure that the ambient temperature is in specified range when you use the product.
		Warning.	Look at the operation record of your Husqvarna Fleet Services™ app or send the product to a Husqvarna service center.
	Yellow light comes on.	The HEPA filter is almost full.	Replace the HEPA filter if it is necessary.
	Red light comes on.	The HEPA filter is full.	Replace the HEPA filter.

9.5 Error codes

Error code	Error	Description	Probable cause(s)	Action(s)
2	HEPA filter missing.	Product shuts down/does not start. + Warning light on HMI. + HEPA symbol on HMI.	HEPA filter is missing or damaged.	Assemble or replace the HEPA filter.
3	Low supply voltage.	Low performance (low air flow/vacuum).	Too low voltage in grid/power supply.	Make sure correct grid/power supply is used.
4	High supply voltage.	Product shuts down/does not start. + Warning diode light on HMI.	Too high voltage in grid/power supply.	Make sure correct grid/power supply is used.
			Wrong battery used.	Use correct battery.
5	Main Pressure Sensor Error.	Pre-filter light flashes red.	Vacuum hose is disconnected or blocked.	Send the product to a Husqvarna service center.
			Control unit is damaged.	
6	PCBA temperature too high.	Product shuts down/ does not start. + Warning diode light on HMI.	Too high ambient temperature.	Do not use the product outside specified temperature range.
7	Fan malfunction.	Product shuts down/ does not start. + Warning diode light on HMI.	Fan is damaged or disconnected.	Send the product to a Husqvarna service center.
			Control unit is damaged.	
9	One wire communication not detected.	Product shuts down/ does not start. + Warning diode light on HMI.	Cable disconnected or damaged.	Send the product to a Husqvarna service center.

10.2 Wiring diagram DE 110 SH, EU/AUS

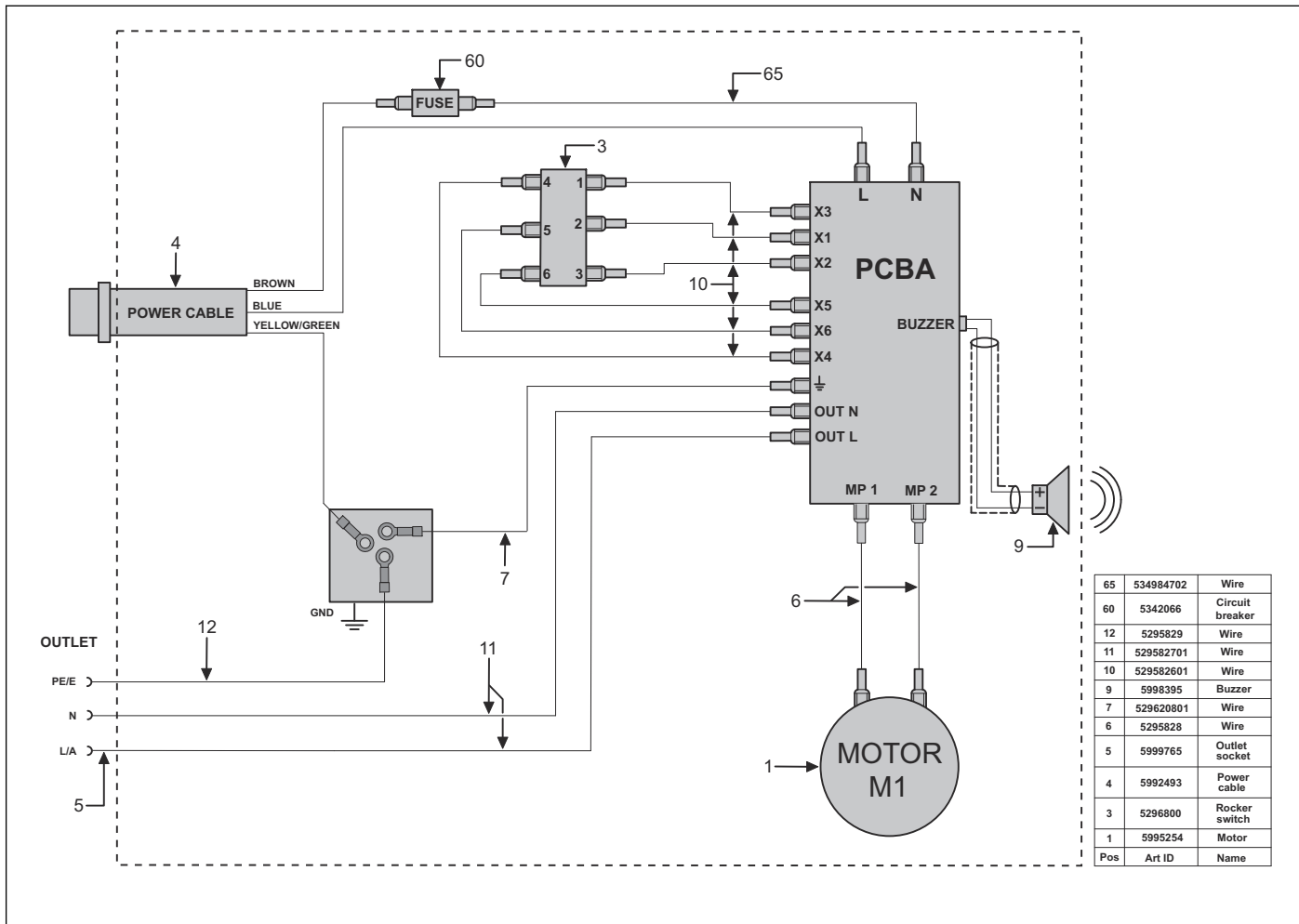

10.3 Wiring diagram DE 110 SH, US/UK/JPN

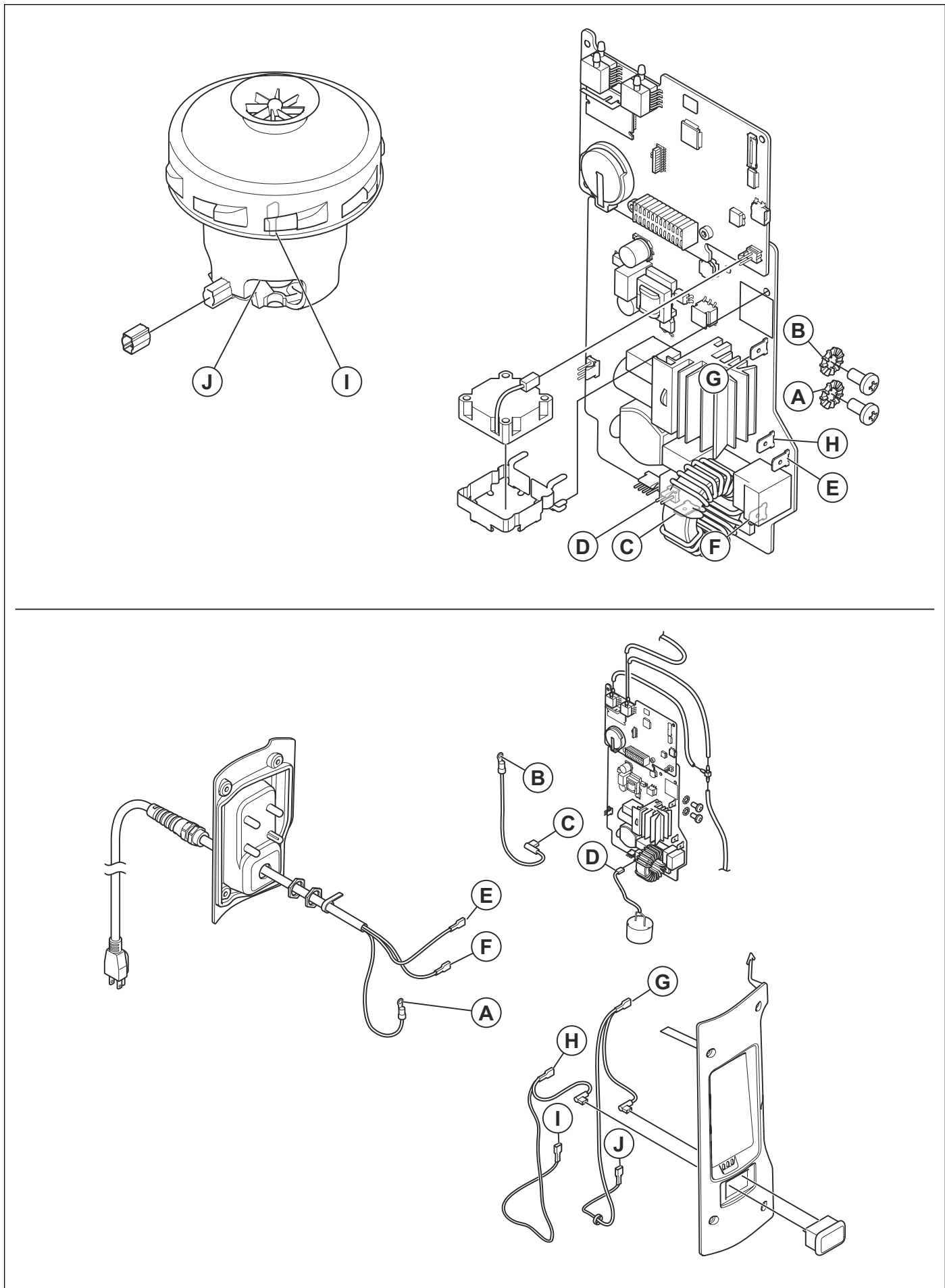

10.4 Wiring diagram DE 110 SH, US/UK/JPN

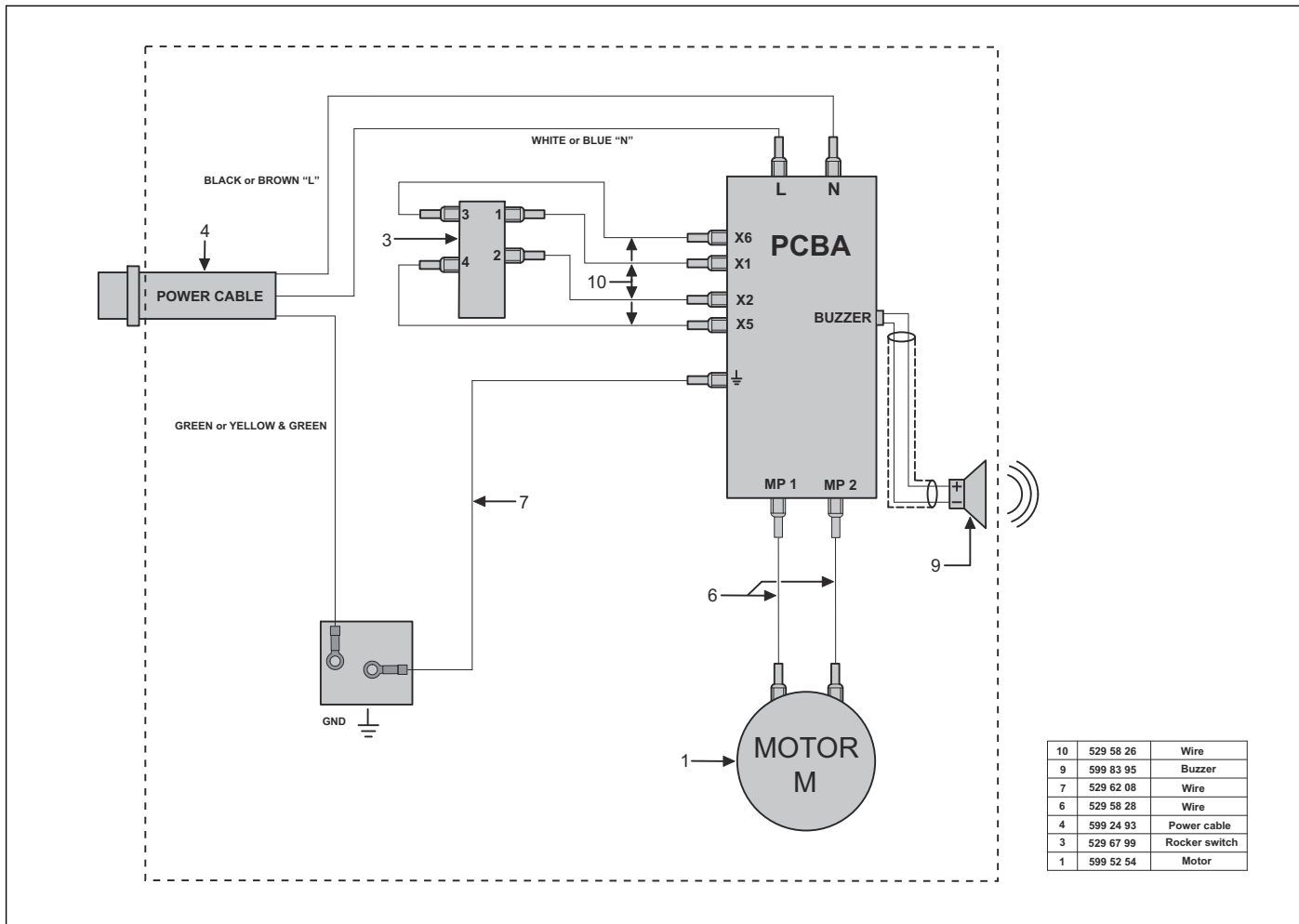

10.5 Wiring diagram DE 110i H

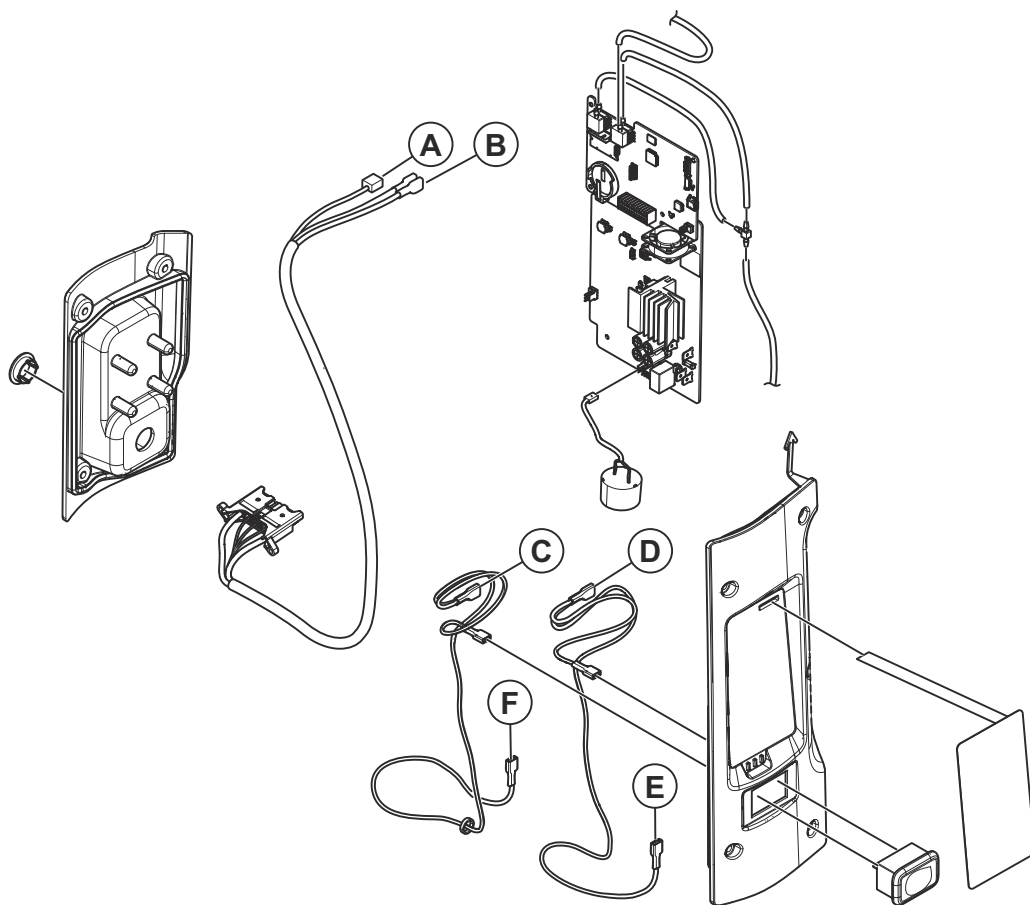
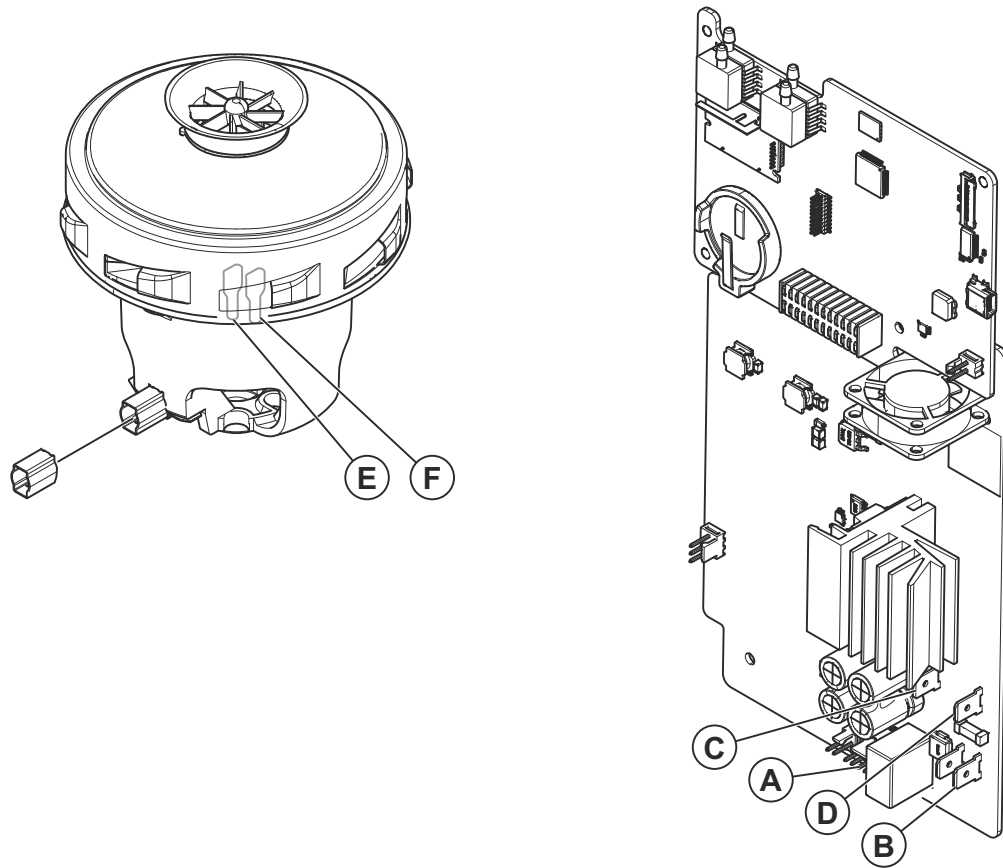

10.7 Wiring diagram DE 110 H, EU/AUS

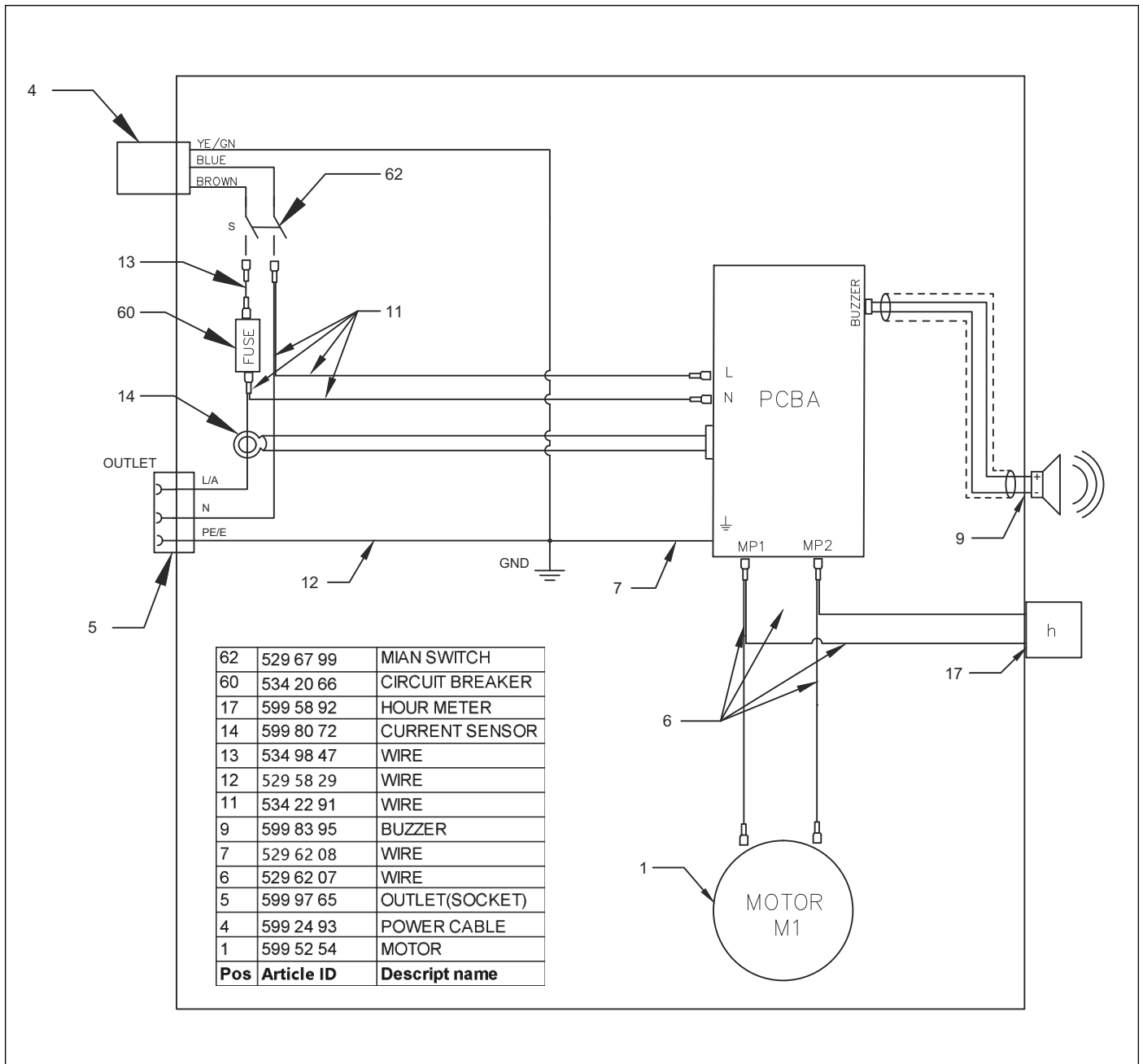

10.8 Wiring diagram DE 110 H, UK/JP/US

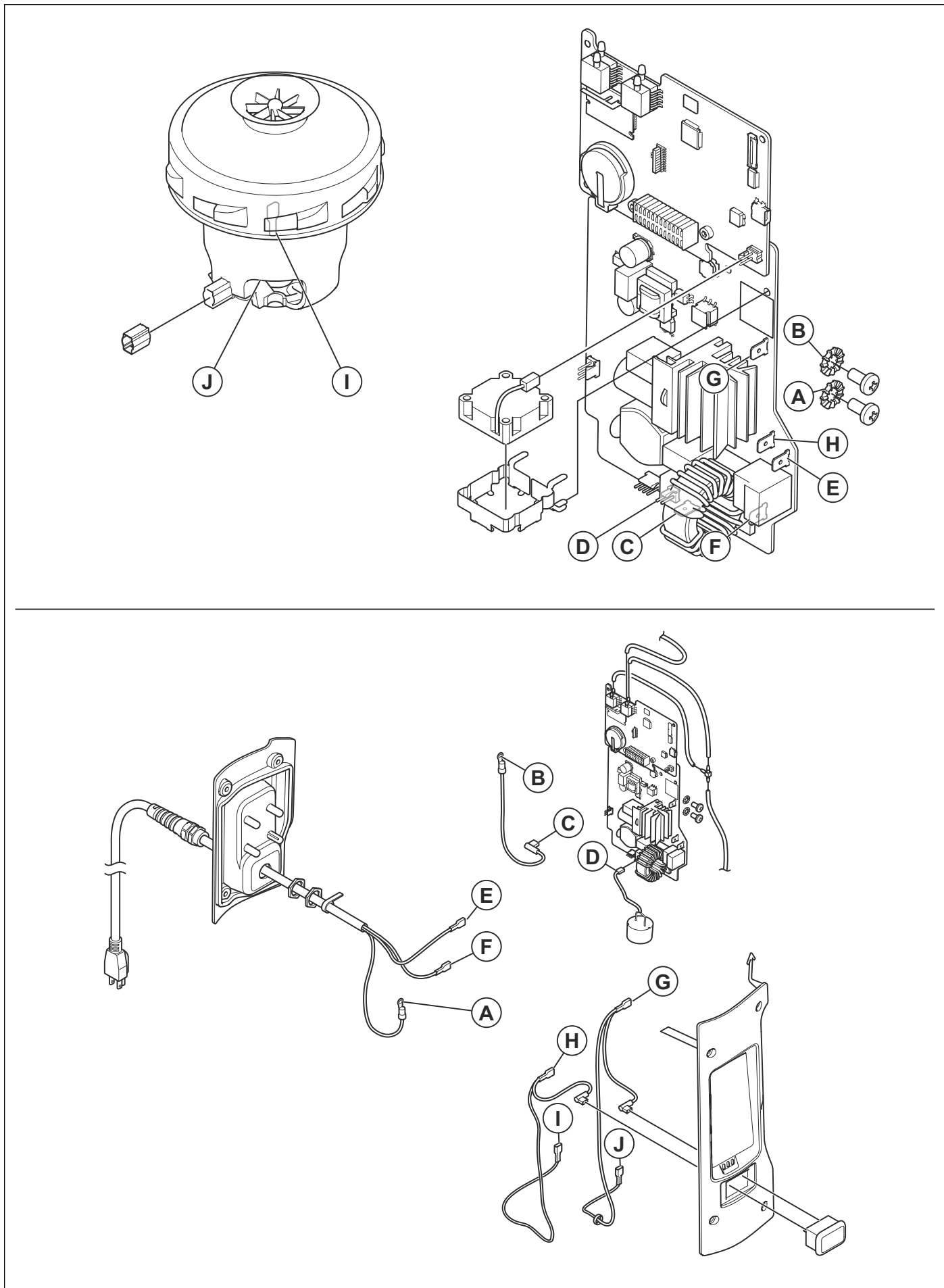

10.9 Wiring diagram DE 110 H, UK

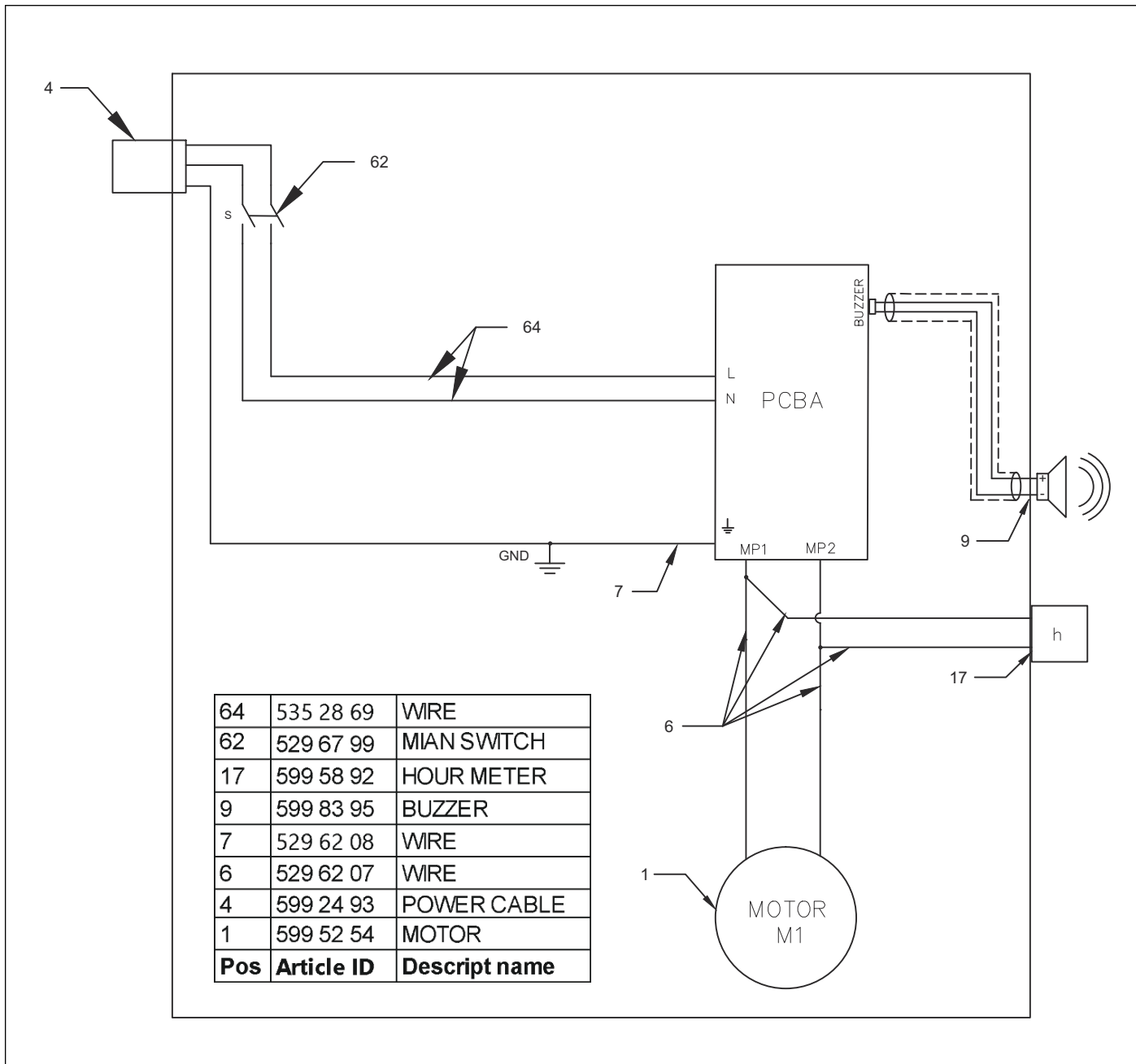

10.10 Wiring diagram DE 110 H, JP

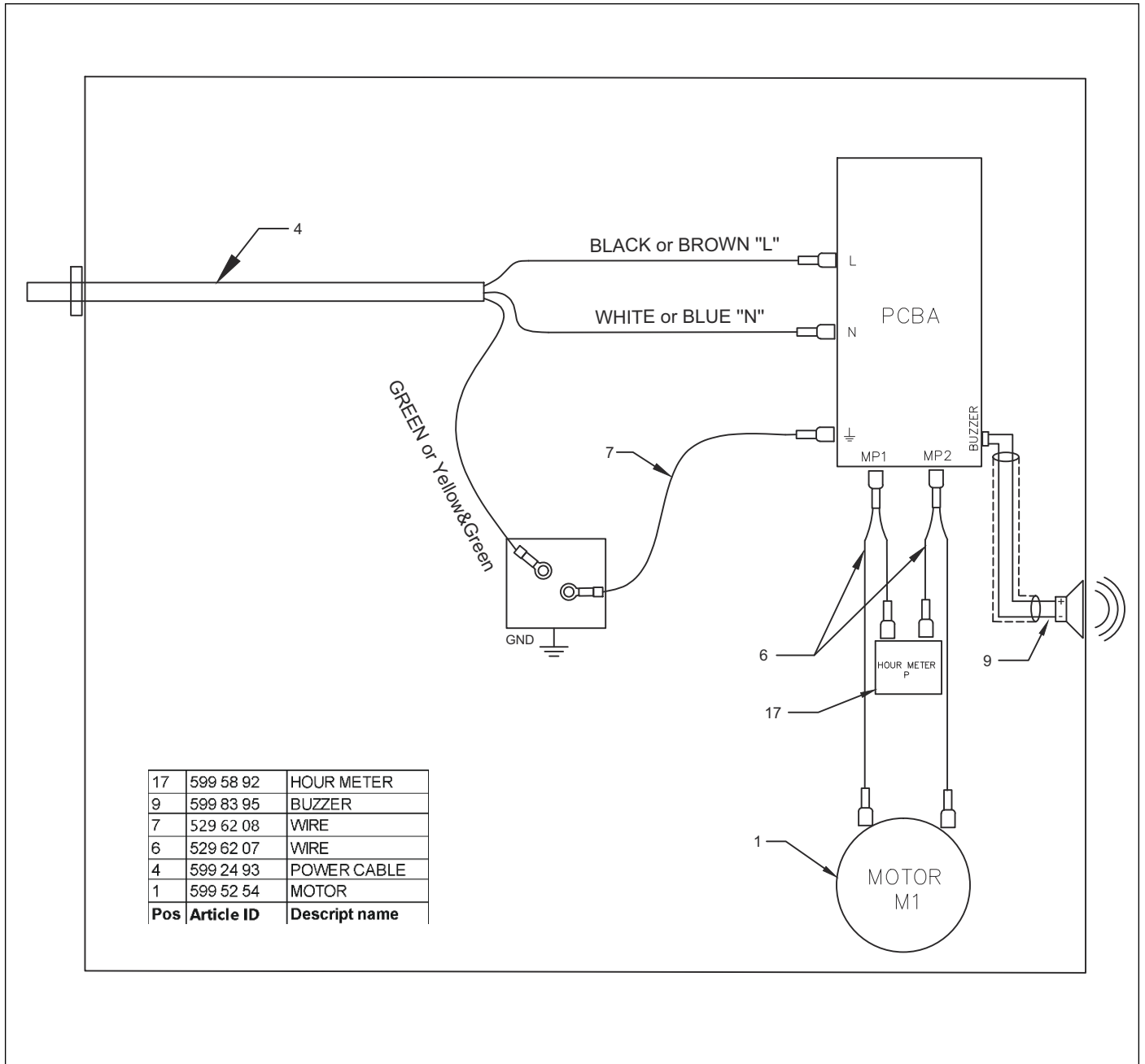

10.11 Wiring diagram DE 110 H, US

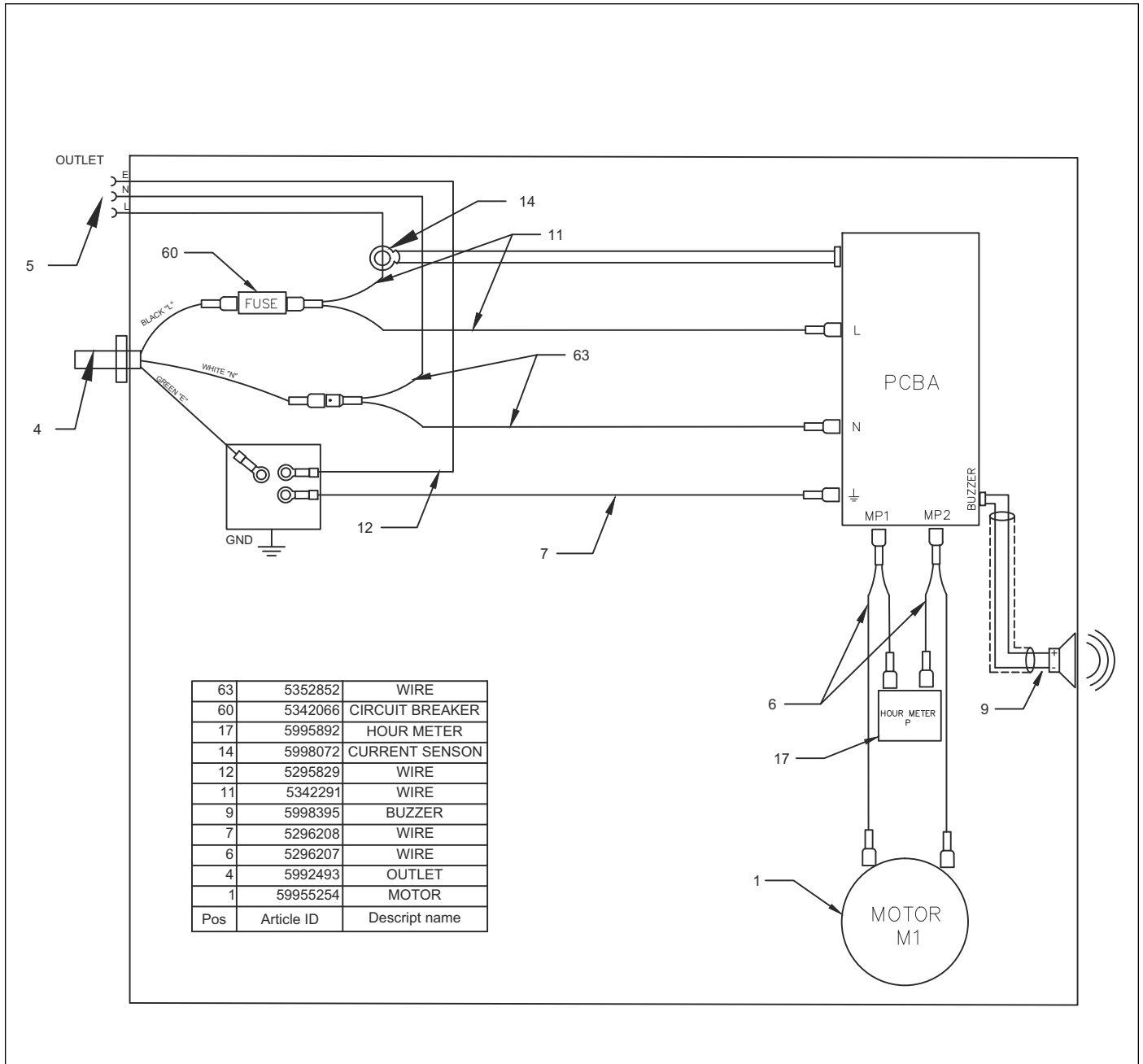

10.12 Wiring diagram DE 120 H EU/AUS

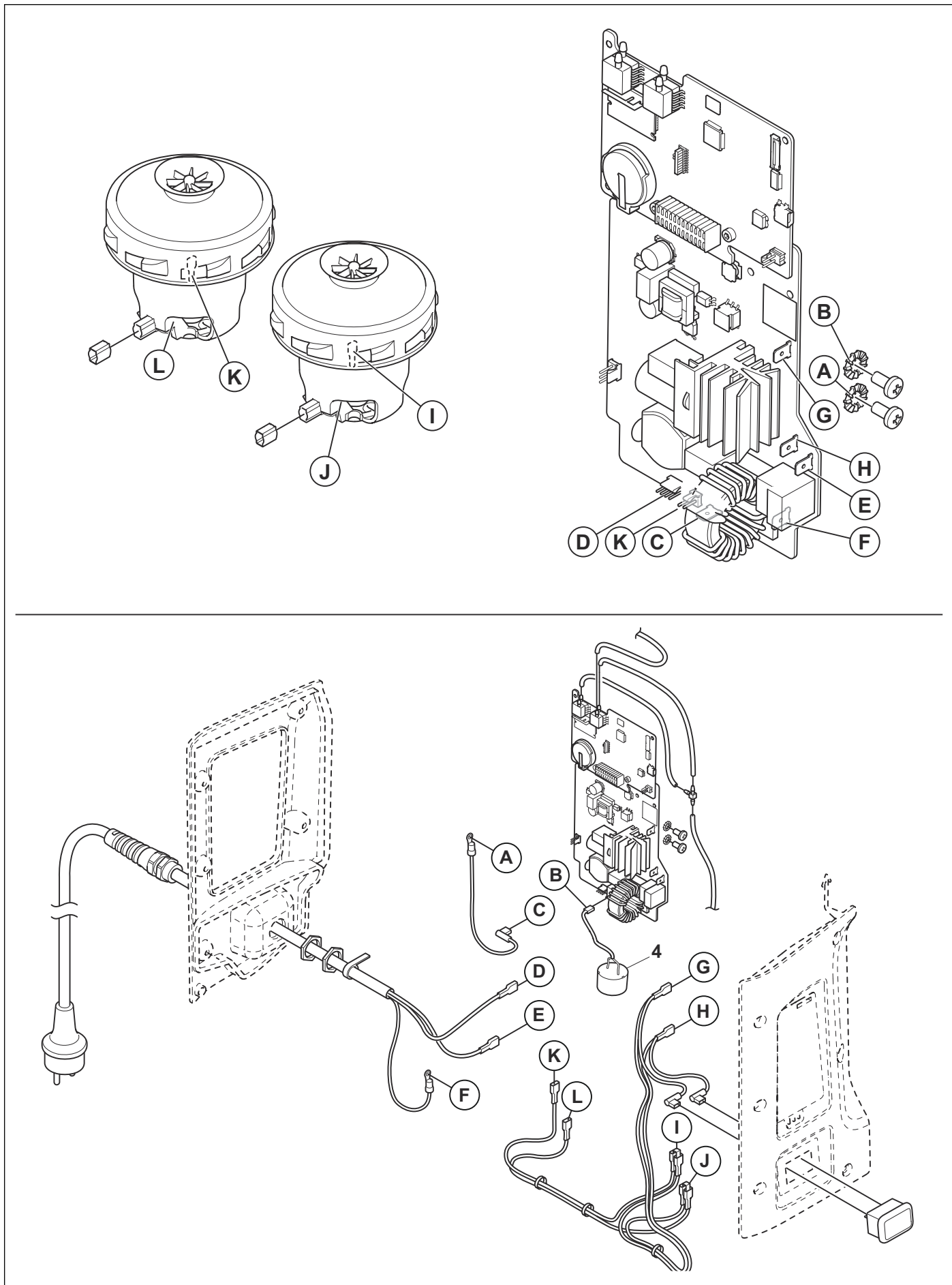

10.13 Wiring diagram DE 120 H EU/AUS/UK

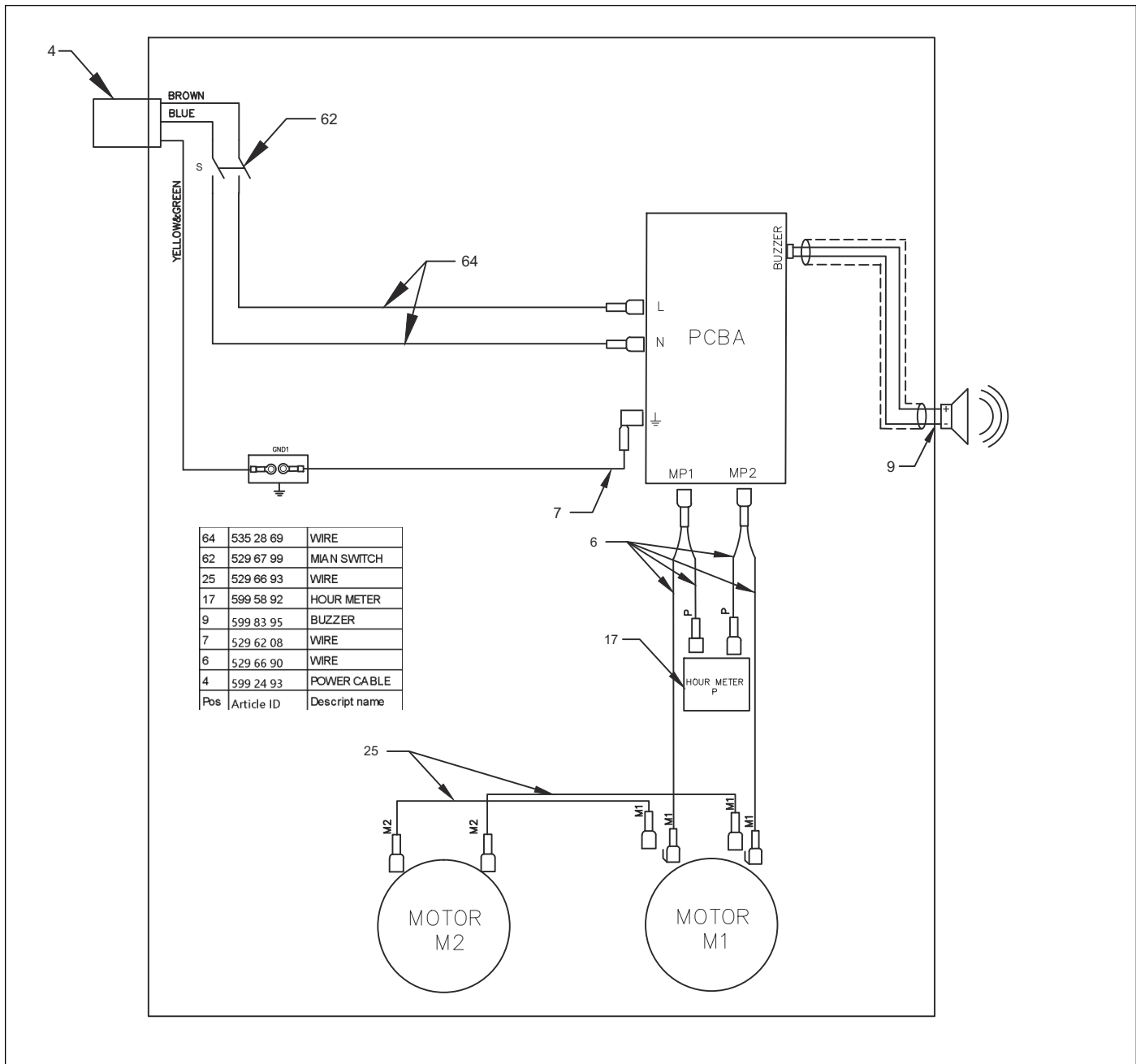

10.14 Wiring diagram DE 120 H US/JP

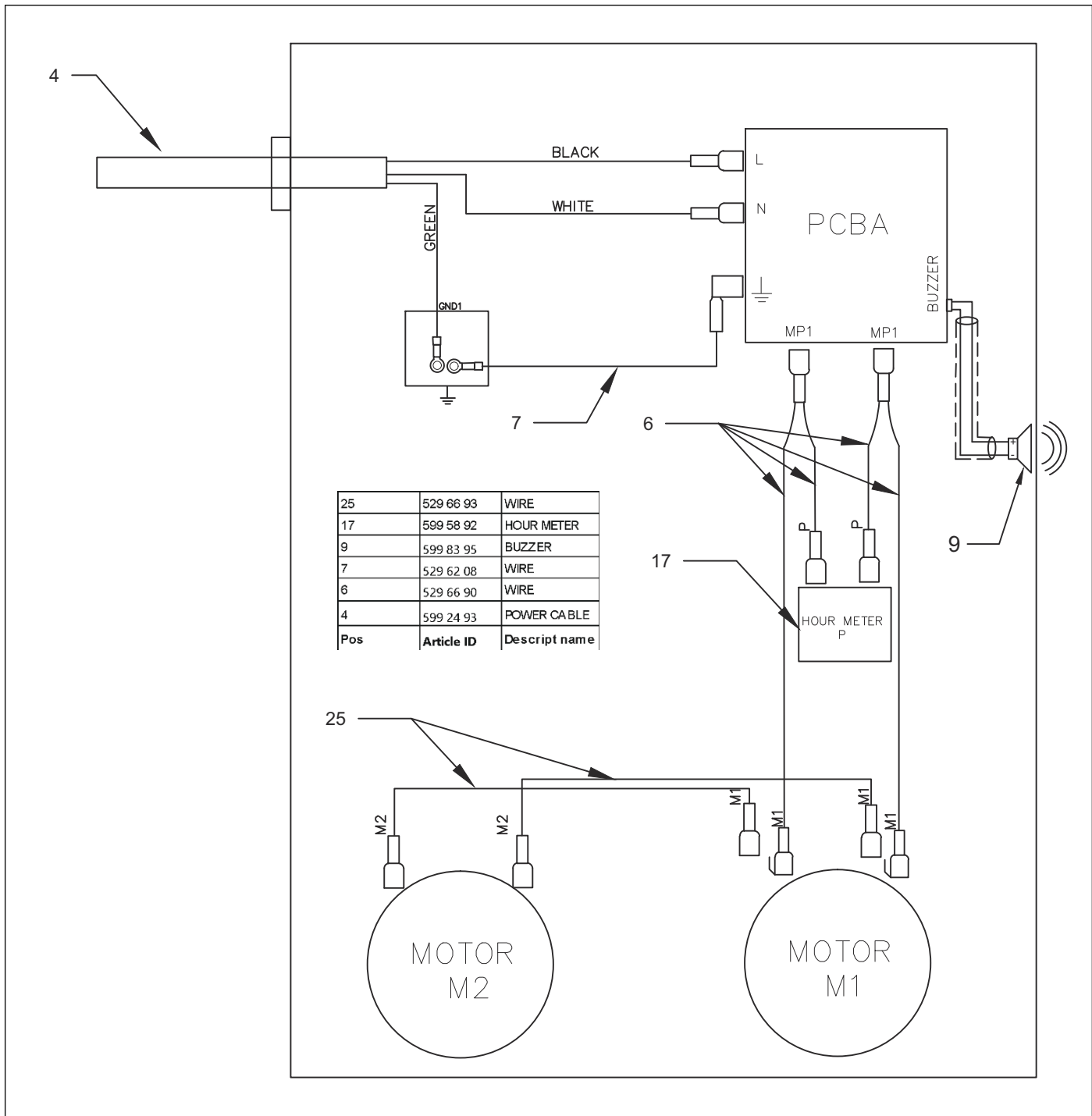

10.15 Wiring diagram DE 120 H PACE

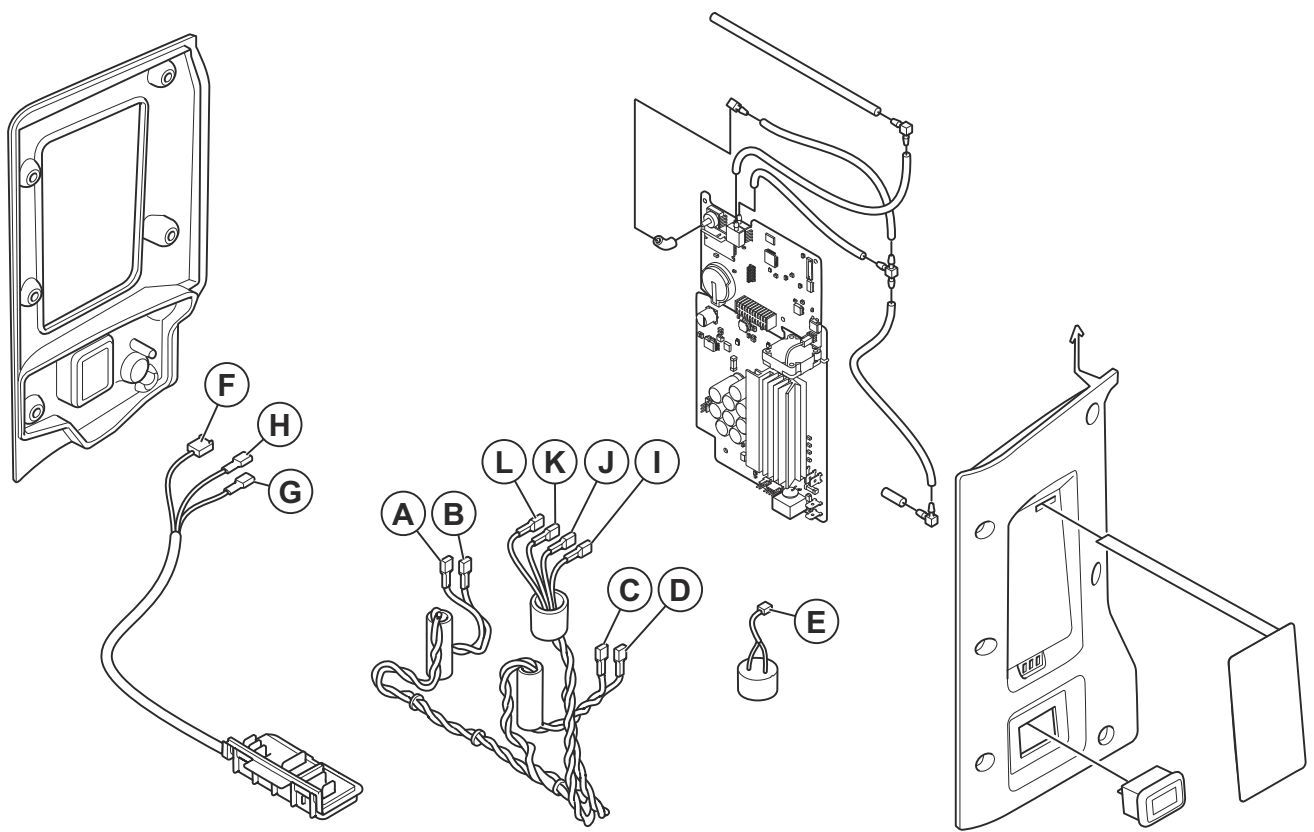
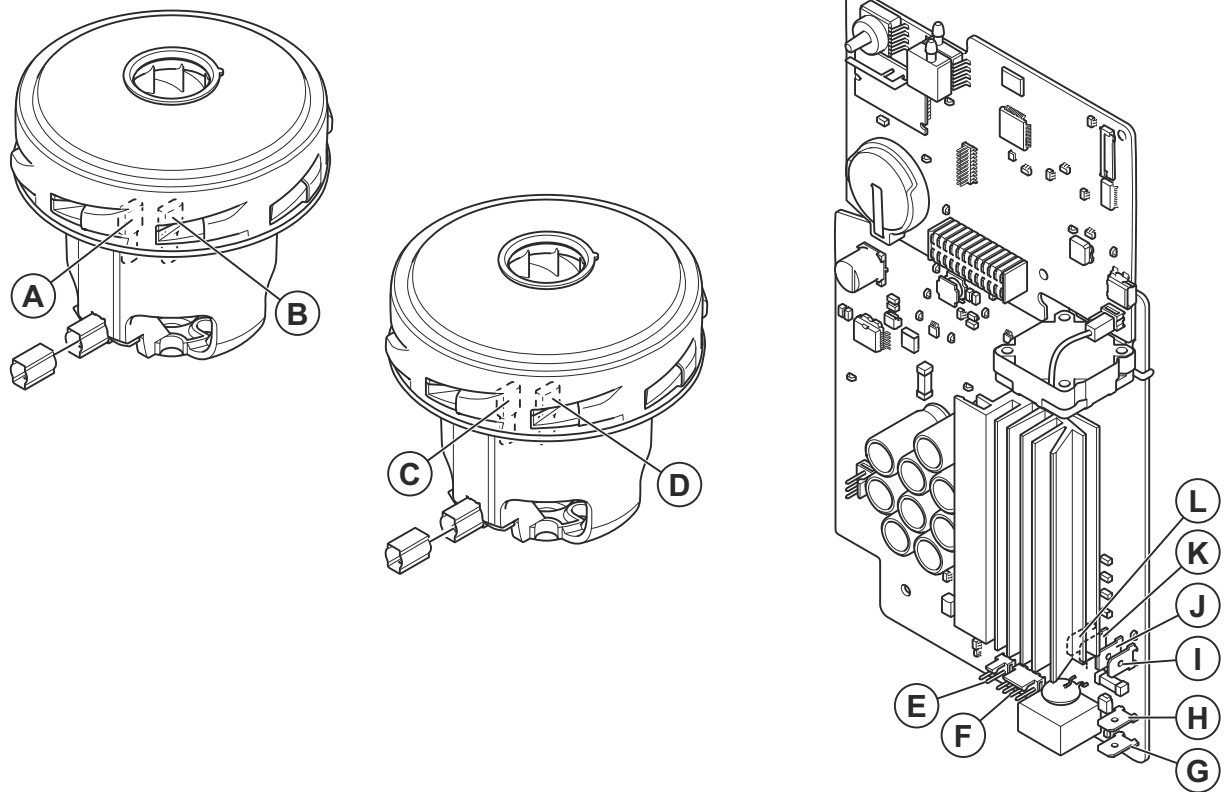

10.16 Wiring diagram DE 120 H PACE

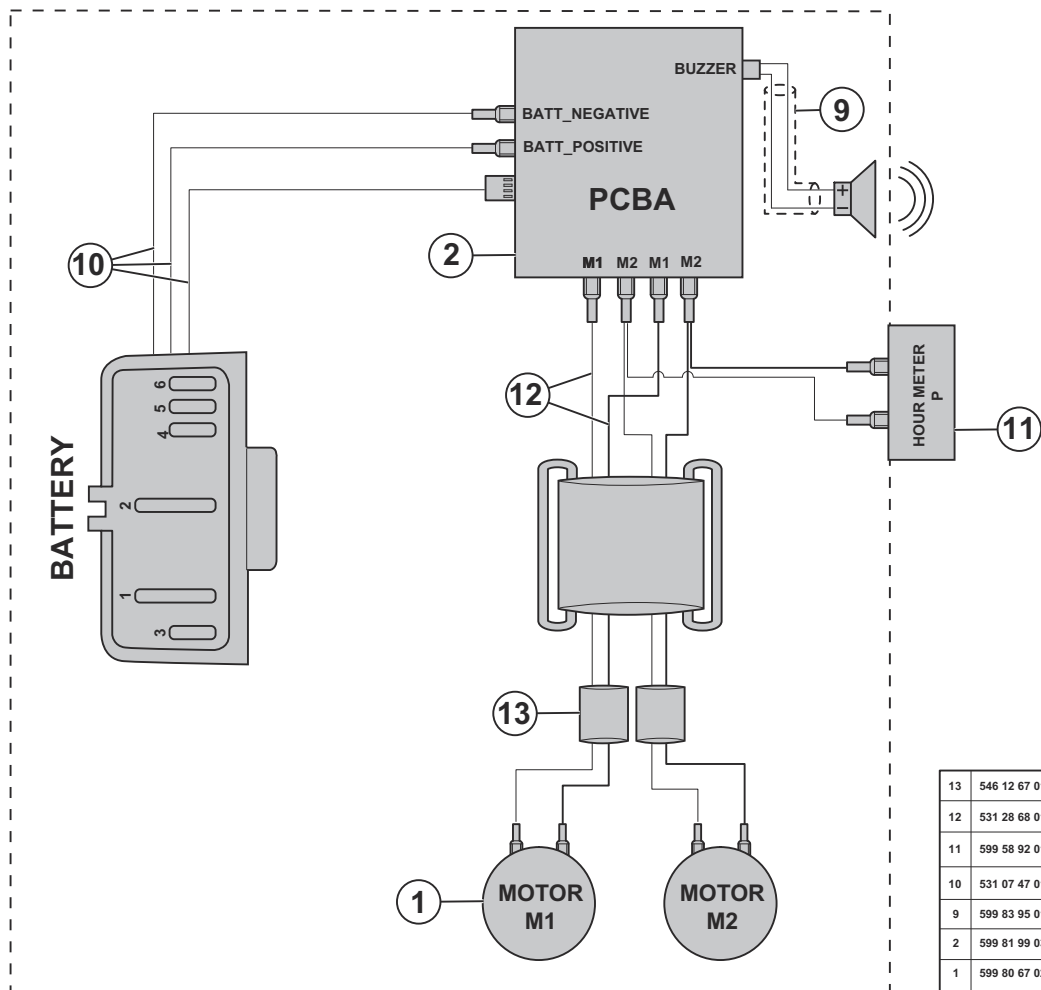

11 Technical data

11.1 Technical data DE 110i H EU

Data	DE 110i H
Power source	Battery
Rated voltage, V	36
Maximum power, W	900
Maximum current, A	20
Maximum airflow, cfm / m ³ /h	118 / 200
Maximum vacuum, psi / kPa / in. H ₂ O	2.5 / 17 / 68
Auxiliary outlet	No
Prefilter area, ft ² / m ²	15.4 / 1.4
Filter efficiency HEPA	HEPA 13
Total HEPA area, ft ² / m ² HEPA 13	12.7 / 1.2
Dust collection system, type	Longopac
Filter cleaning mechanism	Jet Pulse
Dimensions L×W×H, in. / mm	26.4×15.7×39.4 / 670×400×1000
Weight, lbs / kg	57 / 26
Sound power level L _{WA} measured, dB(A) ¹	83.6
Sound pressure level L _{PA} at the operators ear, dB(A) ²	68.3
Vibration level a _h , m/s ²³	≤2.5
Protection class	IP44

11.2 Technical data DE 110i H US

Data	DE 110i H
Power source	Battery
Rated voltage, V	36
Maximum power, W	900
Maximum current, A	20
Maximum airflow, cfm / m ³ /h	118 / 200
Maximum vacuum, psi / kPa / in. H ₂ O	2.5 / 17 / 68
Auxiliary outlet	No
Prefilter area, ft ² / m ²	15.4 / 1.4
Filter efficiency HEPA	HEPA 13
Total HEPA area, ft ² / m ² HEPA 13	12.7 / 1.2
Dust collection system, type	Longopac
Filter cleaning mechanism	Jet Pulse

¹ Noise emissions in the environment measured as sound power (LWA) in conformity with EN 60335-2-69. Uncertainty Kwa 2dB.

² Noise pressure level according to EN 60335-2-69. Uncertainty KPA 2dB.

³ Vibration level according to EN 60335-2-69. Reported data for vibration level has a typical statistical dispersion (standard deviation) of 1 m/s².

Data	DE 110i H
Dimensions L×W×H, in. / mm	26.4×15.7×39.4 / 670×400×1000
Weight, lbs / kg	57 / 26
Sound power level L _{WA} measured, dB(A) ⁴	83.6
Sound pressure level L _{PA} at the operators ear, dB(A) ⁵	68.3
Vibration level a _h , m/s ²⁶	≤2.5
Protection class	IP44

11.3 Technical data DE 110 SH, DE 110 H, DE 120 H EU

Data	DE 110 SH [UK]	DE 110 SH [EU/ROW]	DE 110 SH [AU]	DE 110 SH [BR]	DE 110 H [UK]	DE 110 H [EU/ROW]	DE 110 H [AU]	DE 110 H [BR]	DE 120 H [UK]	DE 120 H [EU/AU/ROW]
Rated Voltage, V	110	220-240			110	220-240			110	220-240
Phase	1									
Frequency, Hz	50-60									
Maximum power, W	900			1100			2200			
Maximum current, A	7.5	4			9.5	5			19	10
Maximum airflow turbine, m ³ /h / cfm	200 / 118	215 / 127			225 / 132	240 / 141			450 / 265	480 / 283
Maximum airflow extractor, m ³ /h / cfm	170 / 100	180 / 106			195 / 115	210 / 124			380 / 224	410 / 241
Maximum vacuum turbine, kPa / psi / in. H ₂ O	20 / 2.9 / 80									
Dust extraction hose length, m / ft	5.0 / 16.4								7.5 / 24.6	
Dust extraction hose diameter mm / in.	38 / 1.5								51 / 2.0	
Auxiliary outlet	No	Yes	Yes	No	No	Yes	Yes	No	No	
Maximum load auxiliary outlet, W	N/A	2300	1200	N/A	N/A	2300	1200	N/A	N/A	
Total power rating, W	N/A	3200	2100	N/A	N/A	3400	2300	N/A	N/A	
Pre-filter area, m ² / ft ²	1.4 / 15.4								2.7 / 29.5	
Filter efficiency HEPA	HEPA 13									
Total HEPA area, m ² / ft ²	1.2 / 12.7								2.4 / 25.4	
Dust collection system, type	Longopac									
Filter cleaning mechanism	Jet Pulse									

⁴ Noise emissions in the environment measured as sound power (LWA) in conformity with EN 60335-2-69. Uncertainty Kwa 2dB.

⁵ Noise pressure level according to EN 60335-2-69. Uncertainty KPA 2dB.

⁶ Vibration level according to EN 60335-2-69. Reported data for vibration level has a typical statistical dispersion (standard deviation) of 1 m/s².

Data	DE 110 SH [UK]	DE 110 SH [EU/ROW]	DE 110 SH [AU]	DE 110 SH [BR]	DE 110 H [UK]	DE 110 H [EU/ROW]	DE 110 H [AU]	DE 110 H [BR]	DE 120 H [UK]	DE 120 H [EU/AU/ROW]
Dimensions L×W×H, mm / in.	670×400×1000 / 26.4×15.7×39.4								815×542×1125 / 32.1×21.3×44.3	
Weight, kg / lbs	25 / 55								39 / 86	
Sound power level L_{WA} measured, dB(A) ⁷	92.2								97.3	
Sound pressure level L_{PA} at the operators ear, dB(A) ⁸	77								81.6	
Vibration level a_{rh} , m/s ²⁹	≤2.5									
Protection class	IP54								IP55	
Mains connection (type)	IEC 60309 100V 16A	Schuko CEE 7/7	AS/NZ S 3112 10A / NBR 14136 10A	AS/NZ S 3112 10A / NBR 14136 10A	IEC 60309 100V 16A	Schuko CEE 7/7	AS/NZ S 3112 10A / NBR 14136 10A	AS/NZ S 3112 10A / NBR 14136 10A	2P+G 4H 32A 110V	Schuko CEE 7/7 / AS/NZS 3112 10A

11.4 Technical data DE 110 SH, DE 110 H, DE 120 H US

Data	DE 110 SH	DE 110 H	DE 120 H	DE 120 H
Rated Voltage, V	120			230
Phase	1			
Frequency, Hz	50–60			
Maximum power, W	900	1100	2200	
Maximum current, A	7.5	9.5	19	10
Maximum airflow turbine, cfm / m ³ /h	127 / 215	141 / 240	283 / 480	
Maximum airflow extractor, cfm / m ³ /h	106 / 180	124 / 210	241 / 410	
Maximum vacuum turbine, psi / kPa / in. H ₂ O	2.9 / 20 / 80			
Dust extraction hose length, ft / m	16.4 / 5.0		24.6 / 7.5	
Dust extraction hose diameter in. / mm	1.5 / 38		2.0 / 51	
Auxiliary outlet	No	Yes	No	
Maximum load auxiliary outlet, A	N/A	10	N/A	
Prefilter area, ft ² / m ²	15.4 / 1.4		29.5 / 2.7	
Filter efficiency HEPA	HEPA 13			
Total HEPA area, ft ² / m ² HEPA 13	12.7 / 1.2		25.4 / 2.4	
Dust collection system, type	Longopac			
Filter cleaning mechanism	Jet Pulse			

⁷ Noise emissions in the environment measured as sound power (LWA) in conformity with IEC/EN 60335-2-69. Uncertainty Kwa 2dB.

⁸ Noise pressure level according to IEC/EN 60335-2-69. Uncertainty KPA 2dB.

⁹ Vibration level according to IEC/EN 60335-2-69. Reported data for vibration level has a typical statistical dispersion (standard deviation) of 1 m/s².

Data	DE 110 SH	DE 110 H	DE 120 H	DE 120 H
Dimensions L×W×H, in. / mm	26.4×15.7×39.4 / 670×400×1000		32.1×21.3×44.3 / 815×542×1125	
Weight, lbs / kg	55 / 25		86 / 39	
Sound power level L _{WA} measured, dB(A) ¹⁰	92.2		97.3	
Sound pressure level L _{PA} at the operators ear, dB(A) ¹¹	77		81.6	
Vibration level a _n , m/s ² ¹²	≤2.5			
Protection class	IP54		IP55	
Mains connection (type)	Nema 5-15P		Nema 5-20P	NEMA L6-20 250V 20A

11.5 Technical data DE 110 SH, DE 110 H, DE 120 H JA

Data	DE 110 SH	DE 110 H	DE 120 H
Rated Voltage, V	100		
Phase	1		
Frequency, Hz	50–60		
Maximum power, W	1100		1500
Maximum current, A	11		15
Maximum airflow turbine, m ³ /h / cfm	240 / 141		380 / 224
Maximum airflow extractor, m ³ /h / cfm	210 / 124		320 / 188
Maximum vacuum turbine, kPa / psi	20 / 2.9		17 / 2.4
Dust extraction hose length, m / ft	5.0 / 16.4		7.5 / 24.6
Dust extraction hose diameter mm / in.	38 / 1.5		51 / 2.0
Auxiliary outlet	No		
Maximum load auxiliary outlet , W	N/A		
Prefilter area, m ² / ft ²	1.4 / 15.4		2.7 / 29.5
Filter efficiency HEPA	HEPA 13		
Total HEPA area, m ² / ft ² HEPA 13	1.2 / 12.7		2.4 / 25.4
Dust collection system, type	Longopac		
Filter cleaning mechanism	Jet Pulse		
Dimensions L×W×H, mm / in.	670×400×1000 / 26.4×15.7×39.4		815×542×1125 / 32.1×21.3×44.3
Weight, kg / lbs	25 / 55		39 / 86
Sound power level L _{WA} measured, dB(A) ¹³	92.2		97.3

¹⁰ Noise emissions in the environment measured as sound power (LWA) in conformity with EN 60335-2-69. Uncertainty Kwa 2dB.

¹¹ Noise pressure level according to EN 60335-2-69. Uncertainty KPA 2dB.

¹² Vibration level according to EN 60335-2-69. Reported data for vibration level has a typical statistical dispersion (standard deviation) of 1 m/s².

¹³ Noise emissions in the environment measured as sound power (LWA) in conformity with EN 60335-2-69. Uncertainty Kwa 2dB.

Data	DE 110 SH	DE 110 H	DE 120 H
Sound pressure level L_{PA} at the operators ear, dB(A) ¹⁴	77		81.6
Vibration level a_h , m/s ² ¹⁵	≤2.5		
Protection class	IP54		
Mains connection (type)	Nema 5-15P JIS		JIS 8303

11.6 Technical data DE 120 H PACE

Data	DE 120 H PACE
Power source	Battery
Rated voltage, V	94
Maximum power, W	2200
Maximum current, A	17
Maximum airflow, cfm / m ³ /h	259 / 440
Maximum vacuum, psi / kPa / in. H ₂ O	2.9 / 22 / 88
Auxiliary outlet	No
Pre-filter area, ft ² / m ²	29.5 / 2.7
Filter efficiency HEPA	HEPA 13
Total HEPA area, ft ² / m ² HEPA 13	25.4 / 2.7
Dust collection system, type	Longopac
Filter cleaning mechanism	Jet Pulse
Dimensions L×W×H, in. / mm	32.1×21.3×44.3 / 815×542×1125
Weight, lbs / kg	90 / 41
Sound power level L_{WA} measured, dB(A) ¹⁶	97.3
Sound pressure level L_{PA} at the operators ear, dB(A) ¹⁷	81.6
Vibration level a_h , m/s ² ¹⁸	≤2.5
Protection class	IP44

¹⁴ Noise pressure level according to EN 60335-2-69. Uncertainty KPA 2dB.

¹⁵ Vibration level according to EN 60335-2-69. Reported data for vibration level has a typical statistical dispersion (standard deviation) of 1 m/s².

¹⁶ Noise emissions in the environment measured as sound power (LWA) in conformity with EN 60335-2-69. Uncertainty Kwa 2dB.

¹⁷ Noise pressure level according to EN 60335-2-69. Uncertainty KPA 2dB.

¹⁸ Vibration level according to EN 60335-2-69. Reported data for vibration level has a typical statistical dispersion (standard deviation) of 1 m/s².



www.husqvarna.com

1143001-26

2023-05-22