

SIXTYSIX

MOBILE MEDIA WALL



Square
Bear

SIXTYSIX

A MOBILE MEDIA WALL FOR THE BUSY WORKPLACE

Designed for workplaces that require flexibility and need to be reconfigured to suit the task on demand.

Blending seamlessly into the Square Bear mobile accessory range, SIXTYSIX can be moved throughout the office to provide a solution for face-to-face meetings, presentations, virtual meetings and the cheeky need to relax with a movie.

Easily moved for planned or spontaneous activities, SIXTYSIX adapts to the team needs and room use. Options for a magnetic whiteboard or a pinboard on the rear side of the mounted AV screen provides functionality on both sides of the unit with a neat and discreet design for the storage of unsightly cables. Shelving to the lower levels of the unit provide extra storage for whatever the team needs.



SIXTYSIX

MOBILE MEDIA WALL FEATURES

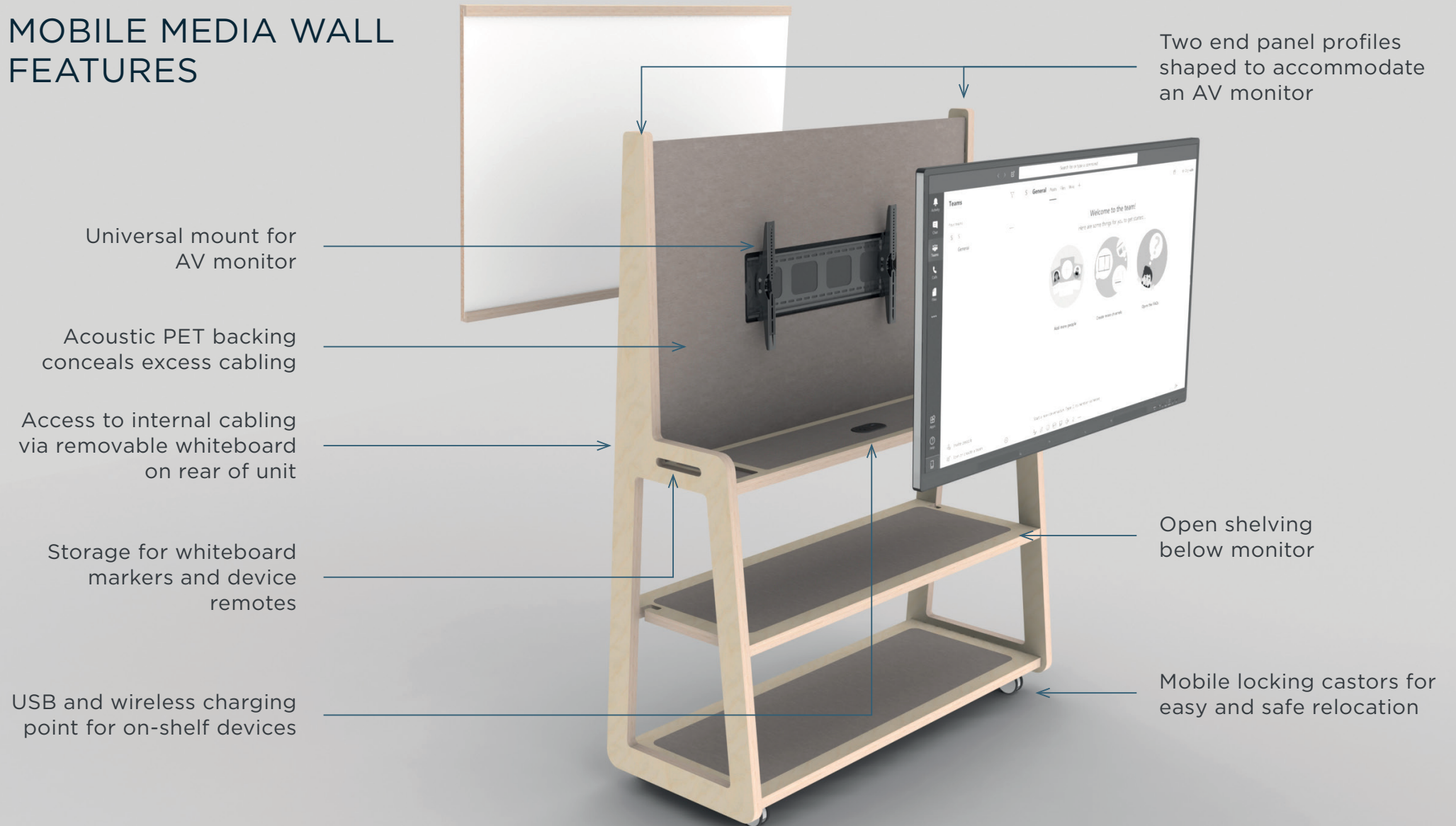

SIXTYSIX

Designed to complement other products within the Square Bear product range including the ETCH mobile whiteboards, and with the capability to nest neatly against the RETREAT acoustic booths when not in use.

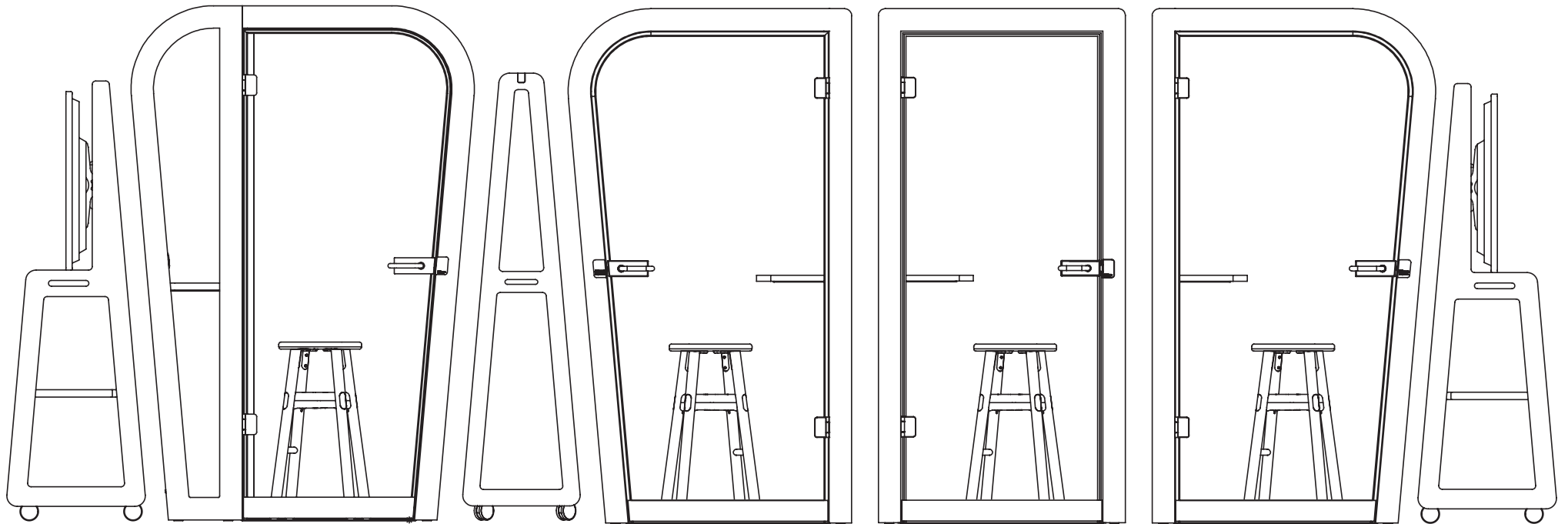

SQUARE BEAR AND SUSTAINABILITY

Sustainability is extremely important to us. Our product designs carefully consider the impact on the environment from the initial concept through to the choice of material, process of production, lifecycle, and recyclability.

Most importantly, we care about people - your people, our people, our supplier's people, and all the people who at some point may end up working in the manufacturing industry.

We are committed to eliminating modern slavery, we carefully select our supply partners, and we double check the suppliers of our supply partners to ensure we are working with people who are aligned with our views on human rights.

We work with consultants to obtain appropriate industry standard certification and to assess our performance on an ongoing basis. We continually consider our environmental impact, social responsibility, and strategies towards a sustainable future.

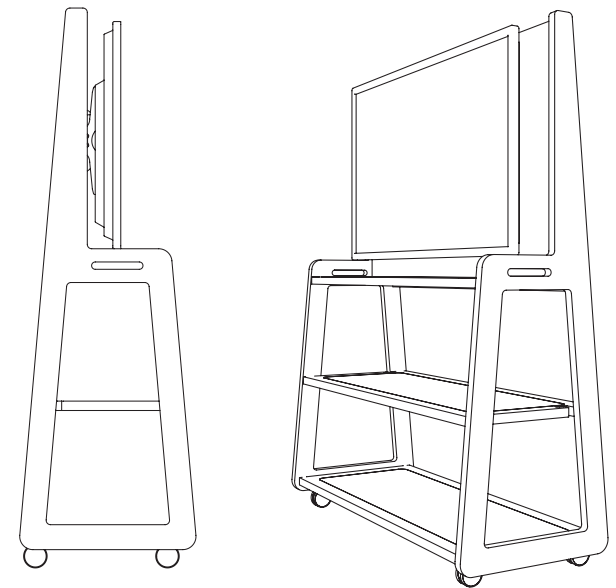

SIXTYSIX

MOBILE MEDIA WALL

sales@square-bear.com

www.square-bear.com



Square
Bear