

SIXTYSIX

Technical Specifications

SIXTYSIX Mobile Media Wall has been designed for workplaces that require flexibility and need to be reconfigured to suit the task on demand. Blending seamlessly into the Square Bear mobile accessory range, SIXTYSIX can be moved throughout the office to provide a solution for face-to-face meetings, presentations, virtual meetings, and the cheeky need to relax with a movie.

Easily moved for planned or spontaneous activities, SIXTYSIX adapts to the team needs and room use. Options for a magnetic whiteboard or a pinboard on the rear of the mounted AV screen means that the unit has functionality on both sides and the design has a neat discreet storage capability to hide unsightly cables. Shelving to the lower levels of the unit provide extra storage for whatever the team needs.



Product Data

1366

suits up to 55" collaboration display

Product dimensions

Overall dimensions	1430W x 600D x 1905mmH
Rear Whiteboard panel	1366W x 930mmH
Acoustic monitor backing	1366W x 870mmH
Monitor mount* (Monitor not supplied)	VESA compatible up to 600 x 400 Max. monitor weight 30kg

Structure

Plywood frame	32mm hoop pine plywood
Whiteboard	Magnetic whiteboard substrate
Acoustic monitor backing	12mm PET Panel
Shelf inlay	12mm PET Panel

Power

Standard - wall / floor power	10amp started lead, 3 metres
Mobile - Battery power	CMS Freedom FR210 series

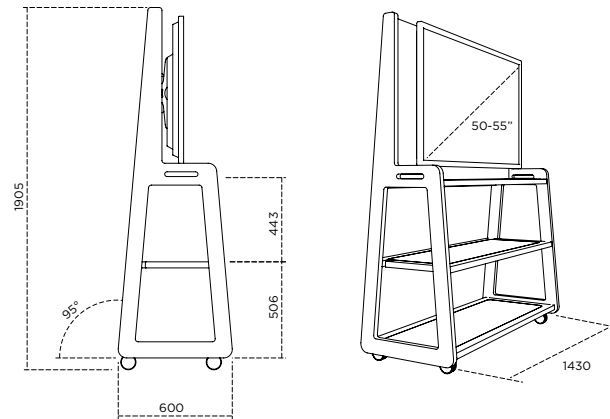

1566

suits up to 65" collaboration display

Product dimensions

Overall dimensions	1630W x 600D x 1905mmH
Rear Whiteboard panel	1566W x 930mmH
Acoustic monitor backing	1566W x 870mmH
Monitor mount (Monitor not supplied)	VESA compatible up to 600 x 400 Max. monitor weight 40kg

Structure

Plywood frame	32mm hoop pine plywood
Whiteboard	Magnetic whiteboard substrate
Acoustic monitor backing	12mm PET Panel
Shelf inlay	12mm PET Panel

Power

Standard - wall / floor power	10amp started lead, 3 metres
Mobile - Battery power	CMS Freedom FR210 series

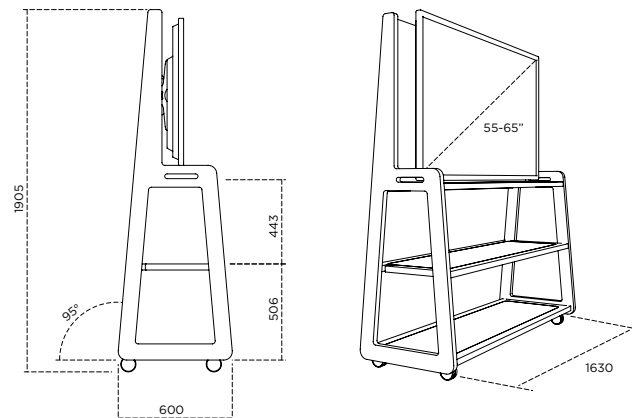

SIXTYSIX

Fixed Power Specification

NW1802RBK *

NW18 Series Dual Auto 10A GPO - Black

SW5205BK **

Tag I/C Cable 500mm - Black

SWT5L30BK ***

10A 3-pin starter - TAG end - Black

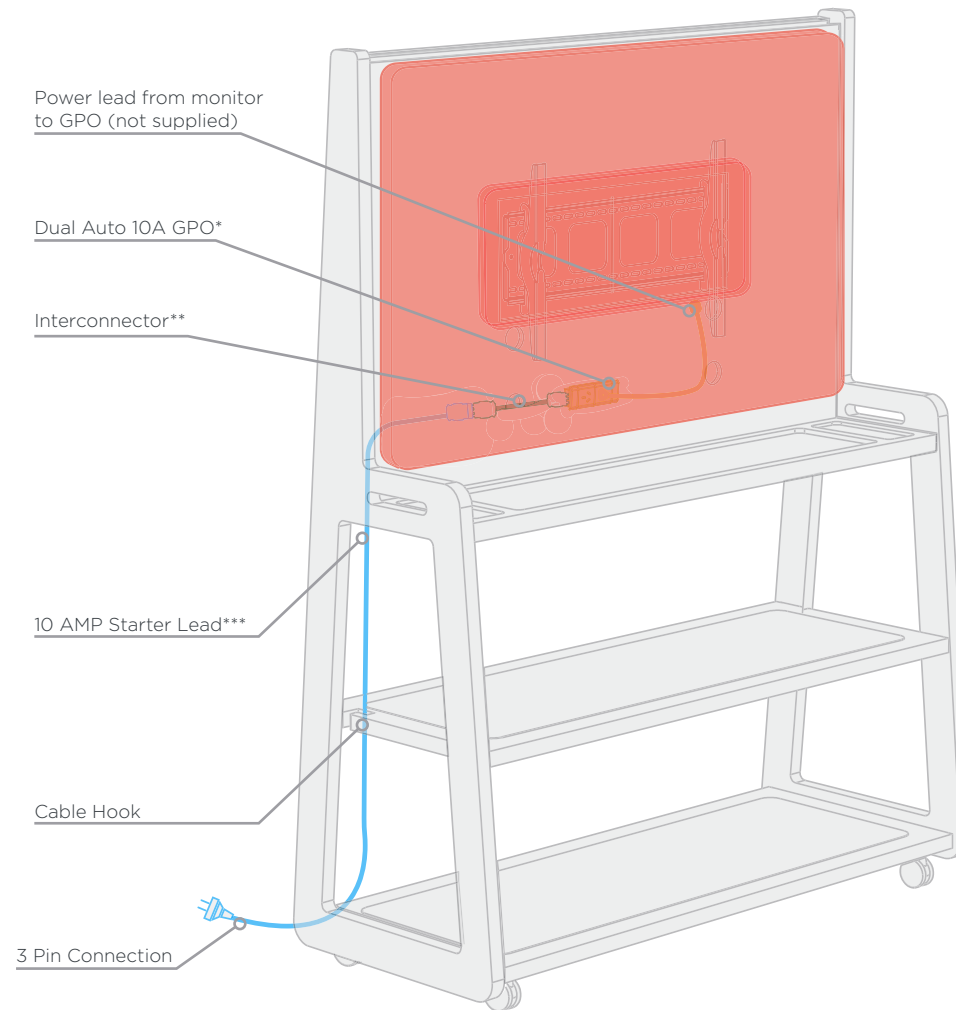

SIXTYSIX

Mobile Power Specification

FR210PBP Power Bank *

Capacity	9,540mAh (206wh)
Charging Output	USB-C Port - PD 100W (5V/3A, 9V/3A, 12V/3A, 15V/3A, 20V/3A,) or QC3.0/2.0 18W (5V/3A, 9V/2A, 12V/1.5A) USB-A Port - QC3.0/2.0 18W (5V/3A, 9V/2A, 12V/1.5A) Total 118W (PD100W and QC18W) USB-C port when factory enabled/(disabled by default): PD 60W max (5V, 9V, 12V, 15V, 20V)
Charging Total	Charging Station
Charging Input Methods	Docking station

FR210DS Docking Station **

Input	7.4x5.0 DC Jack (to recharge units while docked) 20v/5A
Output Ports	USB - C output : PD100W (5V/3A, 9V/3A, 12V/3A, 15V/3A, 20V/3A) or QC3.0/2.0 18W (5V/3A, 9V/2A, 12V/1.5A) USB - A output : QC3.0/2.0 18V (5V/3A, 9V/2A, 12V/1.5A) DC OUT 1 : 18-25.2V, 18-18A DC OUT2 : 12V/18V/20V/24V, 11A Max combined output 150W - 1 docked, 350W 2+ Docked 3x FR210 power banks (630wh)
Docking Capability	

FR210CS Charging Station***

Input	7.4x5.0 DC jack : 20V 7.5A
Max Power Banks	Up to max 5x Power Banks
Charging Time	Charging Station - 5 docked (DC input 150W) 9-10hrs Charging Station - 3 docked (DC input 150W) 6-7hrs Charging Station - 1 docked (DC input 150W) 2-3hrs

FRLA10BK XT60 Lead****

XT60 Plug to XT60 Socket, 1000mm - Black
XT60 Plug to XT60 Socket

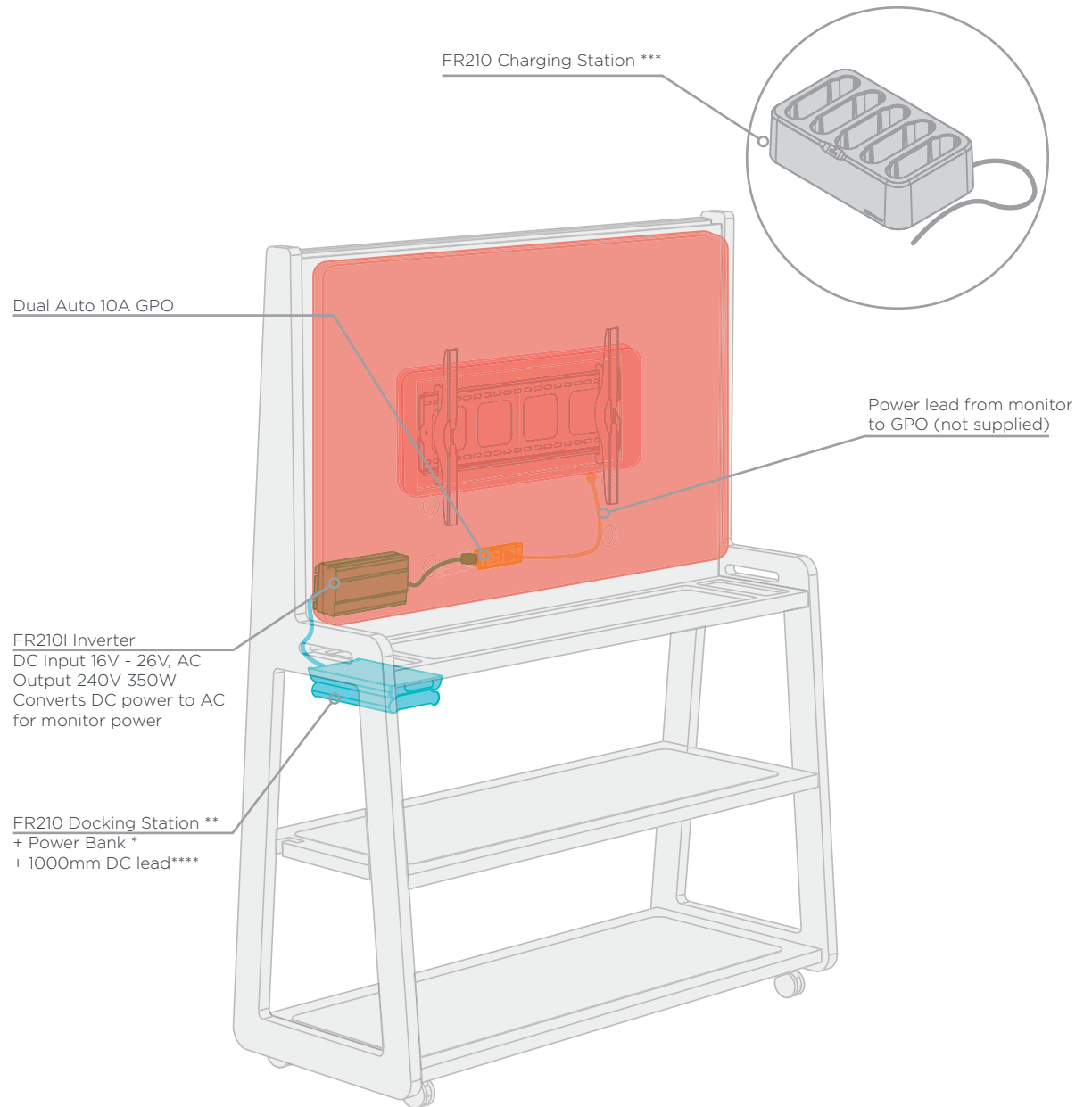

SIXTYSIX

Fixed Power Schematic

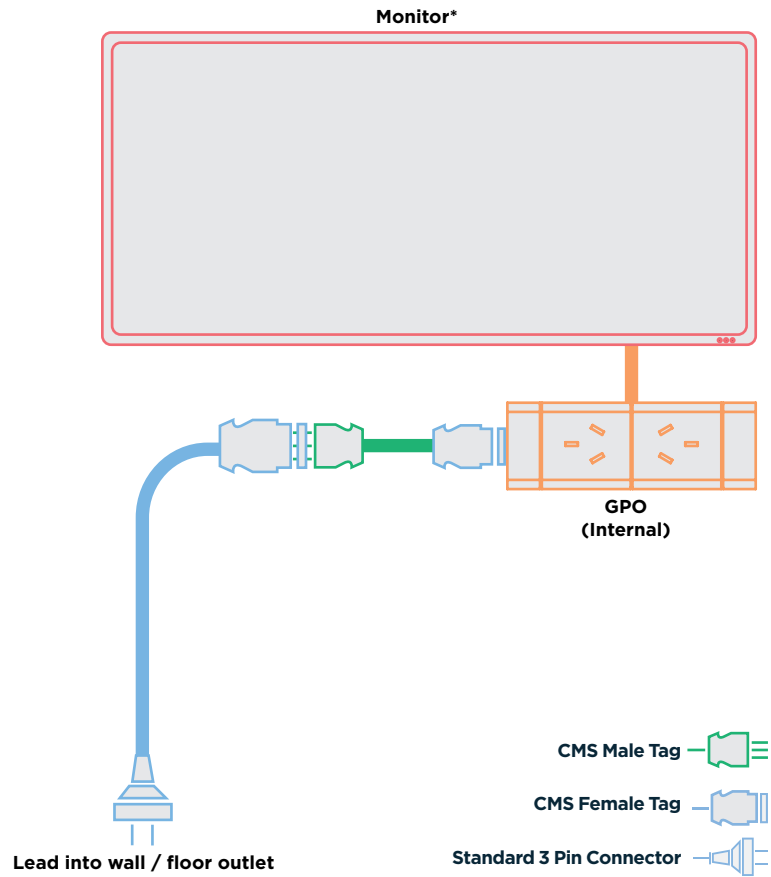

*Monitor not supplied by Square Bear

Mobile Power Schematic

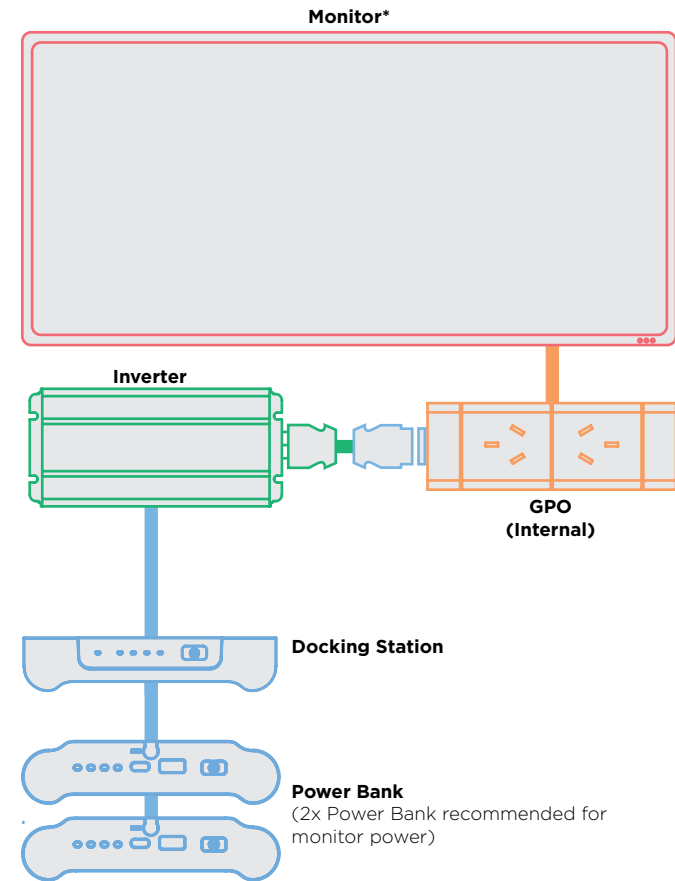

Product Data & Finishes

Product data - common for all configurations

PET

Composition	100% PET, 60-68% recycled
Sustainability	Greentag certified. Greenrate level: A
VOC emission	<0.004mg/m ² /hr

Cleaning

Whiteboard	Refer to product care and maintenance guide
PET / Upholstery	Refer to product care and maintenance guide
Timber	Refer to product care and maintenance guide

Timber finishes

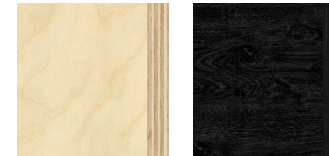

Natural

Black Stain

Pinboard panel finishes

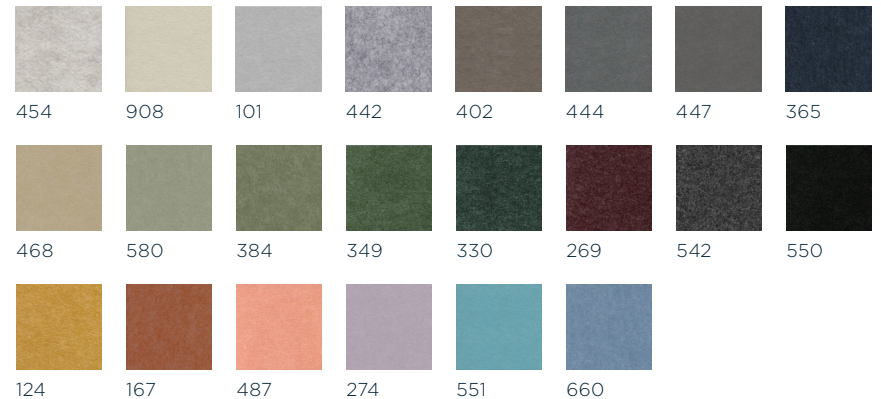

*Contact Square-Bear Acoustics for custom colour options.

Whiteboard panel



Magnetic whiteboard laminate

Power / Battery components



Black

SQUARE BEAR

© Copyright 2021

All Rights Reserved

HEAD OFFICE

Unit 6/80 Jedda Road, Prestons

New South Wales 2170, Australia

P: +61 (0)2 9189 1444

sales@square-bear.com

SYDNEY SHOWROOM

Level 3, 140 William Street, Woolloomooloo

New South Wales 2011, Australia

www.square-bear.com