

TECHLINE 08

1. DETAIL AND DIMENSIONS

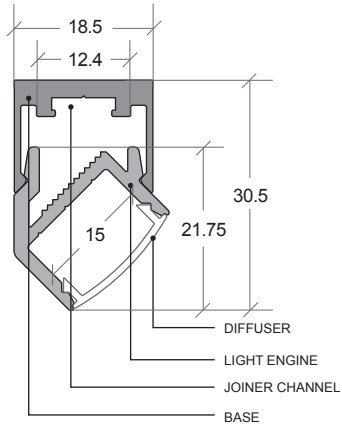

2. MOUNTING OPTIONS

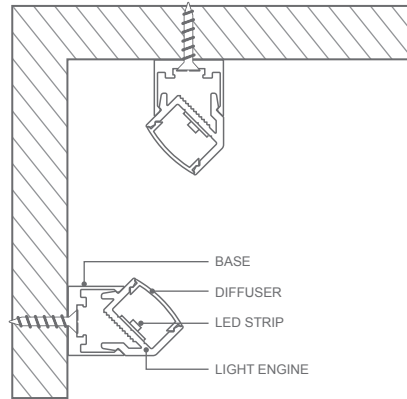

4. ASSEMBLE LED STRIP IN LIGHT ENGINE (prepare off-site as necessary)

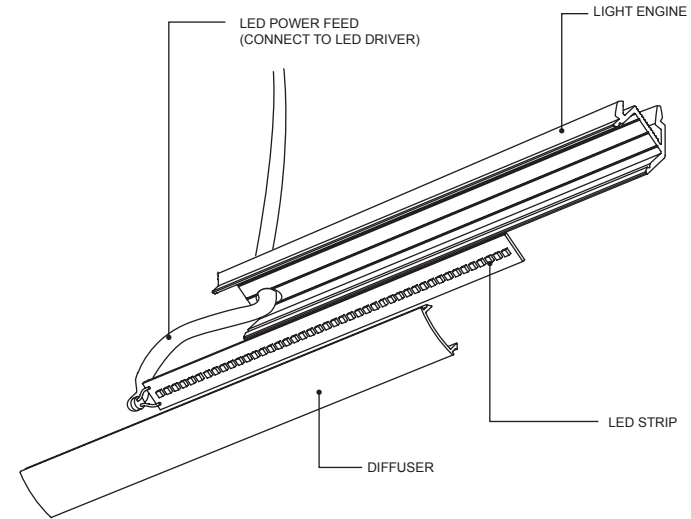

1. IMPORTANT - Before mounting LED strip, clean Light Engine using an alcohol based cleaner.
2. Drill cable entry hole in Light Engine for LED power feed. Thread LED power feed through hole, ensuring it is protected from sharp profile edges e.g. heatshrink or similar.
3. Remove 3M paper from LED strip. Use the guide lines at the back of the light engine as a guide to attach the LED strip.
4. Attach diffuser to Light Engine by clicking in securely.

3. BASE INSTALLATION

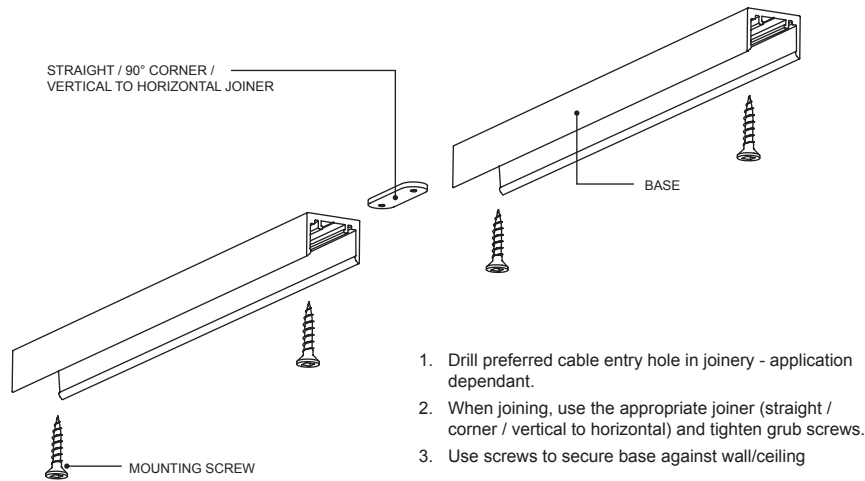

5. LIGHT ENGINE AND DIFFUSER INSTALLATION INTO BASE

