

TECHLINE 05

1. DETAIL AND DIMENSIONS

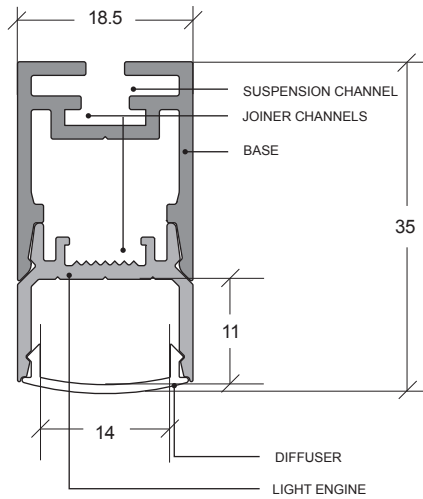

2. BASE INSTALLATION

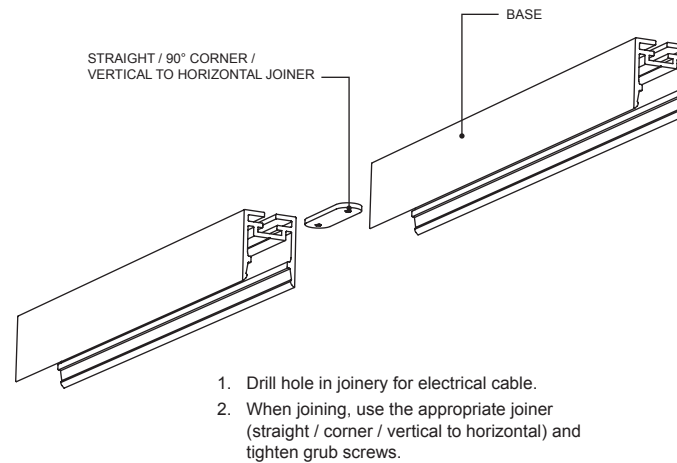

4. LIGHT ENGINE AND DIFFUSER INSTALLATION INTO BASE

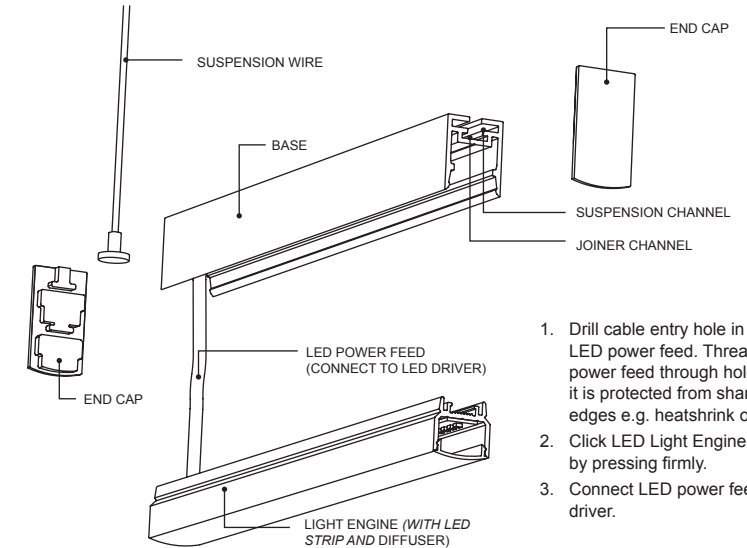

3. ASSEMBLE LED STRIP (prepare off-site as necessary)

1. IMPORTANT - Before mounting LED strip, clean Light Engine using an alcohol based cleaner.
2. Drill cable entry hole in Light Engine for LED power feed. Thread LED power feed through hole, ensuring it is protected from sharp profile edges e.g. heatshrink or similar.
3. When joining, use the appropriate joiner (straight / corner / vertical to horizontal) and tighten grub screws.
4. Remove 3M paper from LED strip. Use the guide lines at the back of the light engine as a guide to attach the LED strip.
5. Attach diffuser to Light Engine by clicking in securely.

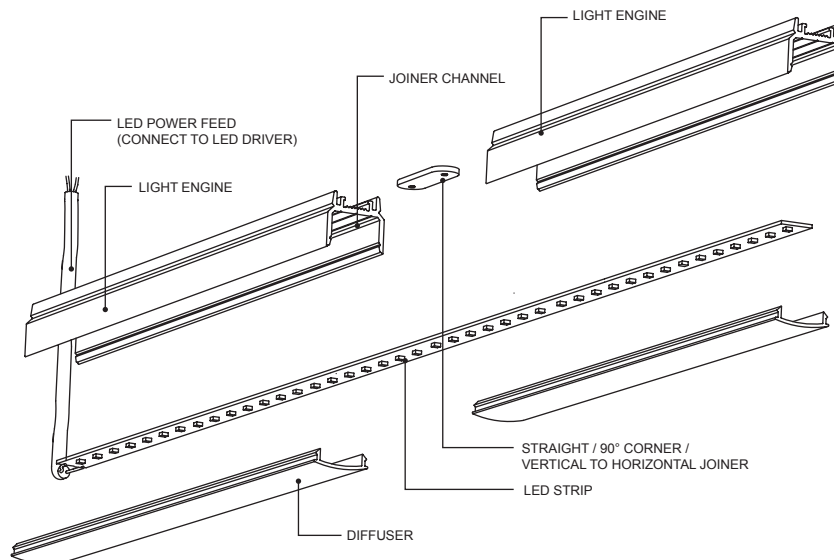

5. BASE SUSPENSION INSTALLATION

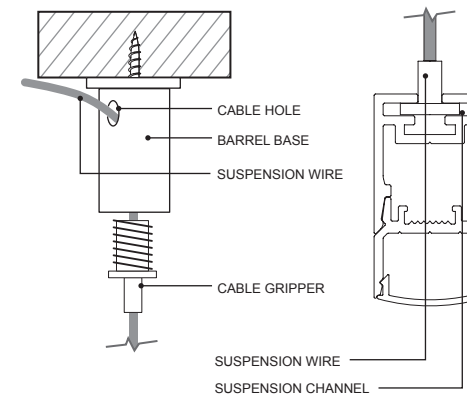

1. Unscrew cable gripper from barrel base and screw barrel to support.
2. Thread suspension cable through cable gripper, barrel base and out cable hole, then rescrew cable gripper.
3. To adjust cable length, pull out through cable hole or press cable gripper inwards to release cable.
4. Slide suspension wires into suspension channel. Position suspension wires 150mm from each end of profile (maximum distance of 2 metres between wires).
5. Secure end caps by pressing into place (may require a touch of silicone). NOTE - End caps are required as part of the install for the TECHLINE range.