

**TECHLINE 02**

**1. DETAIL AND DIMENSIONS**

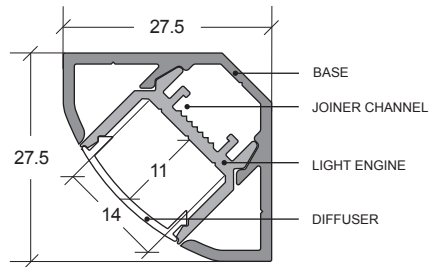

**2. MOUNTING OPTIONS**

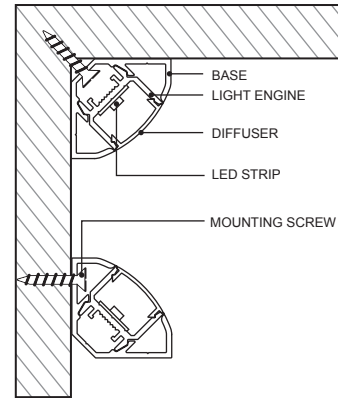

**3. BASE INSTALLATION**

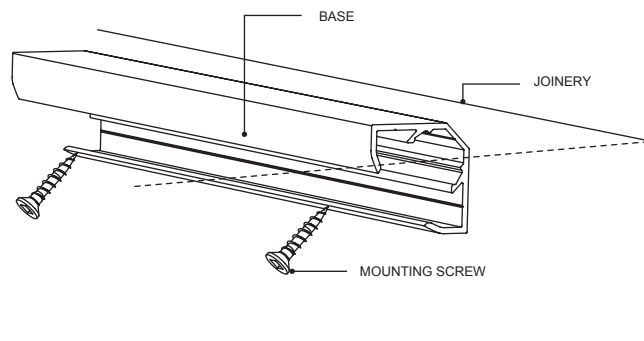

1. Drill preferred cable entry hole in joinery - application dependant.
2. Use screws to secure base against wall/ceiling (see diagram 2 for fastening options)

**4. ASSEMBLE LED STRIP IN LIGHT ENGINE (prepare off-site as necessary)**

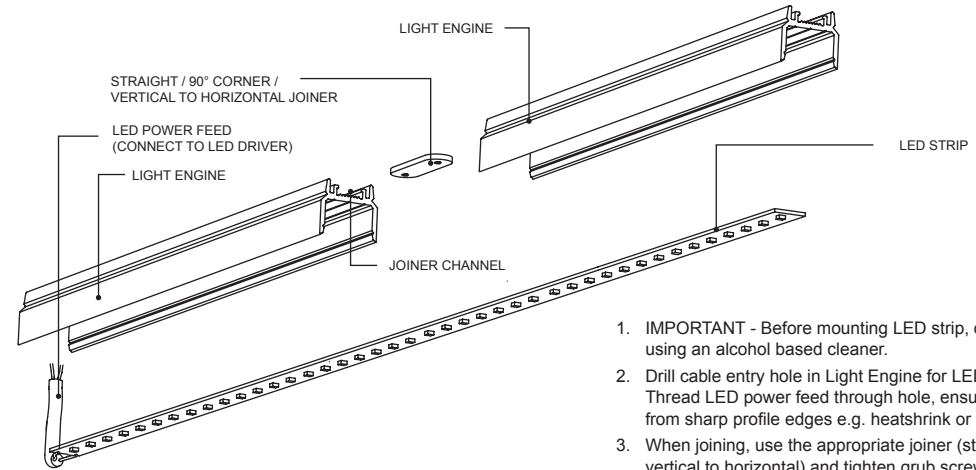

1. IMPORTANT - Before mounting LED strip, clean Light Engine using an alcohol based cleaner.
2. Drill cable entry hole in Light Engine for LED power feed. Thread LED power feed through hole, ensuring it is protected from sharp profile edges e.g. heatshrink or similar.
3. When joining, use the appropriate joiner (straight / corner / vertical to horizontal) and tighten grub screws.
4. Remove 3M paper from LED strip. Use the guide lines at the back of the light engine as a guide to attach the LED strip.

**5. LIGHT ENGINE AND DIFFUSER INSTALLATION INTO BASE**

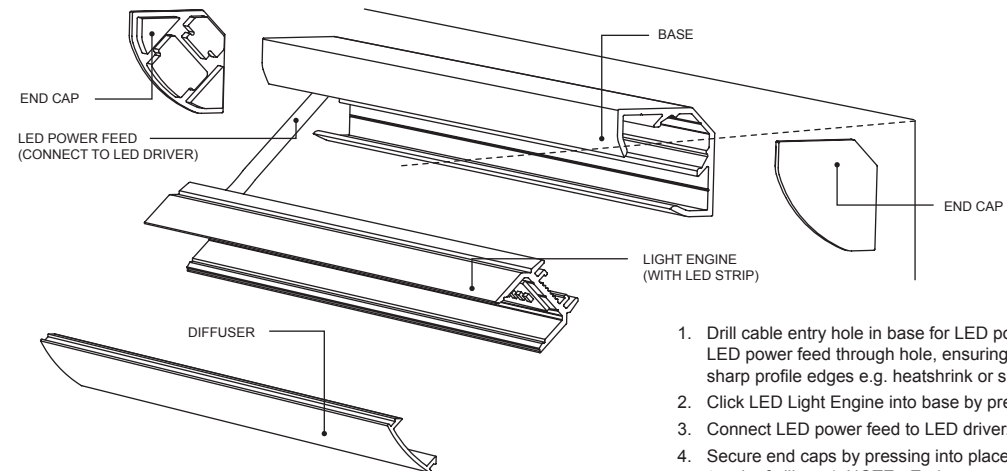

1. Drill cable entry hole in base for LED power feed. Thread LED power feed through hole, ensuring it is protected from sharp profile edges e.g. heatshrink or similar.
2. Click LED Light Engine into base by pressing firmly.
3. Connect LED power feed to LED driver.
4. Secure end caps by pressing into place (may require a touch of silicone). NOTE - End caps are required as part of the install for the TECHLINE range.