

SELF-COUNTERSINKING SCREW FIX

THESE FITTINGS ARE DESIGNED WITH SELF-COUNTERSINKING 

BASELINE 01 MINI V2

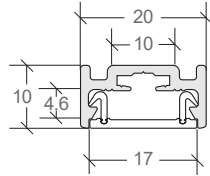

BASELINE 01 V2

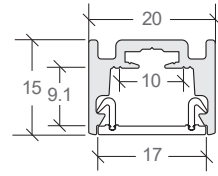
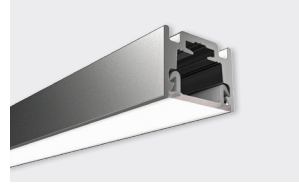

A. SELF-COUNTERSINKING PROFILE INSTALLATION

1. Drill preferred cable entry hole through base.
2. Where joining profile, use the appropriate joiner and tighten grub screws.
3. The self-countersinking design allows screws to cut out narrow aluminium wings as they are screwed in, leaving a flush surface for LED ribbon installation.

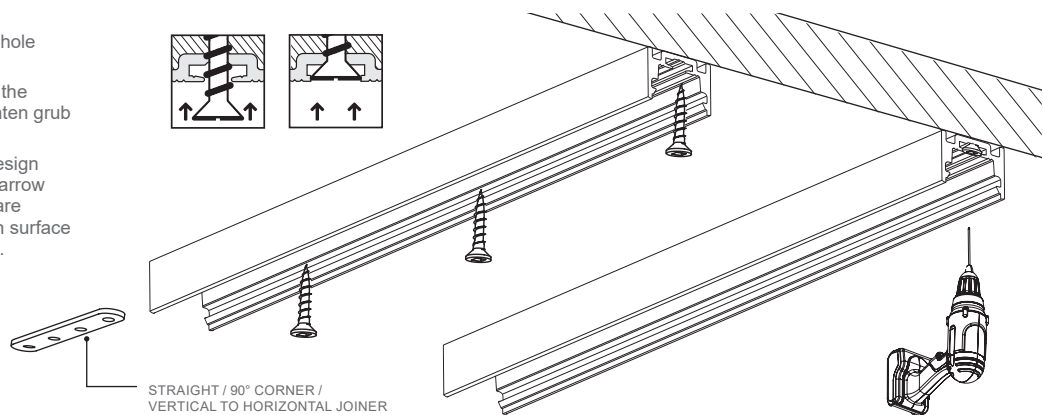

B. LED INSTALLATION

1. IMPORTANT - Before mounting LED strip, clean profile using an alcohol based cleaner.
2. Remove 3M paper from LED strip. Use the guide lines at the back of the profile as a guide to mount the LED strip.
3. Thread LED power feed through hole, ensuring it is protected from sharp profile edges e.g. heatshrink or similar.
4. Attach diffuser to profile by sliding or clicking in securely.
5. Secure end caps by pressing into place

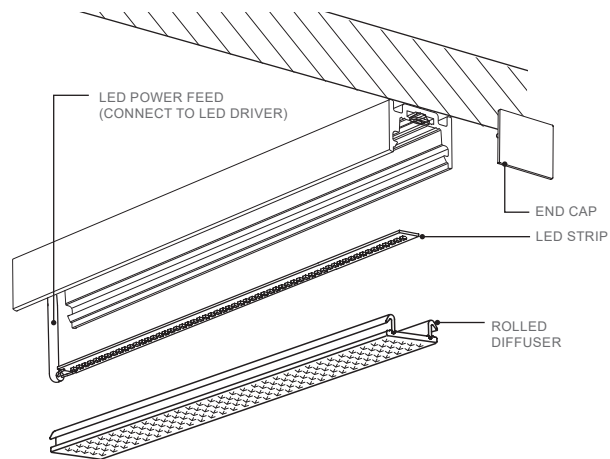

C. MAKE ELECTRICAL CONNECTION

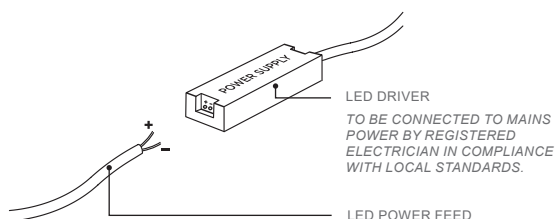

1. Connect LED power feed to LED driver.