

## NEON ARC DYNAMIC RGB 'CHASING' | WIRING GUIDE | SPI

TO AVOID SIGNAL FADING, ENSURE THE OVERALL CABLE LENGTH IS WITHIN THE MAXIMUM SIGNAL TRANSMISSION DISTANCE ACCORDING TO THE SPECIFICATION OF CONTROLLER/DECODER

- A compatible decoder or controller that outputs SPI signal is required for this product with UCS2903 or UCS2904 IC inside.
- The number of pixels light used should not exceed the maximum number of pixels of controller/decoder.
- Signal must always run in one direction, from 01 end to 02 end of light.

### SINGLE END FEED

#### STANDARD CONTROL

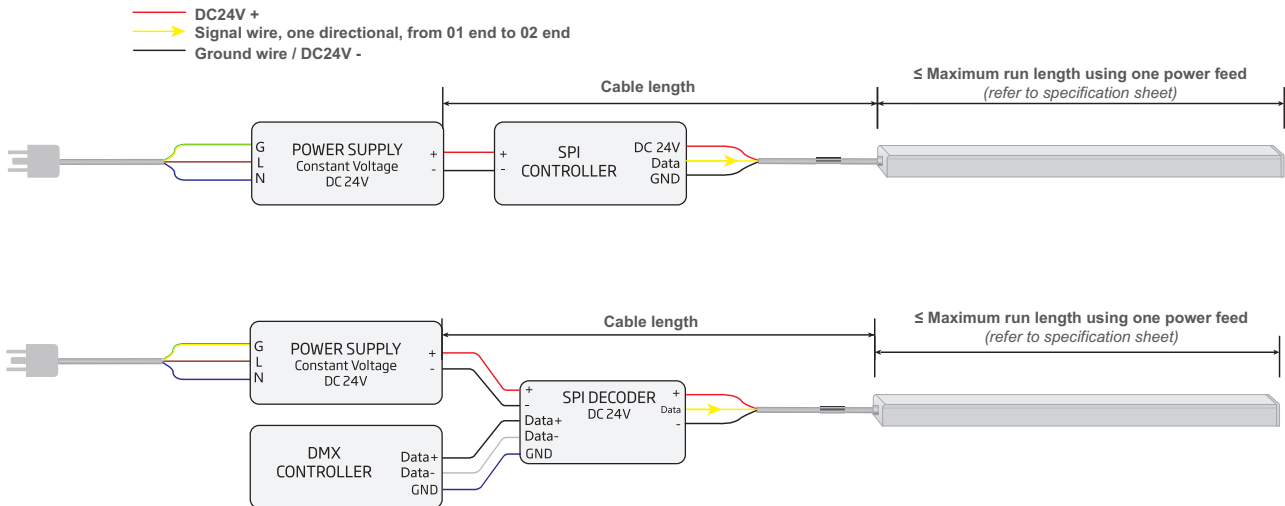

### DOUBLE END FEED

#### STANDARD CONTROL

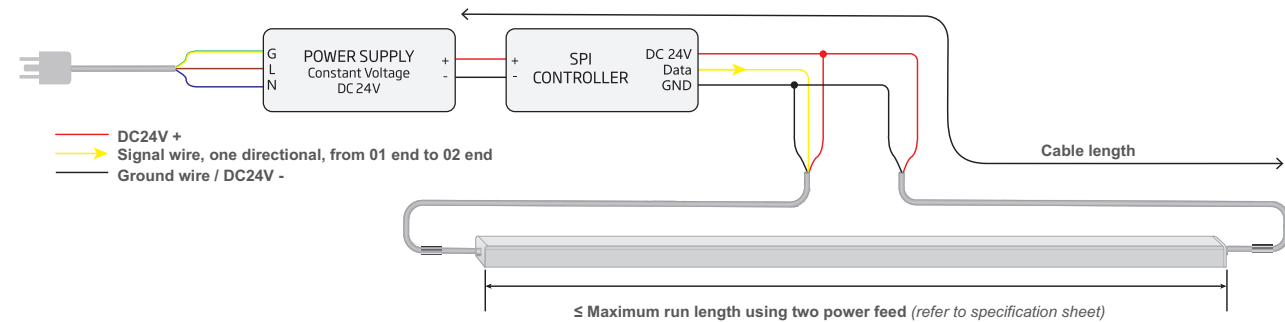

#### DMX CONTROLLER VIA SPI DECODER

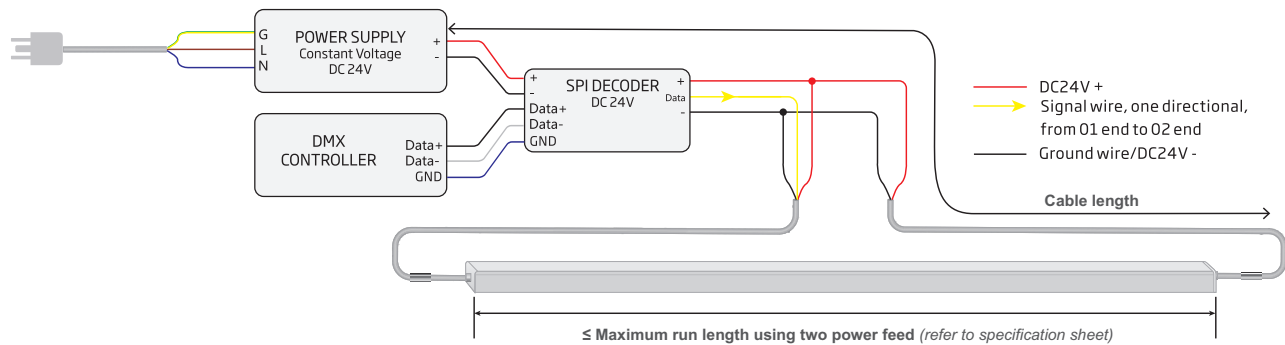

SEE PAGE 3 FOR CABLE LENGTH CHART

## NEON ARC DYNAMIC RGB 'CHASING' | WIRING GUIDE | SPI

TO AVOID SIGNAL FADING, ENSURE THE OVERALL CABLE LENGTH IS WITHIN THE MAXIMUM SIGNAL TRANSMISSION DISTANCE ACCORDING TO THE SPECIFICATION OF CONTROLLER/DECODER

### DOUBLE END FEED

### SPI CONTROL OF MULTIPLE LENGTHS

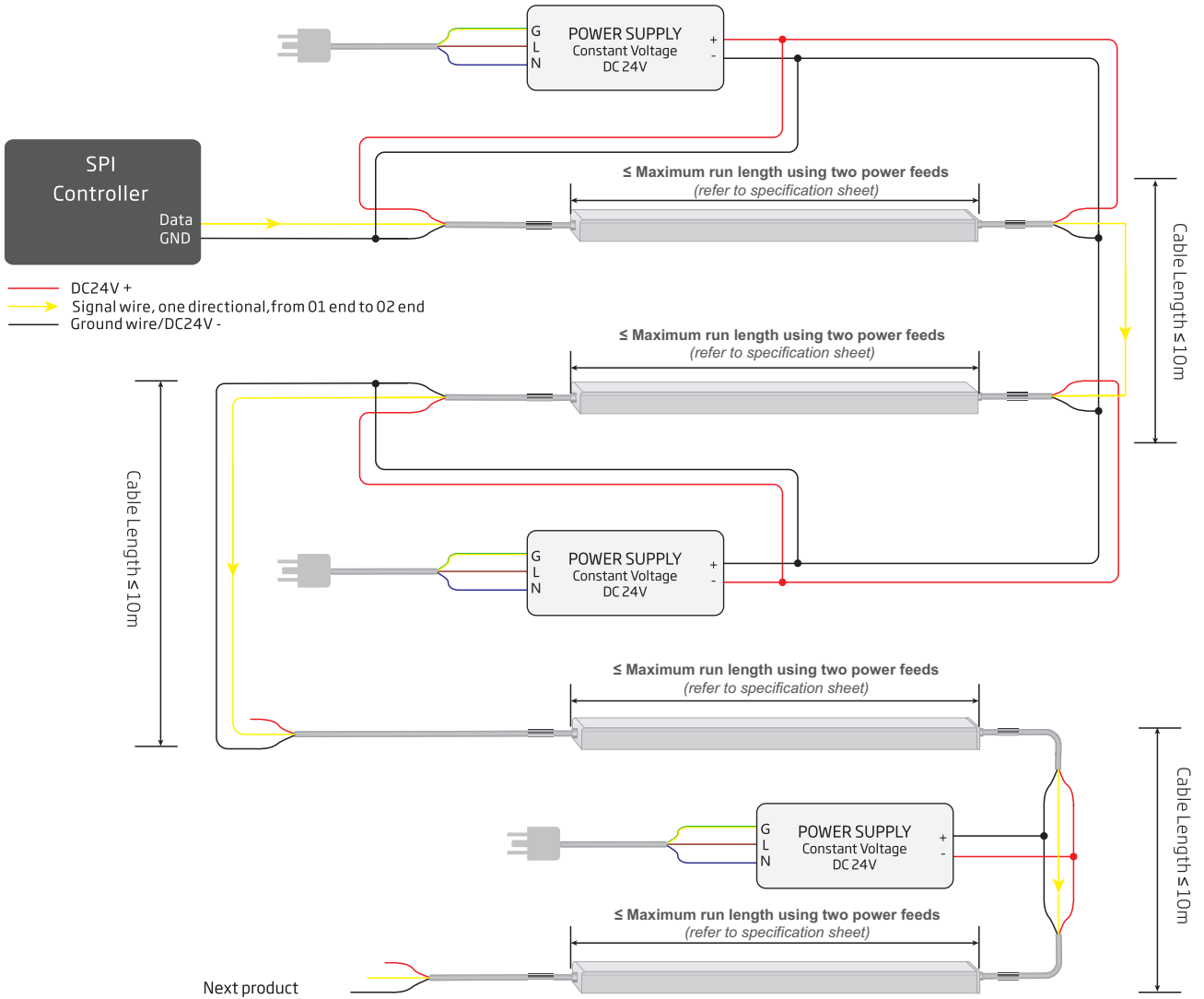

### 📖 READ ME

Ensure the polarity is correct on both ends! A short circuit might occur if powering the light from both ends with reverse polarity.

It is not recommended to feed both ends of light with two separated power supplies, to prevent resulting overloading and overheating if one power supply fails.

SEE PAGE 3 FOR CABLE LENGTH CHART

## NEON ARC DYNAMIC RGB 'CHASING' | POWER CABLE LENGTH

CABLE LENGTH = THE TOTAL LENGTH OF ELECTRICAL CABLE BETWEEN POWER OUTPUT END AND LIGHT INPUT END (INCLUDING ANY CABLES FOR INTERCONNECTION)

Refer to the chart where additional cable is required to access power on-site.

### SINGLE END POWER FEED

The chart shows the maximum cable lengths for different wire gauges for single power feed installation to avoid voltage drop.

### DOUBLE END POWER FEED

For a double power feed installation, look up half the light length for the cable length per feed (each side).

ie. For a 10metre light length you would look up a 5m light length on the chart (as each feed powers half the light).

Aim to position power supply in the middle of a single light (or multiple lights in daisy chain) to keep the same cable length for both ends.

LIGHT LENGTH (METRES)	MAX CABLE LENGTH SILICONE (METRES)				
	0.32mm <sup>2</sup> 22AWG	0.52mm <sup>2</sup> 20AWG	0.81mm <sup>2</sup> 18AWG	1.32mm <sup>2</sup> 16AWG	2.07mm <sup>2</sup> 14AWG
1	33.5	54.4	84.8	138.1	216.6
2	16.2	26.3	41.0	66.7	104.7
3	10.8	17.5	27.2	44.4	69.6
4	7.7	12.5	19.5	31.8	49.9
5	5.9	9.6	14.9	24.3	38.0
6		7.6	11.8	19.3	30.3
7		5.9	9.1	14.9	23.3
8	N/A	4.8	7.5	12.3	19.3
9			5.9	9.6	15.1
10			8.5	13.9	21.7

- LED Neon must always be used in conjunction with a certified Bright Light 24V DC power supply.
- Check the polarity of the connector before inserting the front connector and switching on the mains power.
- To minimise voltage drop and ensure consistent light output, position the power supply near to the power feed end of the LED Neon, and keep the line as short as possible

- Ensure your maximum run per power feed adheres to the guidelines; see specification sheet.
- Ensure to add 20% buffer when selecting a power supply
- Before making any cuts, installation, maintenance, or connection, be sure the mains power is disconnected.

- If essential; cut and connect LED Neon correctly. Any incorrect operation can cause damage.
- All connector joints must be connected correctly to achieve connector IP rating.

## IP67 MALE AND FEMALE CONNECTORS FOR PLUG AND PLAY CABLE JUNCTIONS

(CAN BE FITTED ONSITE OR SOLDERED TO THE LEAD WIRE OF NEON LIGHT AT FACTORY)

Additional, optional connectors which allow for plug and play type IP67 connections. Useful to connect to drivers, join two light lengths together, or for use where Neon may need to be removed occasional for maintenance etc.

ⓘ Connectors are matched to standard cable thickness for Neon product model, however there are different cable thickness options. Double check with max power cable length chart above to determine required cable choice and advise thickness.

