

METRO 50 TRACK LIGHTS



LED WATTS	CODE	SYSTEM WATTS	POWER FACTOR	FINISH	COLOUR	LUMENS	EFFICACY
38W	BL-CS-7100-WW	42W	≥0.98	White	Warm White 3000K	2700lm	64lm/W
	BL-CS-7100-NW				Natural White 4000K	2900lm	69lm/W
	BL-CS-7101-WW			Black	Warm White 3000K	2700lm	64lm/W
	BL-CS-7101-NW				Natural White 4000K	2900lm	69lm/W

IES FILES AVAILABLE

VOLTS	220–240V AC 50/60Hz input	CRI	90	DIMENSIONS	Base W76 × L160 × H37mm Light Ø90 × L205mm
OPERATING TEMP.	-20°C ~ +40°C	BEAM ANGLE	50° 18°, 25°, and 35° reflector accessories available	ADJUSTMENT	90° tilt 359° rotation
		SOURCE LIFE	50,000 hours	HOUSING	Die-cast aluminium
		LED BRAND	Citizen	BAFFLE	Black White available upon request
		WARRANTY	5 years	WEIGHT	1.63kg
		COMPLIANCE		INGRESS PROTECTION	Indoor use only
				CONNECTION METHOD	3-phase track connector
				CONTROL	Non-dimmable DALI options available

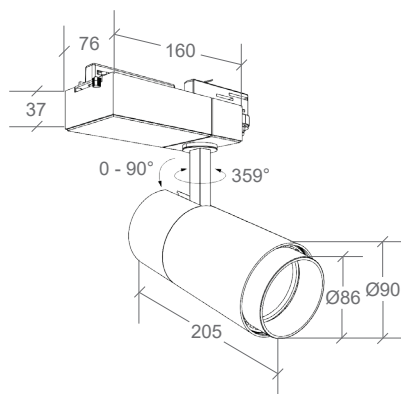

REFLECTORS

ACCESSORY	CODE
18° BEAM	BL-CS-71018
25° BEAM	BL-CS-71025
35° BEAM	BL-CS-71035

IES FILES AVAILABLE